

Volume 1

TURBO DIESEL Buyer's Guide



A Publication of the *Turbo Diesel Register*

TURBO DIESEL Buyer's Guide

A WORD ABOUT THE TURBO DIESEL BUYER'S GUIDE

Recently my wife and I spent much time looking for a “new” used car. I fired up my computer and downloaded archived articles from [Car and Driver](#) and [Automobile](#) and [Edmunds.com](#). There was a lot of superfluous information, free and for the taking. Honestly, the facts and figures just don't tell the complete story. You need data and experiences from other owners. I figure this sort of web search is pretty typical for prospective vehicle purchasers today.

As a writer it is tempting to tell the long story of “information being worth the price that you paid for it.” I will refrain. Many thought-provoking articles on the state of the publishing business versus the free-for-all of the interweb (pun intended) have been written and my opinion is not likely to change anyone's point of view.

Back to the subject at hand—you are a prospective or new owner. You want more information. You want it now.

Since the late 90s we have compiled information on the Dodge/Cummins Turbo Diesel truck. Each year we update the book. We call the data the [Turbo Diesel Buyers Guide](#), which you have successfully downloaded.

We're hopeful this book, and the opportunity to affiliate with other Turbo Diesel owners via the TDR will tip-the-scale in favor of a Ram truck.

Good luck. Let us know if we can help you.

Robert Patton
TDR Editor

This Buyer's Guide was last updated 9/2018.

TABLE OF CONTENTS

Why a Diesel?	4	Most Common Problems	308
Looking at the Changes, '94-'11	8	Favorite Fumbles—Fabulous Fixes	308
Evolution of the Cummins Engine, '89-'04	27	12-Valve Dowel Pin Common-Sensical Solution	313
'04-'07 HPCR Engine Changes	37	12-Valve No-Start Condition	317
The 6.7-Liter Engine Introduced	39	Vintage '94-'04 Lock/Unlock	318
Truck Ratings '89-'15	46	Mystery Switch	321
So You Want Fuel Economy	97	Block 53 and Class Action Settlement	323
Part One – The Basics of Volumetric Efficiency.	97	Steering Woes	326
Part Two – All Year Models and Updates	103	Fuel Transfer Pumps Revisited	337
Part Three – How to Drive	117	Fool Transfer Pump – '03 to Newer Trucks	356
Your Truck and the Boost Treadmill	121	Low Pressure Fuel System Problems	362
Buying a Used Truck	126	All About Exhaust Brakes – '89-'07 Trucks	366
What Does Every Turbo Diesel Owner		DTCs and You	371
Need to Know	128	Problems Solved by the TDR's Writers,	
The Driving Force Behind the Changes to the		TDR Members, and TDR Vendors	381
Cummins Engine/Meaningful Abbreviations	130	Mechanics Tips	389
Dodge Technical Service Bulletins	136	New Owner's Corner	392
TSBs Issued During '95 and Prior	137	Part Number Reference, '89-'12	393
TSBs Issued During '96	150	Why Ask Why—Liquids in Your Truck	395
TSBs Issued During '97	155	Memorable Articles	399
TSBs Issued During '98	159		
TSBs Issued During '99	163		
TSBs Issued During '00	169		
TSBs Issued During '01	174		
TSBs Issued During '02	177		
TSBs Issued During '03-'09	183		
TSBs and Recalls Issued During '97-'09	209		
TSBs and Recalls Issued During '10	214		
TSBs and Recalls Issued During '11	219		
TSBs and Recalls Issued During '12	226		
TSBs and Recalls Issued During '13	240		
TSBs and Recalls Issued During '14	252		
TSBs and Recalls Issued During '15	261		
TSBs and Recalls Issued During '16	273		
TSBs and Recalls Issued During '17	289		

A WORD ABOUT THE TURBO DIESEL REGISTER

How did the Turbo Diesel Register get its start? First off, I'm an automotive enthusiast. An automotive enthusiast that was in search of a tow vehicle for my admittedly small collection of automobiles. As you can imagine, the search for the right tow vehicle took me in the direction of the Ram/Cummins Turbo Diesel. My search was aided by the fact that my previous job was in the diesel engine profession as a Cummins distributor product support representative. Do I have a good knowledge of the Turbo Diesel engine? Well, maybe. I'll let you be the judge.

Back to the story. As an automotive enthusiast, I am a member of a handful of car club/register type publications. In addition, I subscribe to just about every car and truck monthly publication in hopes that I can learn something more about my vehicles. The only vehicle I owned that didn't have its own club was the Turbo Diesel. The light goes on. Why not start a Turbo Diesel club? The light flickers. I know the immediate answer: not enough time, no money, and who would write the articles? Needless to say, the idea got put on the back burner. Another great idea, but...

Looking back, that was 20+ years ago. Prior to our first magazine (Fall 1993) I took time to talk to other Turbo Diesel owners who wanted to know more about their truck and specifically the Cummins engine. At the time I knew the Turbo Diesel Register would work. I also knew it would be a lot of hard work with an up-front monetary investment and the commitment to publish the magazine.

Positive discussions with other club/register publishers and an unofficial "good luck" or two from the manufacturers, and well, I was still hesitant. Back to the all-important concerns: time, money and writing skills. Time? In the initial two-career-days it was nothing to stay up until 2:00 a.m. Money? What the heck, we took out a second mortgage. And writing skills? You've heard the saying, "if it is to be, it is up to me." Thus, we started the TDR way back in the summer of 1993.

Robert Patton TDR Editor

We hope you'll learn something from the following collection of tips and Dodge technical data. Please realize this Buyer's Guide is just the "tip of the iceberg." The TDR and its members provide a wealth of information. How to join? Please fill-out and mail the order form or register on-line at www.turbodieselregister.com.

Join Us Today!

An annual subscription to the Turbo Diesel Register is \$35.00 U.S. and \$45 Canadian/International.

Please complete this subscription form and enclose it in an envelope along with your check or money order payable to:

TURBO DIESEL REGISTER
1150 Samples Industrial Drive
Cumming, Georgia 30041

(770) 886-8877

Name _____

Address _____

City _____ State _____ Zip _____

Phone: Home () _____

Work () _____

Truck Year _____ Model _____

Payment Enclosed

Bill my Mastercard/VISA

_____ Exp. Date _____

WHY A DIESEL?

by Robert Patton

As the editor of a club news magazine (the *Turbo Diesel Register* for Dodge/Cummins owners), I am frequently asked, "Why is a diesel engine more fuel efficient than a gasoline engine of comparable displacement and horsepower?"

Let's see if I can provide a simple, no-nonsense answer. At the close of this article we'll do a quick diesel-payback example. Armed with a better understanding of why diesel provides a better payback on fuel consumption, you will be equipped to wring the most mileage from your tankful of diesel fuel.

How would you respond to, "Why is a diesel more fuel efficient?"

You may respond with one of the common clichés, such as, "It's the design of the diesel, it's built to be more efficient." How about, "The compression ratio is higher, there is more power?" Or, maybe a little more helpful, "The Btu content of diesel fuel is greater;" or perhaps, "It's in the injection system."

All of the above are correct, but the answers are pretty intuitively obvious.

When working with diesel powered generators, I encountered similar queries and responded with the same partial answers. I've seen the same "you didn't answer my question" body language from interested parties. It took being embarrassed in front of a large crowd before I vowed to get the complete answer.

Let's see if I can tie it all together and give you an answer you'll be able to use with your acquaintances. We will examine the diesel's design, compression ratios, fuel Btu's, and the fuel injection system to lead us to a concise answer, one that's easy to recall.

THE DIESEL'S DESIGN

"It's the design of the diesel; it's built to be more efficient."

The diesel engine was designed and patented in 1892 in Europe by Rudolf Diesel.¹ In the early part of the last century, Mr. Clessie Cummins, founder of Cummins Engine Company, refined the diesel design and developed engines to be used on-highway in the USA. Clessie's son, Clessie Lyle Cummins Jr., is a diesel historian. A passage from his book *Diesel's Engine* provides an historical perspective on Rudolf Diesel's early struggle to perfect his revolutionary engine and bring it to market.²

After a ten-year search Rudolf Diesel was convinced he had found the way to design an engine with the highest thermal efficiency. He believed the most difficult days were over and transforming ideas into reality should prove a simpler task: License a qualified manufacturer to develop and build the engine under his guidance and then await the forthcoming royalty check.

One company finally agreed to evaluate a test engine built to his design, but gave him no financial support. Because of this limited commitment he continued to promote his theories through the book based on his studies. Gift copies went to influential professors and companies deemed possible licensees. A few favorable academic endorsements resulted, but no new firms showed any interest. Meanwhile, when Diesel came to realize that his patented combustion process was unsuitable for a real engine he quietly substituted another. The path of his endeavors still failed to follow his optimistic, short range plan.

Diesel continued to seek the "highest thermal efficiency," or what he called a "heat engine," until his suicide in 1913. But the design principle is remarkably simple. From Mr. Clessie Cummins' book *My Days With the Diesel*,³ I'll let the senior Mr. Cummins explain.

As the term "heat engine" implies, the diesel differs in principle from the gasoline engine, in that [diesel] combustion is obtained by the heat created by compression of air in the cylinder. The diesel needs no electrical (spark) ignition system. Furthermore, it burns low-grade oil rather than the highly refined, more expensive fuels required by the gasoline engine.

Adjudged practical only for heavy-duty, stationary, or marine power applications, diesels, when I first encountered them, weighed as much as 400 pounds per horsepower and ran at very slow speeds. Entering the industry some eight years after introduction of the diesel in this country, I undertook a personal campaign, with the crudest of experimental facilities, to reduce this pound-per-horsepower ratio, despite all textbook rules to the contrary. These efforts culminated in the invention of the high-speed, light-weight automotive diesel.

For two decades, while struggling with the engine developments, I battled equally big odds to build a highly specialized business. Cummins Engine Company was incorporated in 1919, but it took the better part of eighteen years for our bookkeeper to need any black ink. Then success arrived with a rush, after the initially skeptical long distance truckers finally accepted our new engine.

Today Cummins Inc., of Columbus, Indiana, is the world's largest independent producer of automotive diesel engines. It provides jobs for ten thousand persons, with sales of more than \$250 million annually (the publish date of Clessie Cummins' book was 1967).

Note: 2005 sales were 9.92 billion.

Considering the level of technology in machined parts in the late 19th century, it is no wonder that Rudolf Diesel was unable to build his heat engine and prove its practicality. But in time, technology would catch up with the simplicity of Diesel's informing concept; and so the seemingly offhand answer that the design of the diesel is built to be more efficient is a true statement. Let's look further at the components that make the diesel different.

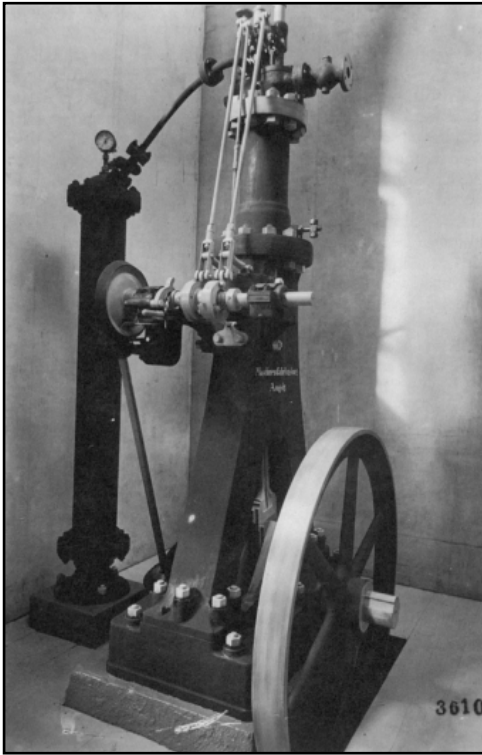

Diesel's first engine at the start of an 1893 test (photo courtesy of C. Lyle Cummins).

HIGHER COMPRESSION RATIO

"The compression ratio is higher, there is more power."

Technically speaking, the compression ratio of an engine is the comparison of the total volume of the cylinder at the bottom of the piston's stroke divided by the volume of the cylinder remaining at the top of the piston's stroke. Since we are familiar with gasoline engines, let's quickly discuss their compression ratios and a condition that spells disaster in a gasoline engine, detonation, or pinging.

The Gasoline Engine

Serious damage to a gasoline engine can result if you attempt to run a high compression ratio with low octane fuel. Detonation or pinging is the ignition of the fuel due to the high temperature caused by a high compression ratio/high pressure developed by a given design. Premature ignition of the fuel, i.e., coming before the spark of the spark plug, results in rapid uncontrolled burning. When timed properly, the approximate maximum compression ratio for a gasoline engine in race trim is 14:1. Most non-racing low octane compression ratios used in automobiles and trucks are less than 9:1.

The Diesel Engine

Remember, the diesel is a "heat engine" using heat energy developed from the compression of air. High compression ratios (ratios range from 14:1 to 20:1) are possible since air only is compressed. The hot compressed air is sufficient to ignite the diesel fuel when it is finally injected near the top of the compression stroke. A high compression ratio equals a greater expansion of the gases following ignition and a higher percent of the fuel's energy is converted into power! The diesel compression ratio is higher, there is more power! However, I've provided yet another incomplete answer that is a true statement, but not the complete story.

Thus far we've covered the principle of diesel operation and the high compression ratios needed to make the heat for diesel engine combustion. The high compression ratio requires the designers to test and manufacture the block, heads, head bolts, crankshaft, connecting rods, rod bolts, pistons, piston pins, etc., with greater structural capacity. Diesel engines are heavy in comparison to their gasoline brothers. Take, for example, the B-Series engine used in the Dodge pickup. It is 970 pounds for the 359 cubic inch Turbo Diesel engine versus 540 pounds for the 360 cubic inch Dodge Magnum V-8 gasoline engine. With the greater structure and a diesel's need for air, the turbocharger (introduced in the 1950s) was a natural fit for diesel engines.

Looking back, the first engine designed by Clessie Cummins in the 1920s was a monster at 400 pounds per horsepower produced. The year model 2005, 325 horsepower Cummins Turbo Diesel pickup truck engine is 3 pounds per unit of horsepower. I'd say diesels have made some progress in 85 years.

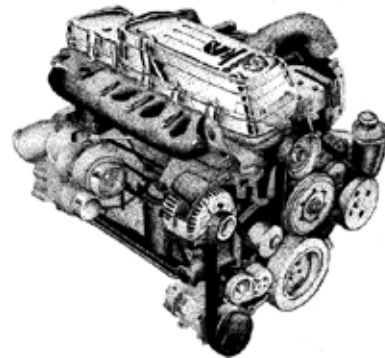

The Cummins engine used in today's Dodge pickup.

FUEL BTU'S

"The BTU value of diesel is greater."

Quite true, the BTU, or British Thermal Unit, for diesel fuel is 130,000 per gallon, with a weight of 7.0 lbs./gallon. The value for gasoline is 117,000 BTUs at a weight of 6.3 lbs./gallon. If we go back to our basic physics rules for energy, you'll note the fuel in the tank has potential for work if it is injected into the cylinders and, when combined with the compressed heated air, ignited. The piston is forced downward, the crankshaft rotates, and the wheels turn. True as all this is, the BTU value is not the major contributing factor to the diesel's miles-per-gallon superiority. So, what is the key answer?

THE INJECTION SYSTEM

"It's in the injection system."

Rudolf Diesel designed the heat engine to use the injection of fuel at the last moment to ignite the compressed air. Understanding the heart of the diesel, the fuel pump, is the key to answering the fuel efficiency question.

The Gasoline Engine

A gasoline engine is what engineers call "stoichiometric." Stoichiometric describes the quantitative relationship between two or more substances, especially in processes involving physical or chemical change. With a gasoline engine there is a stoichiometric equation of 14 parts of air to one part of fuel. Remember, *always* 14:1. Whether at idle or full throttle, the fuel and air are mixed *outside* the cylinders in a carburetor or injection manifold, and the mixture is introduced to the combustion chamber via the intake valve, 14:1, *always*.

The Diesel Engine

Fuel and air in the diesel design are not premixed outside the cylinder. Air is taken into the cylinder through the intake valve and compressed to make heat. Diesel fuel is injected near the top of the piston's stroke in an amount or ratio corresponding to the load on the engine. At idle the air-to-fuel ratio can be as high as 85:1 or 100:1. At full load the diesel still boasts a miserly 25:1 or 30:1 ratio! It *is* in the injection system where we find the key to the diesel's fuel mileage superiority.

The Fuel Pump is the Key

The fuel pump used on early '90s vintage diesel pickup trucks typically was a rotary style fuel pump. Think of this pump as a mini automobile-spark-distributor. A rotary head sends fuel pulses through the high-pressure fuel lines to the injectors. The pressure opens the injector valve, and fuel is injected.

As exhaust emissions standards tightened in 1994, there was a need for higher fuel injection pressures and more timely delivery of fuel into the combustion chamber. Pickup truck leader, Ford, used an injection system developed by Caterpillar called HEUI (hydraulically-actuated, electronically controlled, unit injection). The Dodge/Cummins engine used a Bosch P7100 in-line fuel pump. Think of it as a mini in-line six cylinder engine, and it's easy to understand its principle of operation. Six plunger pumps actuated by the pump camshaft send fuel pulses through six high pressure fuel lines to the injectors. The pressure opens the injector valve, allowing fuel to pass into the combustion chamber. With the Bosch P7100 fuel pump the metering of the fuel (at idle, 85:1; or at full load, 25:1) is controlled by a fuel rack and gears that rotate a metering helix to allow fuel into the six plunger pumps.



C. Lyle Cummins Jr. poses in front of a '02 Dodge/Cummins Turbo Diesel pickup.

FUTURE CONSIDERATIONS

Further exhaust emission legislation in 1998 and again in 2002 has forced the diesel engine manufacturers to introduce electronic fuel injection controls. Key legislation dates were 1988, 1994, 1998, and 2002. Thus the progression from simple mechanical (vintage 1988-1993) to more complex mechanical (vintage 1994-1997) followed by simple electronics (vintage 1998-2001) and now advanced electronics (2002 and newer) has been the norm that the diesel industry has followed. Stay tuned as the 2007 emissions legislation has brought another dramatic decrease in exhaust emissions for diesel engines in pickups and big-rigs.

1. We capitalize "Wankel" when referring to a rotary engine. When did we stop capitalizing the "D" in diesel?
2. I found Lyle Cummins' *Diesel's Engine* to be a complete history of Rudolf Diesel's engineering efforts. For information on how to order this book, please see this story's source table. I'll bet that if you request it, Mr. Cummins will autograph your copy! A must for your automotive library.
3. The senior Cummins' book, *My Days with the Diesel* is no longer in print (publication date, 1967). Lyle Cummins remembers his father in his recent book, *The Diesel Odyssey of Clessie Cummins*. Copies of the latter book are available. Again, please see the source table for complete information.

Sources:

Diesel's Engine (760 pages, \$55) and *The Diesel Odyssey of Clessie Cummins* (400 pages, \$37) are books written by diesel historian Clessie Lyle Cummins Jr. Published by Carnot Press. The books can be ordered at (503) 694-5353.

DIESEL VERSUS GASOLINE DO THE MATH

My own experience has been with a 2002 Dodge 1500 with its 360 cubic inch (5.9 liter) gasoline engine and a 2003 Dodge 2500 with the 359 cubic inch (5.9 liter) Cummins diesel engine. Overall numbers in around-town driving equated to 13.5 mpg gasoline, 18.5 diesel.

In our example, let's figure that I travel 20,000 miles per year.

$$\text{Gasoline usage: } \frac{20,000}{13.5} = 1,481 \text{ gallons used}$$

$$\text{Diesel usage: } \frac{20,000}{18.5} = 1,081 \text{ gallons used}$$

It used to be that the price of diesel fuel was less than that of regular gasoline. Lately in my area that has not been the case. However, for comparison sake, let's assume the numbers are equal at \$3 a gallon.

$$\text{Gasoline expense: } \$3 \times 1,481 = \$4,443$$

$$\text{Diesel expense: } \$3 \times 1,081 = \$3,243$$

$$\text{Diesel net yearly fuel savings} = \$1200$$

Estimated sticker price for the optional diesel engine – \$7,000

Years (assuming 20K per year) and miles to payback – 5.8 years or 116,000 miles

If you subscribe to the adage, "Figures don't lie, but liars figure," you can easily make the previous example work for a shorter or longer payback period. In this short, down-n-dirty comparison we're not going to consider maintenance or resale values. And don't lose track of the obvious: as the diesel engine option in pickup trucks continues to price-creep upward, the payback is longer; however, as fuel prices rise, the payback is quicker.

To close the do-the-math example, remember that "your mileage may vary based on driving conditions." Don't ya love the clichés of automotive doubletalk?

Robert Patton
TDR Staff

LOOKING AT THE CHANGES - A TURBO DIESEL BUYER'S GUIDE

by Jim Anderson

Aside from the quarterly column and articles that I write for the TDR, I also serve as the "e-mail and call-back" guy. Yep, that means I get lots of correspondence from those interested in the TDR as well as those interested in the purchase of a truck. With the ever-changing ownership of vehicles, the idea of a Turbo Diesel Buyer's Guide makes perfect sense. To that end, the editor asked me to do a study of changes by model year to Dodge/Cummins trucks.

Since its 1994 introduction, the current body style Dodge Ram pickup has undergone many changes and modifications.

To properly compile such a list, changes for each model year seem to build on each preceding model year, and therefore you may want to read from the start (1994) to see total changes and cumulative modifications for the particular model year you wish to research.

Each model year after 1994 contains changes in the form of additions and deletions to the previous model(s). Only major changes and major new options are covered. As you know, each year contains changes to paint colors and schemes, and interior upholstery colors and materials. These are not outlined in our research. Likewise, many minor technical adjustments and changes such as a change in tailgate hinge pin diameter are not listed, as they don't really affect the overall performance of a given model.

Changes and modifications covered will only be for those truck models (2500 and 3500 pickup and cab/chassis models) which were offered with the Cummins Turbo Diesel engine option package.

Sharp-eyed owners may pick up discrepancies and/or errors of omission. These errors are solely the responsibility of your columnist who was assigned this daunting task. I went with the information provided by Dodge's data books, which are written at the beginning of a model year and do not reflect later "running" production changes.

Overview

Warranty began in 1994 with a basic one year 12,000 mile warranty on the entire truck, and 5 year/ 70,000 mile powertrain warranty. The separate truck/powertrain warranties were consolidated and currently the package is 3 years/36,000 miles on the entire truck, including powertrain. Engine warranty has stayed constant at 5 years/100,000 miles.

Tow Ratings have changed considerably from year to year and from option model to option model, and even within option models, so read carefully if you are interested in or seeking such information. Some models were/are rated to tow much less weight than others. Watch out for "lightweights"!

Problem Areas: Please keep in mind that there is no such thing as the perfect truck or car. All vehicles will contain certain designs, systems, or parts that are more prone to failure than might normally be expected. Looking at these negatives, the image of the vehicle can be tarnished. However, to look on the positive side, the owner is aware of the problems and can take corrective action and make informed decisions. With these thoughts in mind, the following are common problem areas on the subject trucks.

Common Problem Areas 1994-1998.5: Included failed engine start/run solenoids; frayed throttle cables; hard start due to degradation of the rubber fuel return line; automatic transmissions problems that were often caused by fluid loss at transmission line-to-cooler, line-to-transmission, quick couple plastic fittings; poor fuel filter access; loss of fifth gear in five-speed transmissions; failed front end parts on 4x4 models; poor front brake pad life in certain applications; poor paint adhesion of certain colors; failure of throttle position sensors on automatic trucks; and faulty fuel level sending units.

Common Problem Areas 1998.5 to 2002: Included failed fuel transfer pumps and fuel injection pumps; weak clutch on six-speed trucks; poor front brake pad life in certain applications; and poor front suspension bushing life on 4x4 models.

FROM THE DATA BOOKS

The following information was compiled using DaimlerChrysler data books. Actual production may be slightly different, especially if a particular truck was produced near the beginning or end of a particular model year run.

We will start with the 1994 model, which is the first year of the current body style. For each model year we will note what's new, models available, engine ratings, transmissions, maximum tow ratings, cab/chassis models, and comments.



This interesting photo is an early '94 model truck that was modified to run at Bonneville. It successfully set a class record at the 1997 Bonneville Speed Weeks of 141.256 mph. (TDR Issue 15, page 44).

SECOND GENERATION

1994 TURBO DIESEL

What is New: Introduction of the current truck platform. Everything is new.

Models Offered: 2500 and 3500, two-wheel drive, four-wheel drive, Standard Cab, long bed only.

Cab: Rather revolutionary styling, which has since been emulated by other truck manufacturers. Styling changes included protruding grille and hood. Grille is attached to hood and raises with hood for improved underhood access. Cab has aerodynamically correct shape.

Offered only as a Standard Cab, long bed truck, and as a cab-chassis model. Two trim levels; ST in vinyl and SLT in cloth. Cab features include redesigned dash with full gauges featuring numbered graduations. All major cab controls designed to be operated by a gloved hand. An optional bench seat with a 40-20-40 center console split is offered with the center console capable of containing a laptop computer and cellular phone. Cab is attached to frame using resilient rubber donut cushions. Large sloped tinted windshield with parallel wipers, driver side air bag, open storage nook in right side of dash for future addition of passenger side air bag, cruise control buttons on steering wheel, and reclining driver seat.

Chassis: All new frames with combinations of boxed and "C" channeled sections for greater rigidity. Front suspension consists of independent coil springs with 4500 pound capacity front axles on 16" tires. Rear suspension is 60" long semi-elliptic leaf springs on a rigid axle of varying capacity ratings by model for improved ride quality. Two axle ratios are offered: 3.54 and 4.10:1. Three rear axles are offered: Dana 70 for 2500 automatics, hybrid Dana 80 for 2500 manual, and Dana 80 for 3500 trucks and cab-chassis trucks. The long tapered rear springs offer a smoother, less choppy ride over rough roads. The truck bed is rigidly mounted to the frame, and is only offered as a sweptsided design 8 foot box. The bed also features indents in the bed to allow building a framework to carry multi-tiered loads. Bed tiedown mounts are standard front and rear. The tailgate is detachable.

Engine Ratings: The Cummins B 5.9 diesel was offered in two horsepower/torque ratings: 175HP/420 ft-lbs torque for manual transmissions, and 160/400 for automatic transmissions. New is an inline Bosch fuel injection pump (designated P7100). Intake air plumbing has been re-designed for greater airflow. The turbocharger is a wastegated design.

Effective 1/1/94 the truck's were equipped with a catalytic converter to try and address the particulate matter that is associated with diesel exhaust. The catalytic converter would be used on these trucks until the introduction of the 24-valve engine, effective 1/1/98.

Transmissions:

- Five-speed manual NV4500HD: 5th overdrive. 450 ft-lbs input torque capacity.
- Four-speed automatic 47RH: 4th overdrive with locking converter. 380 ft-lbs torque capacity.

Looking Back: Being an all-new model, this truck had a number of teething problems which resulted in both federal safety recalls and factory TSB fixes. Chief among recalls was a fix for keys sticking in the backside of the steering wheel, causing the wheel to jam; recalls for various covers to be installed on steering shaft linkages, and headlight switches burning out.

Major owner gripes centered around poor fuel filter and oil filter access, moisture intrusion and retention into cab and cab doors, vision obstruction by the A-pillars, poor adhesion of certain colors of paint, failure of the OEM Goodyear tires to maintain their balance, loss of fifth gear in the manual transmissions, fraying of the unsheathed throttle cable.

Conclusions: These trucks have proven to be very durable, though not particularly good looking after several years of use. Owners have reported driving them in excess of one million miles without *any* major internal engine work.

1995 TURBO DIESEL

What is New:

- Extended Cab.
- Revised paint schemes and colors.

Models Available:

- 2500HD as Standard Cab, Extended Cab, long bed, 4x2 and 4x4.
- 3500: same as above.

Engine Ratings:

- Same as 1994 model year.
- 175 HP and 420 ft-lbs for manual transmission.
- 160 HP and 400 ft-lbs for automatic transmission.

Transmissions:

- No changes from 1994.
- Five-speed manual 4500HD 5th overdrive.
- Four-speed automatic 47RH 4th overdrive with locking converter.

Maximum Tow Ratings:

- 2500 and 3500:
- 3.54 Axle, maximum GCWR is 14,100 pounds.
- 4.10 Axle, maximum GCWR is 16,000 pounds.

Cab/Chassis Models:

- None.

Comments:

The '95 model is largely a carryover from the '94 model year with the exception of the introduction of the Extended Cab.

1996 TURBO DIESEL

What is New:

- Deleted tailgate top protector.
- Deleted SLT tape stripe.
- Added optional Camper suspension package.
- Revised optional radio.
- Revised alternator rating to 136 amps.
- Revised "RE" electronic control of automatic transmission.

Models Available:

- 2500HD as Standard Cab, Extended Cab, long bed, cab chassis, 4x2, and 4x4.
- 3500: same as above. No short bed models available.

Engine Ratings:

- Increased for 1996
 - 215 HP and 440 ft-lbs for manual transmission.
 - 180 HP and 420 ft-lbs for automatic transmission.
- California engines were rated lower at 1995 specs. At mid-year 1996 California engines were required to have exhaust gas recirculation (EGR).

Transmissions:

- Five-speed manual NV4500: 5th overdrive.
- Four-speed automatic 47RE: 4th overdrive with locking converter. This is a new electronically controlled transmission.

Maximum Tow Ratings:

- 2500 Regular Cab, manual or automatic, 3.54 axle: 10,500 pounds; 16,000 GCWR.
- 2500 Regular Cab, manual or automatic, 4.10 axle: 12,300 pounds; 18,000 GCWR.
- Derate trailer weight for 4x4: 3.54 axle -500 pounds; 4.10 axle -400 pounds.
- Derate trailer weight for Extended Cab: -0
- 3500 Regular Cab, manual or automatic, 3.54 axle: 10,500 pounds, 16,000 GCWR.
- 3500 Regular Cab, manual or automatic, 4.10 axle: 11,900 pounds, 18,000 GCWR.
- Derate trailer weight for 4x4: 3.54 axle ratio - 800 pounds; 4.10 axle -400 pounds.
- Derate trailer weight for Extended Cab: 3.54 ratio -800; 4.10 ratio -400 pounds.

Cab/Chassis models:

- Available in Regular Cab only. 2500 is 8,800 GVWR, 56" C/A (cab rear to rear axle centerline) dimension. 3500 is 11,000 GVWR and available in 60" and 84" C/A dimensions.

Comments:

Trailer tow ratings begin to get confusing. Performance complaints stem from computer programming of new electronically controlled automatic transmission. Exhaust Gas Recirculation added to California trucks (1/1/96) to meet CARB emissions standards. Owners begin to find out how easy and inexpensive it is to "turn up the power."

1997 TURBO DIESEL

What is New:

- Hydraulic power brake booster powered from power steering pump.
- Increased weight capacity to 11,000 GVW on club cab 3500 models.
- Remote keyless/ illuminated entry option.
- New AM/FM/Cassette/CD player option.
- Leather interior group option.

Models Available:

- 2500HD as Standard Cab, Extended Cab, long bed, cab chassis, 4x2 and 4x4. Combo of short box Extended Cab diesel not offered.
- 3500: Same as above. No short bed models available.

Engine Ratings:

- Same as 1996 model year.
 - 215 HP and 440 ft-lbs for manual transmission.
 - 180 HP and 420 ft-lbs for automatic transmission.
- California engines continue with EGR but are offered with 180 HP and 420 ft-lbs of torque in both automatic and manual transmission applications.

Transmissions:

- No changes from 1996.
- Five-speed manual NV4500HD, 5th overdrive.
- Four-speed automatic 47RE 4th overdrive with locking converter.

Maximum Tow Ratings:

- 2500 manual 4x2 regular and Extended Cabs: 20,000 GCWR. 2500 automatic 4x2 regular and Extended Cab: 3.54 axle, 16,000 GCWR; 4.10 axle, 18,000 GCWR.
- 2500 manual and automatic 4x4 regular and club cabs: 3.54 axle 16,000 GCWR; 4.10 axle 18,000 GCWR.
- 3500 manual 4x2 regular and Extended Cabs: 20,000 GCWR. 3500 automatic 4x2 regular and Extended Cab: 3.54 axle 16,000 GCWR; 4.10 axle 18,000 GCWR.
- 3500 manual 4x4 regular and Extended Cabs: 3.54 axle 16,000 GCWR, 4.10 axle 18,000 GCWR.
- 3500 automatic 4x4 regular and Extended Cabs: Regular Cab, same as above. Extended Cab, 4.10 axle only, 18,000 GCWR. 3.54 ratio not available with Extended Cab automatic option.

Cab/Chassis models:

- Available in Regular Cab only. 2500 is 8,800 GVWR, 56" C/A (cab to axle) dimension. 3500 is 11,000 GVWR and available in 60" and 84" C/A dimensions. New options include rear helper spring and stabilizer bar group, 9.24 section modulus frame, snowplow prep group with some engine/transmission combos.

Comments: California trucks have exhaust gas recirculation and net horsepower is lower. Last full year of the 12-valve engine production.

1998 TURBO DIESEL

What is New:

- Quad Cab option featuring doors on each side of Extended Cab with no "B" pillar.
- Front seat belts integrated into seats on all Extended Cab and Quad Cab trucks.
- New interior with redesigned dash. Dash is electronic on '98.5 models.
- 2500 short box Extended Cab and Quad Cab model with diesel is available.
- Passenger side airbag with disable switch is standard.
- Next generation airbags.
- Heated power mirrors.
- Illuminated door lock and power window switches.
- Optional security alarm system.
- Revised fifth gear nut on five-speed manual transmission.

1998.5 Update:

- 24-valve electronic controlled injection diesel offered as a '98.5 model.

Models Available:

- 2500HD: as Standard Cab, Extended Cab, Quad Cab, short bed, long bed, cab chassis, 4x2 and 4x4.
- 3500: Same as above. No short bed models available.

Engine Ratings:

- 12-valve head, mechanical injection pump.
- 215 HP and 440 ft-lbs for manual transmission except California.
- 180 HP and 420 ft-lbs for automatic transmission and California manual transmission. California engines continue with EGR.

Note: A '98.5 engine was introduced (1/1/98) to meet more stringent emissions standards. Known by the Turbo Diesel audience as the 24-valve. It included electronic control of fuel injection and a 24-valve cylinder head. Rated at 235HP and 460 ft-lbs of torque for manual applications and 215/420 for automatic transmissions. No rating difference for California, as the 98.5 engine was 50-state certified without EGR and without a catalytic converter.

Transmissions:

- No changes from 1996.
- Five-speed manual NV4500HD: 5th overdrive.
- Four-speed automatic: 47RE 4th overdrive with locking converter.

Maximum Tow Ratings:

- 2500 Regular Cab, Extended Cab, Quad Cab, manual, 4x2, 3.54 or 4.10 axle 20,000 GCWR. Except 12-valve California trucks, 3.54 axle is 16,000, 4.10 axle is 18,000 GCWR.
- 2500 Regular Cab, Extended Cab, Quad Cab, automatic 4x2 and all 4x4 models; 3.54 axle 16,000 GVWR, 4.10 axle 18,000 GVWR.
- 3500 Regular Cab, manual, 4x2, 3.54 or 4.10 axle is 20,000 GVWR.

- 3500 Extended Cab, Quad Cab, manual, 4x2 and 4x4; 3.54 axle 16,000 GCWR, 4.10 axle 18,000 GCWR.
- 3500 Extended Cab, Quad Cab, automatic, 4x2 and 4x4, 3.54 axle 16,000 GCWR, 4.10 axle 18,000 GCWR.

Cab/Chassis models:

- Available in Regular Cab only. 2500 is 8,800 GVWR, 56" C/A (cab to axle) dimension. 3500 is 11,000 GVWR and available in 60" and 84" C/A dimensions.
- 2500 and 3500 manual have 20,000 pound tow rating with either axle in 4x2 and 4x4.
- 2500 and 3500 automatic 4x2 and 4x4 have 16,000 GCWR with 3.54 axle and 18,000 GCWR with 4.10 axle.

Comments:

Watch tow ratings carefully! Mid-year introduction of the 24-valve engine for cleaner emissions. Early problems with failed fuel lift pumps and locked up injection pumps. Owners find out that a 4.10:1 axle ratio is better for towing with the 24-valve engine, since the power band has been moved higher in the RPM range. 24-valve engine governed RPM is raised to 3,200. Electronically controlled fuel injection produces a flat torque curve from 1700-2700 RPM. In November of '98, Dodge issues a bulletin to all dealers informing them that exhaust brakes are not approved for use with automatic transmission-equipped trucks (Issue 24, page 38).

1999 TURBO DIESEL

What is New:

- Deleted Extended Cab option in middle of model year.
- Deleted side body trim from aft of rear wheels.
- Electronic dash with all gauges run by computers.

Models Available:

- 2500HD as Standard Cab, Extended Cab, Quad Cab, short bed, long bed, cab chassis, 4x2 and 4x4.
- 3500 same as above, except no short beds.

Engine Ratings:

- Same as '98.5 model year.
- 24-Valve electronic injection control 235HP 460 ft-lbs torque for manual transmissions.
- 24-Valve electronic injection control 215HP 420 ft-lbs torque for automatic transmission.
- Peak torque available from 1700-2700 RPM.

Transmissions:

- Five-speed manual NV4500HD: 5th overdrive.
- Four-speed automatic 47RE: 4th overdrive with locking converter.
- Six-speed manual NV5600: 6th overdrive – late availability and soon withdrawn from sale.

Maximum Tow Ratings:

- All configurations and axle ratios of manual transmission trucks: 20,000 GCWR.
- All configurations of automatic transmission trucks: 3.54 axle 16,000 GCWR, 4.10 axle 18,000 GCWR.

Note: Maximum permissible trailer weight will vary by model

and options. For example, 4x4 models are rated for lower maximum trailer weights than 4x2 models, and extended/Quad Cab models are rated for lower maximum trailer weights than Standard Cab models. Highest trailer weight rating is for a 2500 Regular Cab 4x2 manual transmission long bed = 14,150 pounds trailer.

- Lowest trailer weight rating is for a 3500 Quad Cab 4x4 automatic transmission 3.54 axle = 9,050 pounds trailer.

Cab/Chassis Models:

- Available in Regular Cab only. 2500 is 8,800 GVWR, 56" C/A dimension. 3500 is 11,000 GVWR and available in 60" and 84" C/A dimensions. Tow ratings are same as above.

Comments:

- Six-speed transmission removed from sale due to quality control issues.
- Users find the 4.10 axle ratio is best for towing with the 24-valve engine.

2000 TURBO DIESEL

What is New:

- Optional fold away towing mirrors.
- Optional automatic dimming rear view mirror.
- Revised front disc brakes with two piston calipers.
- 4 wheel anti-lock brakes standard on 3500 series trucks.
- Added radio with CD changer controls. Changer is a dealer installed Mopar accessory.
- Deleted body side moldings from entire bed sides.
- Deleted Extended Cab option, leaving only the Quad Cab option.
- Anti-spin rear axle only available in 4.10 ratio.
- Optional 265/75R/16E Michelins on 7.5 x 16" cast aluminum wheels for all 2500 models.
- 3500 series standard tires are now LT235/85R/16E using steel wheels of greater offset.

Models Available:

- 2500HD as Standard Cab, Quad Cab, short bed, long bed, Cab/Chassis, 4x2 and 4x4.
- 3500: Same as above. No short bed models available.

Engine Ratings:

- Same as '98.5/'99 model years.
 - 235HP 460 ft-lbs torque for manual transmissions.
 - 215 HP 420 ft-lbs torque for automatic transmissions.

Transmissions:

- Five-speed manual NV4500HD: 5th overdrive.
- Six-speed manual NV5600: 6th overdrive.
- Four-speed automatic 47RE: 4th overdrive with locking converter.
- The six-speed manual transmission has the same first and overdrive ratios as the five-speed, with an additional ratio interposed between second and fourth gears. Fifth gear is direct.

Maximum Tow Ratings:

- 2500 Regular Cab and Quad Cab, 4x2, both manual transmissions, both axle ratios 20,000 GCWR.
- 2500 Regular Cab and Quad Cab, 4x4, both manual transmissions, both axle ratios 20,000 GCWR with the exception of the Quad Cab 4x4 short bed 3.54 axle=16,000

GCWR; 4.10 axle=18,000 GCWR.

- 2500 Regular Cab and Quad Cab, 4x2 and 4x4, automatic; 3.54 axle=16,000 GCWR, 4.10 axle= 18,000 GCWR.
- 3500 Regular Cab and Quad Cab, 4x2 and 4x4, long bed, both manual transmissions, both axle ratios, 20,000 GCWR.
- All 3500 automatics: 3.54 axle=16,000 GCWR, 4.10 axle=18,000 GCWR.

Cab/Chassis Models:

Available in Regular Cab only. 2500 is 8,800 GVWR, 56" C/A (cab to axle) dimension. 3500 is 11,000 GVWR and available in 60" and 84" C/A dimensions. GCWR is same as tow ratings above.

Comments:

The 2000 model year Dodge truck was a production run of only three months. Effective on 1-1-2000, Dodge introduced their trucks as 2001 models. Coinciding with the 2001 pickups, Dodge introduced the 2001 PT Cruiser. For corporate average fuel economy (CAFE) criteria, the PT Cruiser is classified as a truck. We speculate the long model run of 2001 truck goes hand in hand with the higher mileage PT Cruiser, thus giving Dodge an edge in the CAFE numbers.

The six speed manual transmission remained on back order all year due to high demand.



Kelly Reed



Phil Putnam

Examples of '94-'02 Second Generation trucks. (TDR Member Archives)

2001 TURBO DIESEL

also 2001.5 models

What is New:

- New "Sport" and "Off Road" badges.
- Added child seat top tether anchors on Quad Cab rear seat.
- Four-wheel disc brakes are standard with vented rotors in rear, integral drum parking brake as a 2001.5 model.
- Four-wheel ABS standard, with new dynamic rear proportioning braking system as a 2001.5 model.
- Servoless speed control for manual transmission diesels.
- Forged aluminum wheel option on 2500 trucks.
- One touch drivers side power window down feature on SLT and + packages.
- New engine ratings of 235 HP/460 ft-lbs for both five-speed and automatic transmissions.
- New optional engine rating of 245HP/505 ft-lbs for the six-speed transmission.

Models Available:

- 2500HD as Standard Cab, Quad Cab, short bed, long bed, cab chassis, 4x2 and 4x4.
- 3500 same as above except no short beds.

Engine Ratings:

- 235 HP 460 ft-lbs torque for five-speed manual and automatic transmissions.
- 245 HP 505 ft-lbs torque (HO engine) for six-speed manual transmission only.

Transmissions:

- Five-speed manual NV4500HD: 5th overdrive.
- Six-speed manual NV5600: 6th overdrive, available only with the HO engine.
- Four-speed automatic 47RE: 4th overdrive with locking converter.

Maximum Tow Ratings:

- 2500 Regular Cab and Quad Cab, 4x2 and 4x4, both manual transmissions, both axle ratios, 20,000 GCWR.
- 3500 Regular Cab and Quad Cab, 4x2 and 4x4, both manual transmissions, both axle ratios, 20,000 GCWR. Exception: 3500 4x2 and 4x4 six-speed manual with 4.10 axle is rated at 21,500 GCWR.
- 2500 and 3500 Regular Cab and Quad Cab, 4x2 and 4x4 with automatic transmissions are rated 3.54 axle=16,000 GCWR, 4.10= 18,000 GCWR.

Note: Maximum permissible trailer weight will vary by model and options. Highest trailer weight rating is for a 3500 Regular Cab 4x2 six-speed 4.10 axle= 15,150 pounds. Lowest trailer weight rating is for a 3500 Quad Cab 4x4 automatic 3.54 axle= 9,000 pounds.

Cab/Chassis Models:

Available in Regular Cab only. 2500 is 8,800 GVWR, 56" C/A dimension. 3500 is 11,000 GVWR and is available in 60" and 84" C/A dimensions. Tow ratings are same as above with maximum for 3500 six-speed 4.10 axle of 21,500 GCWR.

Comments:

- The six-speed transmission remains on back order due to high demand.
- New disc brake rear axle and standard 4 wheel ABS greatly enhances stopping ability on '01.5 trucks.
- All truck functions are increasingly controlled by computer electronics.

2002 TURBO DIESEL

What is New:

Although the gas engine 1500 models received a whole new body and interior, the Turbo Diesel 2500 and 3500 model trucks experienced minor trim changes for this model year.

Models Available:

- 2500HD as Standard Cab, Quad Cab, short bed, long bed, 4x2 and 4x4 models.
- 3500HD as Standard Cab, Quad Cab, long bed, 4x2 and 4x4 models.
- The 3500 cab/chassis line is discontinued.

Engine Ratings:

- 235 HP and 460 ft-lbs torque for five-speed manual and 47RE automatic transmissions
- 245 HP and 505 ft-lbs torque (HO engine) for six-speed manual transmission only.

Transmissions:

- Five-speed manual NV4500HD: 5th overdrive.
- Six-speed manual NV5600HD: 6th overdrive.
- Four-speed automatic 47RE: 4th overdrive with locking converter.

Maximum Tow Ratings:

- 2500 Regular Cab and Quad Cab, 4x2 and 4x4, both manual transmissions and both axle ratios, 20,000 GCWR.
- 3500 Regular Cab and Quad Cab, 4x2 and 4x4, both manual transmissions and both axle ratios, 20,000 GCWR.
- 2500 and 3500 Regular Cab and Quad Cab, 4x2 and 4x4 with automatic transmissions are rated: 3.54 axle = 16,000 GCWR, 4.10 = 18,000 GCWR.

Note: Maximum permissible trailer weight will vary by model and options. Highest trailer weight ratings is for a 3500 Regular Cab, 4x2, six-speed manual, 4.10 axle = 15,150 pounds. Lowest trailer weight rating is for a 3500 Quad Cab 4x4, automatic 3.54 axle = 9,000 pounds.

Cab Chassis Models:

Discontinued. However commercial owners could order a "box delete" option.

Comments:

This is the first full model year of production of rear disc brakes with standard four-wheel antilock brakes.

THIRD GENERATION

2003 TURBO DIESEL

What is New:

- All new body and cab interior layouts. It is called "Third Generation" by Turbo Diesel enthusiasts.
- New full four-door cab option with forward hinged rear doors is still called the Quad Cab.
- New hydro-formed boxed frame for greater rigidity.
- New High Pressure, Common Rail diesel engine fuel injection system eliminates distributor-type fuel injection pump. New engine meets tighter emission control standards while offering more power.
- Driving axles are now supplied by American Axle in ratios of 3.73 and 4.10 to 1.
- The 4x2 models get new rack and pinion steering system, while 4x4 models retain recirculating ball system of previous models.
- All models use 17-inch wheels and tires.
- The 3500 model is available with either single or dual rear wheels.

Models Available:

- 2500HD as Standard Cab, Quad Cab (full size rear doors) short bed, long bed, 4x2 and 4x4.
- 3500HD is available in single rear wheel and dual rear wheel versions. Dual wheel version has higher weight and towing capacities. Dual wheel version is not offered with a short box.

Engine Ratings:

- 235 HP and 460 ft-lbs torque for 47RE automatic. The states of CA, ME, MA are only offered the 235 HP/460 ft.-lbs. engine.
- 250 HP and 460 ft-lbs torque for the 48RE automatic (introduced mid-year as an 03.5) and five-speed manual transmission.
- 305 HP and 555 ft-lbs torque high output (HO) engine with six-speed manual only.

Transmissions:

- Five-speed manual NV4500HD: 5th overdrive only with standard engine.
- Six-speed manual NV5600HD: 6th overdrive only with HO engine.
- In the first half of the 2003 model year the four-speed automatic 47RE 4th overdrive with locking converter only with standard engine.
- In January of 2003 Dodge released the 48RE automatic transmission 4th overdrive with locking converter

Maximum Tow Ratings:

- 2500 Regular Cab and Quad Cab, 4x2 and 4x4, five-speed, 250 hp engine:
 - 3.73 differential – 19,000 GCWR/18,000 GCWR for the states of CA, ME, MA.
 - 4.10 differential – 20,000 GCWR.
- 2500 Regular Cab and Quad Cab, 4x2 and 4x4, 47RE

automatic transmission, 235 hp engine:

- 3.73 differential – 18,000 GCWR/17,000 GCWR for the states of CA, ME, MA.
- 4.10 differential – 20,000 GCWR/19,000 GCWR for the states of CA, ME, MA.
- 2500 Regular Cab and Quad Cab, 4x2 and 4x4, six-speed or 48RE automatic transmission. 3.73 or 4.10 differential, High Output/305 hp engine – 20,000 GCWR.
- 3500 Regular Cab and Quad Cab, 4x2 and 4x4, five-speed, 250 hp engine, single or dual rear wheels:
 - 3.73 differential – 19,000 GCWR/18,000 GCWR for the states of CA, ME, MA.
 - 4.10 differential – 21,000 GCWR/20,000 GCWR for the states of CA, ME, MA.
- 3500 single or dual wheels, Regular Cab and Quad Cab, 4x2 and 4x4, 47RE automatic transmission, 235 hp engine:
 - 3.73 differential – 18,000 GCWR/17,000 GCWR for the states of CA, ME, MA.
 - 4.10 differential – 20,000 GCWR/19,000 GCWR for the states of CA, ME, MA.
- 3500 Regular Cab and Quad Cab, 4x2 and 4x4, six-speed or 48RE transmission, High Output/ 305 hp engine:
 - 3.73 differential – 21,000 GCWR.
 - 4.10 differential – 23,000 GCWR.

Summary: Varies with model and options. Maximum tow rating is a 3500 series with Standard Cab, long bed, manual transmission, 4x2, 4.10 axle ratio = 23,000 GCWR.

Cab/Chassis Models:

Not offered by the factory. However, commercial owners could order a "box delete" option.

Comments:

This all-new body and cab interior layout also features options not previously offered. American rear axle features a larger ring and pinion set for greater strength and durability. New body gets new exterior paint colors and new interior upholstery colors and options. Cummins badging is moved from front doors to front fender edges near bumper.

At mid-year the 47RE automatic transmission was discontinued. The 305 hp High Output engine was matched to a NV5600 six-speed manual transmission and a new 48RE automatic transmission.



Dawna Eickhoff

A '03-newer Third Generation truck.
(TDR Member Archives)

2004 TURBO DIESEL

also 2004.5 models

What is New:

- See 2003 model for description of new body and frame.
- Minor trim and color changes.
- 2004 model engine ratings and transmission choices are different for California, Maine, Massachusetts, New York and Vermont. These states were given the 235 HP/460 ft-lbs engine only.
- At mid-year the 2004.5 engine with 325 HP and 600 ft-lbs torque is released. With its mid-year introduction this engine is now the only engine offered (50-state certified).
- Five-speed manual transmission is not offered in 2004.5 models with 325/600 engine.
- 2004.5 model is offered with updated 48RE automatic transmission.
- 3500 Quad Cab, short bed now offered.
- 7/70 powertrain warranty, 7/100,000 Cummins engine warranty.

Models Available:

- 2500HD as Standard Cab, Quad Cab, short bed, long bed, 4x2 and 4x4.
- 3500HD same as above. The dual wheel 3500 is not offered with a short box.

Engine Ratings:

- The 2004 engine is 305 HP and 505 ft-lbs and is available with six-speed manual and 48RE automatic. The states of CA, ME, MA, NY, VT are only offered the 235 HP/460 ft-lbs engine for the first half of the year.
- The 2004.5 engine is 325 HP and 600 ft-lbs torque as standard with no optional engine. Offered only with six-speed manual or 48RE automatic. This 50 state engine was/is equipped with a catalytic converter.

Transmissions:

- Early 2004 models for California, Maine, Massachusetts, New York and Vermont: five-speed manual, NV4500HD 5th overdrive.
- All other states: six-speed manual, NV5600HD 6th overdrive. Four-speed automatic 48RE 4th overdrive with revised torque converter lockup clutch programming.

Differential Ratios Offered:

3.73 and 4.10 to 1

Maximum Tow Ratings:

2500 Regular Cab and Quad Cab, 4x2 and 4x4, 235 HP/460 ft-lbs torque engine in the states of California, Maine, Massachusetts, New York and Vermont:

- Five-speed, 3.73 differential – 18,000 GCWR
- Five-speed, 4.10 differential – 20,000 GCWR
- 48RE automatic, 3.73 differential – 17,000 GCWR
- 48RE automatic, 4.10 differential – 19,000 GCWR

All other states with the 305 HP/505 ft-lbs engine or the 2004.5 325 HP/600 ft-lbs engine (all states approved) were shown to have a 20,000 GCWR regardless of transmission or axle ratio.

- 3500 single or dual wheels, Regular Cab and Quad Cab, 4x2 and 4x4, 235 HP/460 ft-lbs torque engine in the states of California, Maine, Massachusetts, New York and Vermont:

- Five-speed, 3.73 differential – 18,000 GCWR
- Five-speed, 4.10 differential – 20,000 GCWR
- 48RE automatic, 3.73 differential – 17,000 GCWR
- 48RE automatic, 4.10 differential – 19,000 GCWR

- All other states with the 305 HP/505 ft-lbs engine or the 2004.5 325HP/600 ft-lbs engine (all-states approved), with either an automatic transmission or six-speed:

- 3.73 differential – 21,000 GCWR
- 4.10 differential – 23,000 GCWR

Summary: Varies by model and options. Maximum is Quad Cab or Standard Cab 4x2, six-speed manual, 4.10 axle ratio, 4x2 = 23,000 GCWR.

Cab Chassis Models:

- Not offered by the factory. However, commercial owners could order a "box delete" option.

Comments:

The 2004 model year was an exciting one for Dodge/Cummins fans. At year end, the bragging rights to the most powerful diesel engine belonged to Ram owners with an engine certification of 325 HP/610 ft-lbs torque. It is interesting to watch as the horsepower race continues.

2005 TURBO DIESEL

What is New:

- Polished aluminum wheel replaces the painted aluminum wheel on 2500/3500 SRW models.
- Optional on the Quad Cab are a power sunroof and satellite radio.
- The Cummins 325/600 engine was voted one of the "10 Best Engines" by Ward's

Models Available:

- 2500HD as Standard Cab, Quad Cab, short bed, long bed, 4x2 and 4x4.
- 3500HD same as above. The dual wheel 3500 is not offered with a short box.

Engine Ratings:

- For 2005 the only rating offered is 325 HP and 610 ft-lbs torque. The engine is 50-state approved.

Transmissions:

- Throughout the 2005 model year the New Venture NV5600, six-speed manual was replaced by a Mercedes Benz designed G56 six-speed manual transmission. The reason for the change: New Venture Gear was a joint venture company between DaimlerChrysler and GM. In December of 2002 the partnership was dissolved and New Venture was/is wholly owned by GM.

The ratios of the NV5600 versus the G56 are shown below:

	1	2	3	4	5	6	R
G56	6.29	3.48	2.10	1.38	1.0	.79	5.74
NV5600	5.63	3.38	2.04	1.39	1.0	.73	5.63

The automatic transmission remained the 48RE.

Differential Ratios Offered:

- 3.73 and 4.10 to 1

Maximum Tow Ratings:

In the 2005 Ram Truck brochure the factory simply lists payload and towing weights. With the previous GCWR numbers we've used, the reader knows that the maximum trailer weight plus weight of the truck equals the GCWR. Effectively, the heavier the truck is, the *less* the trailer can weigh to not exceed the GCWR.

The 2005 brochure does not list truck weight or the TDR would do-the-math in order to present consistent data to you. The data we have is presented below:

2005 Payload and Towing Maximums

	Payload	Trailer Weight
2500		
Regular Cab 4x2	2740	13,600
Regular Cab 4x4	2340	13,200
Quad Cab 4x2	2520	13,350
Quad Cab 4x4	2230	13,100
3500		
Regular Cab 4x2	4910	16,250
Regular Cab 4x4	5200	15,850
Quad Cab 4x2	4550	16,300
Quad Cab 4x4	4840	15,950

Cab Chassis Models:

Not offered by the factory. However, commercial owners could order a "box delete" option.

2006 TURBO DIESEL

What is New:

In the fall of 2005, Dodge introduces the Mega Cab as a 2006 model. Although it has four doors, the current Quad Cab has always been seen by Dodge as an Extended Cab model.

As its entry into the Crew Cab marketplace, the Dodge Mega Cab boastfully features the following largest/best-in-class attributes:

- Largest, longest cab – 143.2 cubic feet, 111.1 inches long
- Largest interior cargo volume – 72.2 cubic feet
- Largest cargo volume behind rear seat – 7.7 cubic feet
- Largest flat floor load area – 16.8 square feet
- Largest second-row leg room – 44.2 inches
- Largest rear-door opening – 34.5 inches wide, 35.5 inches tall
- Largest rear-door open angle – 85 degrees
- First-ever reclining rear seats – 22 to 37-degree seat-back angle

Going hand-in-hand with the Mega Cab introduction, Dodge redesigned the interior dash and seats. A minor facelift to the truck's headlights, bumper and grill were a part of the 2006 introduction.

In the spring of 2006 Dodge introduced the Chassis Cab truck for commercial markets. The truck started production in the summer months and was officially known as a 2007 model. The engine for the Chassis Cab was a new 6.7-liter Cummins Turbo Diesel.

This 6.7 liter engine will be used in the pickup trucks in 2007 as it was designed to meet the tighter 2007 emissions regulations.

Models Available:

- 2500HD as Standard Cab, Quad Cab, short bed, long bed, 4x2 and 4x4.
- 3500HD same as above. The dual wheel 3500 is not offered with a short box.

The Mega Cab is offered only with a short box. With the dual rear wheel/3500 Mega Cab, Dodge had to introduce a short box option.

Chassis Cab Models:

- Introduced in March of 2006 the Commercial Chassis Cab trucks are initially available as a 3500 series truck. The 3500 series truck is available in single or dual rear wheels (SRW/DRW). The truck is available in both Regular Cab and Quad Cab configurations. The Regular Cab can be purchased with a 60-inch cab-to-rear axle length or a 84-inch cab-to-axle. The Quad Cab can only be purchased with a 60-inch cab-to-rear axle length.

Engine Ratings:

- Again, for 2006 the only engine offered is the 50-state approved, 325 HP and 610 ft-lbs torque Cummins Turbo Die3sel.
- The Chassis Cab gets the 6.7 liter Cummins engine rated at 305 HP and 610 ft-lbs torque.

Transmissions:

- Consumer pickup models 2500 and 3500 – no changes from 2005.
- Commercial Cab and Chassis 3500 – G56, six-speed manual transmission (same as consumer pickup), Aisin AS68RC, six-speed automatic transmission.
- The Aisin internal gear ratios are as follow:

Aisin AS68RC					
1	2	3	4	5	6
3.74	2.00	1.34	1.00	.77	.63

Differential Ratios Offered:

- 3.73 and 4.10 to 1
- Both the 3.73 and 4.10 are offered in consumer pickup models 2500 and 3500.
- In the Chassis Cab model 3500 both the 3.73 and 4.10 are available with the G56 manual transmission. The 4.10 is the only axle ratio offered with the Aisin AS68RC automatic transmission.

Maximum Towing Capacities:

With the single power offering of 325 HP/610 ft-lbs torque the GCWR towing capacities are simplified. The numbers below are for Regular, Quad and Mega Cab trucks.

- 2500 Manual or Automatic transmission with a 3.73 differential – 20,000
- 3500 Automatic transmission, 4.10 differential – 20,000
- 3500 Automatic transmission, 3.73 differential – 21,000
- 3500 Automatic transmission, 4.10 differential – 23,000
- 3500 Manual transmission, 3.73 differential – 23,000

2007 TURBO DIESEL

What is New:

- Mid-year introduction (2007.5) of Cummins 6.7 liter engine in consumer pickup models 2500 and 3500. Mid-year introduction of a Chrysler-supplied 68RE, six-speed automatic transmission.
- Mid-year introduction (February 2007) of commercial Chassis Cab models 4500 and 5500. These trucks would officially be labeled as 2008 model year vehicles.

Models Available:

- Same as 2006.
- 2500HD as Standard Cab, Quad Cab, short bed, long bed, 4x2 and 4x4.
- 3500HD same as above. The dual wheel 3500 is not offered with a short box.
- The Mega Cab is available in the 2500 or 3500 single rear wheels, or 3500 dual rear wheels. It is only offered with a short cargo box.

Chassis Cab Models:

The Commercial Chassis Cab trucks are initially available as a 3500 series truck. The 3500 series truck is available in single or dual rear wheels (SRW/DRW). The truck is available in both Regular Cab and Quad Cab configurations. The Regular Cab can be purchased with a 60-inch cab-to-rear axle length or a 84-inch cab-to-axle. The Quad Cab can only be purchased with a 60-inch cab-to-rear axle length.

Engine Ratings:

- For early '07 models, 325 HP and 610 ft-lbs for consumer pickup models 2500 and 3500. This is a carry-over of the Cummins 5.9 liter engine.
- The 2007.5 consumer pickup models 2500 and 3500 received the Cummins 6.7 liter engine rated at 350 HP and 650 ft-lbs torque with the automatic transmission, 350HP and 610 ft-lbs torque with the manual transmission.
- The engine was introduced in January 2007 to meet a more stringent set of diesel exhaust emissions standards. The engine and its exhaust aftertreatment components were praised by the press as the engine not only met the 2007 standards, it also met the upcoming 2010 emissions standards. The fact that no further changes would be necessary for 2010 gave Dodge and Cummins an advantage over competitive engines that would go through two sets of hardware changes.
- The 6.7-liter's introduction was not without its own set of problems. Multiple software calibrations were implemented to solve problems with soot. This engine, with its electronic controls, NOx filter, and particulate filter, does not lend itself to "hot rodding" as did the previous 5.9-liter engine.
- 305 HP and 610 ft-lbs for commercial Chassis Cab 3500 models using the Cummins 6.7 liter engine. The 4500 and 5500 trucks are introduced with the same engine and engine ratings as the 3500 Chassis Cab.

Transmissions:

- For early 2007 the consumer pickup models 2500 and 3500 used the existing G56, six-speed manual transmission and 48RE, four-speed manual transmission.
- With the mid-year (2007.5) introduction of the 6.7 liter engine the automatic transmission was revised to a Chrysler-supplied 68RFE, six-speed unit.

48 RE Versus 68RFE Gear Ratio Comparison

		1	2	3	4	5	6
'03.5-'07	48RE	2.45	1.45	1.0	.69		
'07.5-newer	68RFE	3.23	1.84	1.41	1.00	.82	.63

- With the mid-year (2007.5) introduction of the 6.7-liter engine the manual transmission (the Mercedes Benz designed G56 six-speed unit) was revised. In order to raise the overall gear ratios in the manual transmission the redesign dropped a tooth on the input shaft. The resulting gear ratios are as follow.

G56 Versus G56R Gear Ratio Comparison

		1	2	3	4	5	6
'05-'07	G56	6.26	3.48	2.10	1.38	1.00	.79
'07.5-newer	G56R	5.94	3.28	1.98	1.31	1.00	.74

- Commercial Cab Chassis – no changes from 2006: G56R, six-speed manual transmission and Aisin AS68RC, six-speed automatic transmission.

Differential Ratios Offered (Consumer 2500/3500 trucks):

- With the mid-year (known as '07.5) change to the Cummins 6.7-liter engine there was also a change in the differentials that were offered by Dodge. Starting mid-year:
 - 3.43 and 3.73 with the G56R manual transmission
 - 3.43, 3.73 and 4.10 with the 68RFE automatic transmission

Differential Ratios Offered (Chassis Cab 3500):

- In the Chassis Cab model 3500 both the 3.73 and 4.10 are available with the G56 manual transmission. The 4.10 is the only axle ratio offered with the Aisin AS68RC automatic transmission

Maximum Towing Capacities:

- Again in 2007, with the single power offering of 325 HP/610 ft-lbs torque the GCWR towing capacities are simplified. The numbers below are for regular, Quad and Mega Cab trucks.
 - 2500 Manual or Automatic transmission with a 3.73 differential – 20,000
 - 2500 Automatic transmission, 4.10 differential – 20,000
 - 3500 Automatic transmission, 3.73 differential – 21,000
 - 3500 Automatic transmission, 4.10 differential – 23,000
 - 3500 Manual transmission, 3.73 differential – 23,000

2008 TURBO DIESEL

What is New:

- Introduced to the public in February 2007 at the Chicago Auto Show, the Chassis Cab models 4500 and 5500 were officially known as 2008 model trucks. These Chassis Cab trucks share the same powertrain as the 3500 truck that was introduced in March of 2006. For the 4500 and 5500 trucks the differentials are larger. The front axle is made by Magna, the rear axle is made by Dana.
- Available gearing for the existing 3500 Chassis Cab:
 - 3.73 and 4.10 with the manual transmission
 - 4.10 with the automatic transmission
- Available gearing for the 4500 Chassis Cab:
 - 4.10 and 4.44 to 1 for the manual transmission
 - 4.44 and 4.88 to 1 for the automatic transmission
- Available gearing for the 5500 Chassis Cab:
 - 4.44 and 4.88 to 1 for the manual transmission
 - 4.88 to 1 for the automatic transmission

Models Available:

- Same as 2006 and 2007
- 2500 HD as Standard Cab, Quad Cab, with short bed or long bed in 4x2 and 4x4 configurations.
- 3500 HD same as above, although the dual wheel 3500 is not offered with a short box.
- The Mega Cab is available in the 2500 or 3500 single rear wheels, or 3500 dual rear wheels. It is only offered with a short cargo box.

Chassis Cab Models:

- The 3500 is available in single or dual rear wheels
- The 4500 and 5500 are dual rear wheels.
- All three Chassis Cabs are available with a Regular Cab or Quad Cab configuration.
- With the 3500, the Regular Cab can be purchased with a 60-inch cab-to-rear axle length or a 84-inch cab-to-axle length with single or dual rear wheels (SRW/DRW). The 3500 Quad Cab can only be purchased with the 60-inch cab-to-rear axle length with SRW or DRW.
- The 4500 and 5500 trucks are only offered with dual rear wheels. These trucks allow Regular Cab or Quad Cab cabins to be used with the 60-inch or 84-inch cab-to-axle length.

Engine Ratings:

- Same as 2007.5
- For 2008 the engine ratings for the Cummins 6.7-liter engine in consumer pickup models 2500 and 3500 remained the same as they were when the 6.7-liter engine was introduced in January of 2007: 350 HP and 650 ft-lbs of torque with the automatic transmission and 350 HP and 610 ft-lbs of torque with the manual transmission.
- The engine ratings for the Cummins 6.7-liter engine in the Chassis Cab models 3500, 4500 and 5500 remained the same as they were when the engine was introduced in the first Chassis Cab 3500 model in March of 2006: 305 HP and 610 ft-lbs of torque.

Transmissions:

- Same as 2007.5
- In the consumer pickup models 2500 and 3500 the automatic and manual transmission are the same as those used in the '07.5 introduction of the Cummins 6.7-liter engine in January of 2007. The nomenclature for the automatic transmission is the 68RFE; the nomenclature for the manual transmission is G56R. The gear ratio comparison chart is found in the "2007 Turbo Diesel" write-up.
- Commercial Chassis Cab models 3500, 4500, 5500 get the revised G56R manual transmission. The Aisin AS68RC six-speed automatic transmission is the same as the initial offering of the first Chassis Cab 3500 model in March of 2006.

Differential Ratios Offered (Consumer 2500/3500 trucks):

- Same as 2007.5.
 - 3.43 and 3.73 with the G56R manual transmission
 - 3.43, 3.73 and 4.10 with the 68RFE automatic transmission.

Differential Ratios Offered (Chassis Cab 3500/4500/5500):

- In the Chassis Cab models both the 3.73 and 4.10 are available with the G56 manual transmission. The 4.10 is the only axle ratio offered with the Aisin AS68RC automatic transmission

Maximum Towing Capacities:

- In the 2008 Ram Truck brochure the factory has gone back to the rating guidelines that they used in 2005 whereby they simply list the payload and towing weights. With previous GCWR numbers the reader knows the maximum trailer weight plus the weight of the truck equals the GCWR. Effectively, the heavier the truck is, the less the trailer can weigh in order to not exceed the GCWR.
- The 2008 brochure does not list the truck weight or the TDR would do-the-math in order to present consistent data to you. The data we have from the 2008 brochure is presented below:

	Payload	Trailer Weight
2500		
Regular Cab 4x2	2,680	13,550
Regular Cab 4x4	2,270	13,100
Quad Cab 4x2	2,520	13,350
Quad Cab 4x4	2,070	12,900
M0p1ega Cab 4x2	2,050	12,850
Mega Cab 4x4	1,520	12,350

3500 (DRW equipped/4.10 axle)

Regular Cab 4x2	4,790	16,150
Regular Cab 4x4	5,120	16,750
Quad Cab 4x2	4,480	16,150
Quad Cab 4x4	4,780	16,750
Mega Cab 4x2	3,200	15,550
Mega Cab 4x4	2,770	16,100

2009 TURBO DIESEL

What is New:

- Although the Dodge Ram 1500 model received a new body and interior, the Turbo Diesel 2500 and 3500 consumer pickups and 3500, 4500, 5500 Chassis Cab trucks saw only minor trim revisions in this carryover/transitional model year.

Models Available:

- Same as 2006, 2007, and 2008
- 2500 HD as Standard Cab, Quad Cab, with short bed or long bed in 4x2 and 4x4 configurations.
- 3500 HD same as above, although the dual wheel 3500 is not offered with a short box.
- The Mega Cab is available in the 2500 or 3500 single rear wheels, or 3500 dual rear wheels. It is only offered with a short cargo box.

Chassis Cab Models:

- Same as 2008.
- The 3500 is available in single or dual rear wheels
- The 4500 and 5500 are dual rear wheels.
- All three Chassis Cabs are available with a Regular Cab or Quad Cab configuration.
- With the 3500, the Regular Cab can be purchased with a 60-inch cab-to-rear axle length or a 84-inch cab-to-axle length with single or dual rear wheels (SRW/DRW). The 3500 Quad Cab can only be purchased with the 60-inch cab-to-rear axle length with SRW or DRW.
- The 4500 and 5500 trucks are only offered with dual rear wheels. These trucks allow Regular Cab or Quad Cab cabs to be used with the 60-inch or 84-inch cab-to-axle length.

Engine Ratings:

- Same as 2007.5 and 2008.
- In consumer pickup models 2500 and 3500: 350 HP and 650 ft-lbs of torque with the automatic transmission and 350 HP and 610 ft-lbs of torque with the manual transmission.
- The engine ratings for the Cummins 6.7-liter engine in the Chassis Cab models 3500, 4500 and 5500 remained the same when the engine was introduced in 2006: 305 HP and 610 ft-lbs of torque.

Engine Changes for 2009:

- Starting in '02, the heavy duty trucks' introduction has followed the Dodge Ram 1500 by one year. The model year 2009 heavy duty trucks are no exception, they continue with the same cab and chassis design. As you can expect there are only a few subtle changes to the engine. These changes are:
 - Access port on the turbocharger's exhaust housing that allows for exhaust turbine cleaning as needed.
 - Revised stamped steel alternator bracket.

- Revised coolant hoses and O-ring fittings for the plumbing that goes to cool the exhaust gas recirculation heat exchanger.
- Revised fuel filter assembly that features a dual filter with greater filter area to strip away water as well as a secondary fuel filter with a smaller 5-micron rating. (The current fuel filter is 7-micron). The new fuel filter was released for production in January and the part can be retrofitted to the '07.5 to early '09 engines. Service parts for these engines were released in July 2009.
- Revised water inlet housing.

Transmissions:

- In the consumer pickup models 2500 and 3500 the automatic and manual transmission are the same as those used in the '07.5 and '08. The nomenclature for the automatic transmission is the 68RFE; the nomenclature for the manual transmission is G56R. The gear ratio comparison chart is found in the "2007 Turbo Diesel" write-up.
- Commercial Chassis Cab models 3500, 4500, 5500 use the same G56R manual transmission and Aisin AS68RC six-speed automatic transmission.

Differential Ratios Offered (Consumer 2500/3500 trucks):

- Same as 2007.5 and 2008.
 - 3.43 and 3.73 with the G56R manual transmission
 - 3.43, 3.73 and 4.10 with the 68RFE automatic transmission.

Differential Ratios Offered (Chassis Cab 3500/4500/5500):

- In the Chassis Cab models both the 3.73 and 4.10 are available with the G56 manual transmission. The 4.10 is the only axle ratio offered with the Aisin AS68RC automatic transmission

Maximum Towing Capacities:

- No changes from the listing chart for 2008.

FOURTH GENERATION

2010 TURBO DIESEL

What is New:

- All new body and cab interior layouts. The 2010 trucks are called "Fourth Generation" by Turbo Diesel enthusiasts.
- For 2010, the introduction of the heavy duty pickups (2500 and 3500 series) was one year after the introduction of Dodge's 1500 series truck. This one-year-later protocol mirrors the introduction of the Third Generation truck: Dodge introduced the 1500 trucks in 2002, the heavy duty 2500 and 3500 trucks were introduced in 2003. So, although some may look back and try to correlate the one-year difference due to Chrysler's financial woes of 2009, such is not the case with the heavy duty 2500 and 3500 consumer pickup trucks.
- The same cannot be said for the 3500/4500/5500 commercial Chassis Cab trucks. They were scheduled for 2010 introduction, but were delayed until mid-year 2010 and Dodge chose to call the trucks 2011 model year vehicles.
- Therefore, our focus on "What is New" for this section of the Buyer's Guide will pertain to the 2500 and 3500 consumer pickup trucks only. The commercial Chassis Cabs are a carryover from 2009.
- If you look backward to the year 2003 and the introduction of the Third Generation truck you'll see that there were sweeping changes to the truck's frame and chassis. And, if you followed Dodge's introduction of the 1500 pickup truck as a 2009 model, you would also note big changes to the truck's frame, chassis and rear suspension as Dodge introduced rear suspension coil springs in lieu of the traditional leaf springs. This gave the 1500 truck a more compliant ride with only a small sacrifice in load capacity.
- For 2010 two of the frames for the 2500 and 3500 consumer pickup trucks were brought over from the previous generation trucks with the 140.5 wheelbase and the 160.5 wheelbase. New for 2010 are the 149.5 and 169.5 wheelbase platforms.

Models Available:

- What, no Quad Cab? In a departure from the Third Generation truck where wheelbase dimensions and interior configurations were shared with the smaller 1500 series truck, the 2010 Ram 2500 and 3500 trucks do not offer the interior configuration known as a Quad Cab. A quick look at the wheelbase options for the 1500 truck reveals that it is offered with a 120 and 140 inch wheelbase. On the 1500 truck's 120" wheelbase Dodge offers a Regular Cab with a 6'4" bed. On their 140" wheelbase you could order:

Regular Cab, 8' bed
Quad Cab, 6'4" bed
Crew Cab, 5'7" bed

Focus on Heavy Duty Trucks

- As mentioned, the 2500 and 3500 trucks start the product offering with a 140.5 wheelbase and the Quad Cab interior is not available with the bigger trucks.
- In the previous Third Generation truck there were two wheelbases that were used, a 140.5 platform (Regular Cab/8' bed and Quad Cab/6' bed), and the 160.5 platform (Quad Cab/8' bed and Mega Cab/6' bed).
- It is our understanding that many of the underpinnings for 2010 Heavy Duty are carried over from the proven Third Generation chasses. However, the tale-of-the-tape shows, as mentioned, two that were carried over and two new wheelbases and the various truck configurations for 2010:

140.5 platform

2500	Regular Cab/8' box
3500 SRW	Regular Cab/8' box

149.5 platform (new platform)

2500	Crew Cab/6'4" box
3500 SRW	Crew Cab/6'4" box

160.5 platform (new platform)

2500	Mega Cab/6'4" box
3500 SRW	Mega Cab/6'4" box
3500 DRW	Mega Cab/6'3" box

169.5 platform (new platform)

2500	Crew Cab/8' box
3500 SRW	Crew Cab/8' box
3500 DRW	Crew Cab/8' box

(effectively a Third Generation truck)*

Chassis Cab Models:

- As noted in the introduction, the 2010 Chassis Cab was carried over from 2009, thus this truck is the same as 2006, 2007 and 2008.*
- The 3500 is available in single or dual rear wheels.
- The 4500 and 5500 are dual rear wheels.
- All three Chassis Cabs are available with a Regular Cab or Quad Cab configuration.
- With the 3500, the Regular Cab can be purchased with a 60-inch cab-to-rear axle length or a 84-inch cab-to-axle length with single or dual rear wheels (SRW/DRW). The 3500 Quad Cab can only be purchased with the 60-inch cab-to-rear axle length with SRW or DRW.
- The 4500 and 5500 trucks are only offered with dual rear wheels. These trucks allow Regular Cab or Quad Cab cabins to be used with the 60-inch or 84-inch cab-to-axle length.
- Economically for Chrysler, 2010 was a difficult year. Although press release notes and literature show that the 2010 Chassis Cab was *scheduled* to receive the Fourth Generation cabin, my notes show that the Chassis Cab did not show up at the dealer showroom with the new cabin until 2011.

Engine Ratings:

- If you look back to the write-up on the “2007 Turbo Diesel—Engine Ratings” you will find that the mid-year (2007.5) introduction of the 6.7-liter engine was done to meet more stringent emissions standards. The write-up also explains that this engine was also designed to meet the 2010 emissions standards.
- Long story, short version: for 2010 the engine ratings for the Cummins 6.7-liter engine in consumer pickup models 2500 and 3500 remained the same as they were when the engine was introduced in January of 2007 with a 2007.5 model year designation: 350 HP and 650 ft-lbs of torque with the automatic transmission and 350 HP and 610 ft-lbs of torque with the manual transmission.
- The engine ratings for the Cummins 6.7-liter engine in the Chassis Cab models 3500, 4500 and 5500 remained the same when the engine was introduced in the first Chassis Cab 3500 model in March of 2006: 305 HP and 610 ft-lbs of torque.

Engine Changes for 2010:

Turbo Diesel owners know that the powertrain for the 2010 Heavy Duty truck is, for the most part, a carry over from the previous Third Generation truck. Therefore you will not find any change to the air filter, oil filter or transmission filters. However, the fuel filter, belts and hoses have been changed for 2010.

	Mopar	Fleetguard
Carryover Parts		
Air Filter	53034051	
Oil Filter	5083285	LF3972/LF16035
Aisin Automatic (4x4 and 4x2)	68019688	
68RFE Automatic 4x4	5013470	
68RFE Automatic 4x2	5179267	
68RFE Automatic Screw-on (4x4 and 4x2)	68019688	

New Parts

Fuel Filter and Cartridge	68065609	
Fuel Filter only	68065608	FS43255

Further Information:

New Powertrain Control Module - The engine-mounted control module is new for MY2010. For pickups with the 68RFE transmission, the new CM2200 integrates engine and transmission control functions into one controller in place of the separate engine and transmission control modules used on prior trucks.

New Fuel Filter - 2010 brings a new fuel filter assembly with improved access for easier and cleaner maintenance. The new fuel filter is serviced from above similar to 5.9's, and the fuel filter drain design has also been updated for easier access. The drain is now utilizes a 1/4-turn valve that can also be easily accessed from above. There is also a new fuel system priming procedure that will be discussed in detail in the next issue.

New Thermostat - The new engines have a 200° thermostat, which is higher than previous Cummins engines. The temperature gauge will read slightly higher than the earlier trucks. It is important to note that the earlier lower temperature thermostat should not be used in newer trucks, as it will cause oil change monitor inaccuracy and other

issues. Similarly, the later 200° thermostat should not be used in earlier trucks.

Maintenance - All of the maintenance intervals remain the same for the new 2010 pickups, with the exception of the removal of the EGR valve cleaning at 67,500 miles. The Closed Crankcase Ventilation filter and EGR cooler maintenance are still required at this interval.

Transmissions:

- In the consumer pickup models 2500 and 3500 the automatic and manual transmission are the same as those used in the '07.5 introduction of the Cummins 6.7-liter engine in January of 2007. The nomenclature for the automatic transmission is the 68RFE; the nomenclature for the manual transmission is G56R. The gear ratio comparison chart is found below.
- Commercial Chassis Cab models 3500, 4500, 5500 offer the G56R manual transmission. The Aisin AS68RC six-speed automatic transmission is the same as the initial offering of the first Chassis Cab 3500 model in March of 2006.

Driveline Notes:

- Engine: Carry-over from Third Generation trucks.
 - Cummins 6.7-Liter
 - 408 cubic inches
 - Bore: 4.21 (107mm)
 - Stroke: 4.88 (124mm)
 - Power: 350hp @ 3000rpm
 - Torque: 650 lb-ft @ 1500rpm
- Transmission: Both the automatic (68RFE) and manual (G56) transmissions are carried over from the Third Generation trucks.

68RFE Automatic (2500 and 3500 trucks)

1	3.231
2	1.837
3	1.41
4	1
5	.816
6	.625
Reverse	4.44

Overall top gear: 2.13 with the 3.42 axle;
2.33 with 3.73 axle; 2.56 with 4.10 axle

G56 Manual

1	5.94
2	3.28
3	1.98
4	1.31
5	1
6	.74
Reverse	5.42

Overall top gear: 2.13 with the 3.42 axle;
2.76 with 3.73 axle; 3.03 with 4.10 axle

Differential Ratios Offered (Consumer 2500/3500 trucks):

- Same as 2007.5 and 2008.
 - 3.43 and 3.73 with the G56R manual transmission
 - 3.43, 3.73 and 4.10 with the 68RFE automatic transmission.

Transfer Cases:

- Carryover from Third Generation trucks.
 - NV 271 (manual) – Standard on base trucks
 - NV 273 (electric) – Optional on SLT trim trucks
Standard on Laramie trim trucks
- Low range ratio: 2.72

Towing Charts:

- For 2010 the available factory specifications are far more detailed than the last data that we had in 2008. For comparison I brought over the data from 2008. Yes, there is quite a bit more data to consider.

	Ratings from 2008		Payload Ratings for 2010		
	Payload	Trailer Weight		Automatic	Manual
2500			2500		
Regular Cab 4x2	2,680	13,550	Regular Cab 4x2	2,590	2,490
Regular Cab 4x4	2,270	13,100	Regular Cab 4x4	2,250	2,140
Quad Cab 4x2	2,520	13,350	*Crew Cab 4x2	2,290	2,190
Quad Cab 4x4	2,070	12,900	*Crew Cab 4x4	2,450	2,370
Mega Cab 4x2	2,050	12,850	Mega Cab 4x2	1,980	1,910
Mega Cab 4x4	1,520	12,350	Mega Cab 4x4	2,140	2,070
3500 (DRW equipped/4.10 axle)			3500 (DRW)		
Regular Cab 4x2	4,790	16,150	Regular Cab 4x2	4,750	4,650
Regular Cab 4x4	5,120	16,750	Regular Cab 4x4	5,130	5,050
Quad Cab 4x2	4,480	16,150	*Crew Cab 4x2	4,280	4,190
Quad Cab 4x4	4,780	16,750	*Crew Cab 4x4	4,760	4,680
Mega Cab 4x2	3,200	15,550	Mega Cab 4x2	3,130	3,060
Mega Cab 4x4	2,770	16,100	Mega Cab 4x4	2,720	2,640

*The Crew Cab numbers in this chart represent the weight value average of the long box and short box configurations.

	Maximum Trailer Ratings for 2010					
	Automatic			Manual		
	<u>3.42</u>	<u>3.73</u>	<u>4.10</u>	<u>3.42</u>	<u>3.73</u>	
2500						
Regular Cab 4x2	10,450	13,450	13,450	12,350	13,350	
Regular Cab 4x4	10,100	13,100	13,100	12,000	13,000	
*Crew Cab 4x2	10,150	13,150	13,150	12,075	13,075	
*Crew Cab 4x4	9,700	12,700	12,700	11,600	12,600	
Mega Cab 4x2	9,850	12,850	12,850	11,750	12,750	
Mega Cab 4x4	9,400	12,400	12,400	11,300	12,300	
3500 (DRW)						
Regular Cab 4x2	10,100	14,100	17,600	12,000	14,000	
Regular Cab 4x4	9,800	13,800	17,300	11,700	13,700	
*Crew Cab 4x2	10,150	14,100	17,150	12,000	14,000	
*Crew Cab 4x4	9,850	13,850	16,850	11,750	13,750	
Mega Cab 4x2	9,800	13,800	16,800	11,700	13,350	
Mega Cab 4x4	9,400	13,400	16,400	13,700	13,350	

*The Crew Cab numbers in this chart represent the weight value average of the long box and short box configurations.

2011 TURBO DIESEL

What is New:

As mentioned in the introduction to the Fourth Generation truck for 2010, the 2010 commercial Chassis Cab trucks were a Third Generation carry over. Finally, in 2011, the Chassis Cab trucks received the new body styling. (Remember the styling and the cabin were previewed to the press in 1500 series trim at the North American International Auto Show in December of 2007. (I can only imagine that it took 4 years for the cabin to migrate to Chassis Cab vehicles because of the difficult economic recession of 2008-2012.)

Models Available:

The 2500 and 3500 consumer trucks are offered in the same configurations and platforms as the 2010 model year.

140.5 platform

2500	Regular Cab/8' box
3500 SRW	Regular Cab/8' box

149.5 platform

2500	Crew Cab/6'4" box
3500 SRW	Crew Cab/6'4" box

160.5 platform

2500	Mega Cab/6'4" box
3500 SRW	Mega Cab/6'4" box
3500 DRW	Mega Cab/6'3" box

169.5 platform

2500	Crew Cab/8' box
3500 SRW	Crew Cab/8' box
3500 DRW	Crew Cab/8' box

Chassis Cab Models:

(See "Notes" at the end of the 2011 article.)

- The 3500 is available in single or dual rear wheels.
- The 4500 and 5500 are dual rear wheels.
- All three Chassis Cabs are available with a Regular Cab or Crew Cab configuration.
- The 3500 truck is offered in three different wheelbase configurations: 143.5; 167.5; and 172.4.
- The 4500/5500 trucks are offered in six different wheelbase configurations: 144.5; 168.5; 192.5; 204.5; 173.4; 197.4.

Engine Ratings (Consumer 2500/3500 trucks):

- Consumer pickup models 2500 and 3500 the ratings offered at the 2011 model year introduction were a carryover from the 2010 model year; 350/650 for the automatic; 350/610 for the manual transmission. Please note that the emissions aftertreatment on the consumer 2500/3500 truck is different than the system used on the commercial chassis cab trucks. The consumer trucks have a NOx catalyst to address NOx emissions. The chassis cab trucks use selective catalyst reduction (SCR) to lower NOx.
- Engine ratings for the consumer market are often influenced by marketing. The "who has the most power" competition between Dodge, Ford, and GM was raised higher in 2010 with Ford and GM offering new engines to meet the 2010 emissions legislation (remember the Dodge/Cummins engine was 2010 certified when it was introduced in

2007.5) as well as higher horsepower ratings. The numbers:

Ford: 390hp/735 torque, then in August 2010 400/800.

GM: 397hp/765 torque.

- Not to be outdone, in February 2011 Dodge/Cummins announced a new "High Output" (HO) rating for the Turbo Diesel engine, still 350 horsepower, but with 800 ft/lb of torque. Actual production of this High Output engine started in April, so effectively the engine was only offered for the last quarter of the 2011 model year.
- Hand-in-hand with the engine's higher torque rating, Dodge offered a special "Max Tow" package so that they could boast the highest gross combined weight rating (GCWR); a 30,000 pound number with a segment-leading 22,700 pound maximum trailer tow rating. As you might correctly conclude, "Max Tow" is a specific truck, a 3500 dually with a 4.10 axle ratio.

Engine Ratings (Chassis Cab 3500/4500/5500):

- The engine ratings for the Cummins 6.7-liter engine in the Chassis Cab models 3500, 4500 and 5500 remained the same when the engine was introduced in 2006: 305hp and 610 ft-lbs of torque.
- However, effective January 1, 2010, there was diesel exhaust emission legislation that forced Dodge and Cummins to add hardware to the truck to address the NOx (oxides of nitrogen) exhaust emission. The technology they used is called selective catalyst reduction or SCR. The hardware needed for the SCR aftertreatment: hot diesel exhaust; a catalytic converter; diesel exhaust fluid (also known as DEF or urea); holding tank and injector for the DEF; and computer control of the DEF injection.

Transmission:

Same as 2010 with both the consumer 2500/3500 trucks and the commercial cab chassis models 3500/4500/5500 trucks.

Towing Charts:

For the consumer 2500/3500 trucks there was only one significant change to the towing chart that was listed for 2010—a change to higher numbers for a 2500 series truck with an automatic transmission and 4:10 differential.

The revision to the chart:

Maximum Trailer Ratings 2011 (revised from 2010)

	Automatic 4.10 ratio
2500	
Regular Cab 4x2	15,450
Regular Cab 4x4	15,050
*Crew Cab 4x2 Short box	15,200
*Crew Cab 4x2 Long box	15,050
*Crew Cab 4x4 Short box	14,700
*Crew Cab 4x4 Long box	14,650
Mega Cab 4x2	14,800
Mega Cab 4x4	14,300

*Unlike the averaging that was done in the 2010 table summary, the Crew Cab numbers in this chart show exactly the numbers in the Ram literature.

The balance of the towing chart for the other consumer 2500 and 3500 trucks is the same as the 2010 chart. I do not have an explanation for the higher numbers that were released for the 2500.

Finally, as was mentioned in the Engine Ratings Section for the 2500/3500 consumer trucks, there was a late 2011 release of the 6.7-liter engine with a revised torque rating of 800 ft-lbs. With this engine there was a release of a "Max Tow" package for a 3500 dually with an automatic transmission and 4.10 differential. This data is not included in the 2011 Towing Chart(s) above.

Notes About 2011:

If you look further in this buyer's guide you'll notice that Dodge uses model codes to spell-out the change to a new vehicle design. Their chart (printed below) clearly shows that the Chassis Cab trucks finally changed to the Fourth Generation body in 2011.

Series	'08	'09	'10	'11	'12
2500 Pickup	DH	DH	DJ	DJ	DJ
3500 Pickup	D1	D1	D2	D2	D2
3500 C/C	DC	DC	DC	DD	DD
4500 C/C	DM	DM	DM	DP	DP
5500 C/C	DM	DM	DM	DP	DP

2011 TURBO DIESEL

What is New:

The world-wide economic recession equates to no real changes to the Ram 2500/3500 consumer trucks or the Ram 3500/4500/5500 chassis cab trucks. Looking back, there were already big plans for the model year 2013 2500/3500 consumer trucks as Ford, GM and Ram continue to battle it out for the title of "Who can tow/haul the most/who has the most power."

So, in a nutshell, the 2012 Turbo Diesel data is the same as that found in the 2011 summary on the preceding pages.

Notes:

EVOLUTION OF THE CUMMINS ENGINE, 1989-CURRENT COVERING 1989-2004

DIESEL EXHAUST EMISSIONS: WHAT DOES IT MEAN TO ME?

To bring you an understanding of the evolution of the Cummins engine in the Dodge pickup truck requires a basic knowledge of diesel exhaust emissions and emission legislation dates. As TDR subscribers know, emission legislation dates are the driving force in the changes to the Cummins engine hardware. To make a boring story (emissions legislation) into a relevant topic, the subject matter has to address "what does it mean to me?" The best way to accomplish this goal is to crank-up the way-back machine and look at the cause and effect relationship between exhaust emissions and engine hardware. Let's take a trip back to the Fall of '97 to learn about our trucks.

After the review of the immediate "what does it mean to me?" material, I'll attempt to tie the big picture together with a look at the changes that have happened over these many years.

BORING STUFF?

While it might be tempting to skip through this subtitle, I'll ask for your concentrated efforts as we simplify (oversimplify?) the two emissions components that concern the diesel engineer: oxides of nitrogen (NO_x) and particulate matter (PM). The following is a definition of these components.

Oxides of Nitrogen (NO_x)

- One of the primary regulated pollutants from diesel engines.
- Reacts with hydrocarbons in the presence of sunlight to form ozone.
- Formed by reaction between nitrogen and oxygen in the combustion chamber.
- NO_x formation increases with higher combustion temperature/efficiency/cylinder pressures.
- Methods of reduction include lower intake manifold temperature, lower in-cylinder temperature, lower water temperature, retarded fuel injection and combustion optimization.
- Potential impacts can be higher fuel consumption and requirement of a more complex cooling system.

Particulate Matter (PM)

- Often visible as black smoke.
- Formed when insufficient air or low combustion temperature prohibits complete combustion of the free carbon.
- Primarily partially burned fuel and lube oil.
- Methods of control include oil consumption reduction, catalytic converters, combustion system development, higher fuel injection pressures, higher power output and lower engine speeds.

Did you note the sharp, ten-fold drop in emissions from year 2004 to 2007? Wow! I recall one of the first TDR magazines stated that emissions were the driving force behind changes to the diesel engine. The 2007 emissions targets nail-home that statement. Certainly ultra-low sulfur fuel will help, but the engineering it will take to meet the targets is difficult to imagine. Note our BITW articles on page 94 and 95 for further insight.

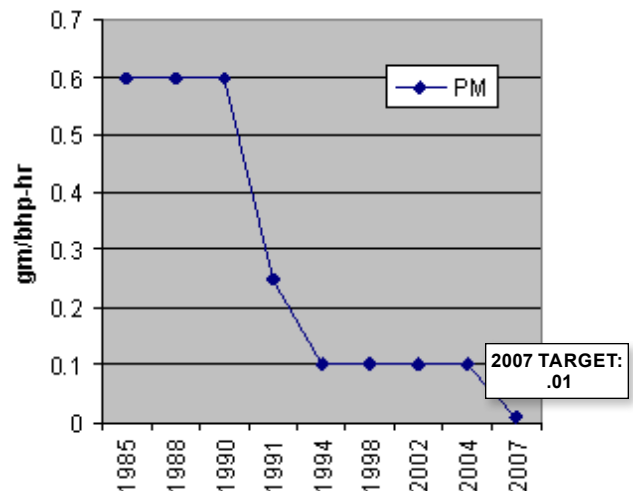
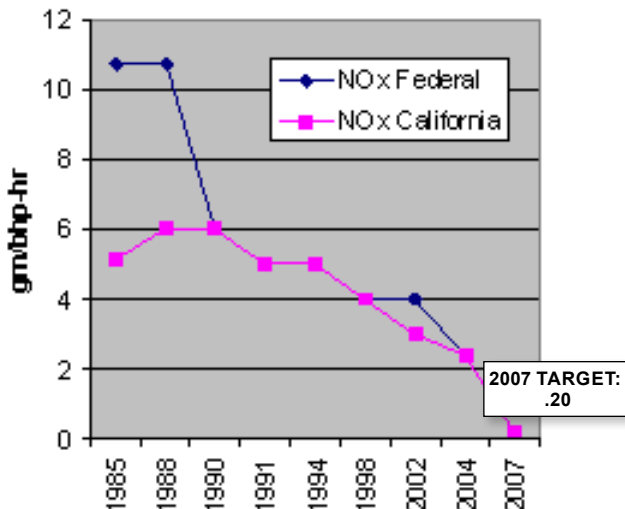

To oversimplify, think back to last winter and the many fireside evenings you enjoyed. As you built the fire, there was inefficient combustion, characterized by black smoke and not much heat generation. Thirty minutes into the exercise you were sitting back in the easy chair, with a raging fire, no more black smoke, a beautiful yellow and blue flame, and lots of heat.

Now, refer back to the NO_x and PM bullet statements and the following realization: the design engineers *could control* particulates (PM) by raising the combustion efficiency (temperatures and pressures). But, raising temperatures and pressures causes the formation of oxides of nitrogen (NO_x) to go out of the emissions “box.” Likewise, efficiency and heat of combustion can be sacrificed to meet the NO_x legislation, but the particulates go out of the emissions “box.” How does the engineer get the teeter-totter level?

As an interesting sidenote, NO_x not only is formed in internal combustion engines, it is the result of elevating air—made up of 79% Nitrogen and 21% Oxygen—to a sufficiently high temperature for the reaction to occur. One of the most significant sources of NO_x formation in nature is lightning.

The reaction that forms NO_x is also time related; the longer the temperature remains elevated, the greater the level of NO_x formation.

In the diesel engine, NO_x formation can be correlated to engine performance; the higher the rate of formation, the more efficient the engine. As most are aware, the impact of reducing NO_x emissions is increased fuel consumption, which is the result of reduced efficiency.

For a good demonstration of the principle, consider that in-cylinder temperatures are much higher on two-stroke engines due to fuel being provided on every stroke. Also, consider the lack of oil control that contributes to too many particulate emissions. These factors made it impossible for two-stroke engines to meet emission targets and maintain fuel consumption and other performance targets. The 1988 on-highway emissions regulations were the final blow to the two-stroke diesel in trucking applications. Two-stroke diesels are now only produced for off-highway and generator set markets.

The method of attack in reducing NO_x formation in the diesel engine is basically twofold: a) reduce the in-cylinder temperature and/or, b) reduce the time for the reaction to occur. The in-cylinder temperature control is handled in part by reduced intake manifold temperature (an intercooler/charge air cooler). Reduced reaction time is controlled largely by retardation of the injector timing. Also note the new-for-2003 Turbo Diesel engine with its common-rail fuel injection system gives a pilot shot of fuel prior to the larger injection event. This pilot shot of fuel helps control the diesel's combustion event and reduces NO_x formation. Pilot injection also has greatly reduced the noise level that is a part of diesel combustion.

BORING TO RELEVANT

As you review the NO_x and PM bullets, you can understand the balancing act the engineer has to accomplish. Now, add to the emissions teeter-totter the need for the engine to maintain or show an increase in fuel economy. Further, competition dictates higher performance from the engine. Quite a job for the engineering community. With the background lesson on emissions out of the way, let's review some of the changes in hardware to the B 5.9 liter engines that have been used in the Turbo Diesel pickup over its 14 years of production.

'91 - '93 TRUCKS

1991-1993 Horsepower Ratings

Horsepower ratings for both the automatic and five-speed trucks stayed the same from the date of the truck's introduction in 1989—160 horsepower/400 torque.

Owners Take Note

The most significant changes to the engines have occurred over the last ten years. In that time frame, there have been four legislation hurdles to overcome. The first hurdle was in 1991. From the graph you can see that NO_x was lowered the previous year from 10.7 to 6. Particulates were lowered from .60 to .25. The following changes were made to the engine effective 1/1/1991:

Changes To Control PM (1/1/1991)

Recall that the PM is predominately made up of unburned fuel and lube oil that gets past the rings. Much of the combustion technology swirl pattern/piston crown design that was previously discussed in relationship to NO_x is also critical in the reduction of PM. Combustion technology is simply making sure all the fuel and air that goes into the cylinder gets completely burned.

To understand oil control/ring to cylinder-bore technology, you've got to understand that the 1988 PM level of .6 g/bhp/hr is a dry engine. How “dry?” Here is an example: As a part of oil control testing, 1988 engines were directly coupled to electric motors and cycled through the rpm range. Fuel was not being injected into the engine, yet they could not meet the “futuristic” 1994 standard because of oil getting past the rings. Hey guys, we're not talking big clouds of blue smoke here; we're talking minute particles. The point: 1988 engines are “dry,” 1991 “dryer.”

P.S. Dry engines place heavy demands on the detergents and dispersants in your motor oil. The oil's detergent and dispersants must keep oil and soot that used to go out the exhaust in suspension until the appropriate oil change interval. Is your oil up to the task? See your Cummins distributor for Cummins' own Premium Blue and Premium Blue 2000 oils specifically designed for your engine.

Cylinder Block. As oil control is so critical for '91, you can see the need for cylinder bore to be concentric. Let's truly add a twist to our concentric definition. As you add all the components to the block and then put the engine in service, the block actually does twist. What you thought was a concentric cylinder bore is no longer concentric. The answer: an expensive honing method called "torque plate honing." A torque plate is fastened to the block to simulate the twisting movement of the engine. As the stress is being simulated, the final honing process takes place. Get your local machine shop to duplicate that type of finish! Strict concentricity from the bottom of the bore to the top of the bore is also maintained with torque plate honing.

Piston Rings. The top compression ring was changed to a lapped surface. The finish is analogous to the lapping of a valve to a cylinder head. Again, this process is done to control particulate matter by improving oil control (i.e. reducing oil consumption).

Changes To Control NO_x 1/1/1991

Charge Air Cooling. Also known as an intercooler, the air intake system was changed model mid-year '91 to coincide with the 1/1/91 emission legislation. Compressed air from the turbocharger is hot. Typical intake temperatures from a non intercooled—read from the turbocharger directly to the engine—are in the range of 300° F. Effective 1/1/91 the turbocharged air was routed through a cooling element (known as an intercooler), attached in front of the radiator, that uses forced or "charged" air as the vehicle is moving to cool the turbo air. Air intake temperature after charge air cooling is in the 120° range. As mentioned before, cooler in-cylinder temperatures help reduce NO_x formation.

Head Casting. To aid in complete combustion-/fuel atomization, the cylinder head intake ports were changed. The air intake swirl is controlled by the contour of the intake ports. The higher the swirl factors, the faster it spirals into the combustion chamber.

Piston/Piston Bowl. New piston bowl geometry was implemented to complement intake swirl change.

P.S. Understanding that the engines have to conform to the emissions standards as of January 1 of a given year, you can see why the early truck model '91 engines in Dodge pickups did not have the turbocharger intercooler as a part of the equipment build.

'94 - '98 TRUCKS



In the world of ever tightening exhaust emissions, long gone is this 12-valve engine with its mechanical P-7100 fuel pump.

1994-1997 And Early 1998 Horsepower Ratings

For model years 1994-95 the horsepower for the five-speed equipped trucks was 175 horsepower/420 torque. During these two years the rating for the automatic equipped trucks was 160/400. In model years '96 through '98 the horsepower rating for the five-speed equipped trucks was increased to 215 horsepower/440 torque. During these years the rating for the automatic equipped trucks was increased to 180/420. In '96 California engines were kept at the previous '94 and '95 specifications. Also in '96, exhaust gas recirculation was required for California. In '97 and '98 California engines were bumped to 180/420 in five-speed and automatic trim. All trucks in the '94 through '98 years had catalytic converters.

Owners Take Note

In 1994 the NO_x level was lowered from 6 to 5; Particulates were lowered from .25 to .10. The following changes were made to the engine:

Changes To Control PM (1/1/1994)

Catalytic Converter. Effective 1/1/94 Turbo Diesels had to be equipped with a catalytic converter. The diesel cat is different from an automotive cat. By definition catalysis is a "modification to increase the rate of a chemical reaction induced by a material unchanged chemically at the end of the reaction." In an automobile the reaction in the catalytic converter is aimed at reducing hydrocarbons, carbon monoxide and oxides of nitrogen into harmless carbon dioxide and water vapor. A diesel cat is designed to address the particulate component of diesel exhaust.

Low Sulfur Fuel. Remember this controversial topic? It is controversial only because the change to low sulfur fuel was greatly misunderstood. Let's revisit Issue 32 for a look at the low sulfur-myth as well as how important the 1/1/2007 lower sulfur fuel will be.

Starting 1/1/94 a lower standard of 500 parts per million (PPM) was adopted. The change down to 500 PPM was from a previous standard that was set at 5000 PPM (although the pre '94 average was 3000 PPM). The reduction in '94 to what has been named "low sulfur fuel" caused quite a controversy in the world of diesel engines. Many diesel fuel pumps developed seal leakage (our Turbo Diesel trucks were not affected to any degree), and the leakage led to many "Low sulfur fuel doesn't have any lubricity," and "When they took out the sulfur they took out the good stuff, curse the EPA," type stories. If an incorrect story gets repeated often enough it starts to sound like the truth. The following is the real story on low sulfur fuel.

Coinciding with the introduction of low sulfur fuel, a new set of diesel exhaust emission standards was legislated in 1994. One of the regulated exhaust items is particulate matter. Typically, particulates are unburned fuel and lube oil that escapes past the piston rings. Sulfur (sulfates) are a problem as they attach themselves to soot and hydrocarbon particles resulting from incomplete combustion and dramatically increase the total weight of the particulates emissions. Because the production of sulfates is directly proportional to the sulfur content of the fuel, the use of low sulfur fuels in cleaner burning engines helped the manufacturers meet the '94 emissions standards.

Diesel Particulate Emissions Makeup

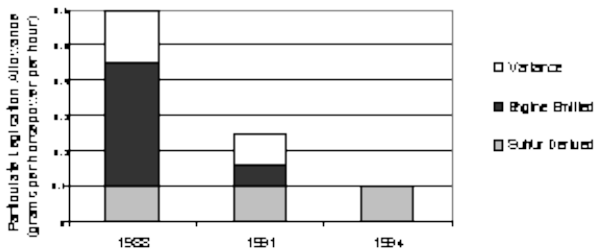

As you can see from the graph, low sulfur fuel was a necessity for 1994. Without low sulfur fuel, the diesel particulate output of 0.1 gram/hp/hr would result from fuel sulfur alone, allowing for no design variance or engine-emitted particulates.

We've established the need to remove the sulfur. Now let's address the incorrect truck stop myth about the value of sulfur as a lubricating element. The sulfur is removed by a process called hydrotreating. The *high temperature* hydrotreating process reduced the lubricity of the fuel! As an element, sulfur did not add to fuel lubricity.

I guess it's easy to see how sulfur was incorrectly linked to lubricity. Fact is, the fuel suppliers added a "lubricity package" to their fuels to compensate for the effects of hydrotreating.

Finally, when you hear the story that "sulfur is good" presented as factual data, you may want to excuse yourself from the conversation. Chances are the informant believes that Ford owns Cummins too.

With the background information out of the way, the petroleum industry has opposed the upcoming 1/1/07 legislative reduction to 15 PPM. By and large, the diesel

engine manufacturers supported the legislation, and ultra low sulfur fuel will be phased-in starting in June of '06.

Changes To Control NO_x 1/1/1994

Fuel Injection Pump. Prior to '94 only the 190 hp and up B engines utilized the Bosch P7100 injection fuel pump. Now the P7100 fuel pump is used on all on-highway applications. The P7100 pump is an in-line piston type fuel pump that replaced the Bosch VE rotary pump.

Why the change to the P7100? Higher pressure and more precise timing of fuel to the cylinder was necessary for '94. Remember the P7100 was already in use on the high horsepower engines. But for '94 the P7100 was actually redesigned again to increase the injection pressure up from the '91 levels.

Fuel Injection Timing. The Bosch P7100 fuel pump is capable of more precise fuel timing. A demonstrated use is to retard the fuel injection to later in the piston's travel to top dead center. Introducing the fuel later in the cycle keeps the in-cylinder temperature lower, resulting in lower NO_x production.

'98.5 – 2002 TRUCKS

In 1998, the NO_x level changed from 5 to 4; Particulates stayed the same at .10.

Understanding that the changes to the B engine are driven by the need to meet a lower NO_x standard for 1998, let's take a look at the 98.5 24-valve engine or ISB engine.

The ISB nomenclature is an acronym for Interact System, B-series engine. With an electronic fuel system, the Interact System gave the engine customer a wide range of information to aid in managing the operation of the vehicle. ISB engines were available in standard ratings from 175 to 230 hp with limited 250 and 275 hp figures for some RV and fire equipment markets. The Dodge ratings ended up at 235/460 for manual transmission trucks, 215/420 for automatic transmission trucks for '98. Later in year 2001 a high output rating of 245/505 was released and available only with the six-speed, NV5600 manual transmission. Also in the 2001 model year the rating was increased to 235/460 for the automatic transmission trucks and the five-speed trucks.

The Cummins 24-Valve—The Changes

Changes to the engine were well documented in the May '97 Issue of Diesel Progress magazine. To quote from Diesel Progress: "While many things remain—the bore and stroke, 5.9 liter displacement and overall engine dimensions are unchanged – there have been some rather significant changes, particularly in the upper structure of the engine. Among the changes are a new 24-valve head, new electronic fuel injection system, no-adjust overhead valve configuration."

Let's focus our attention on an explanation of the electronic fuel system and the new 24-valve cylinder head. Again from Diesel Progress:

"Perhaps the most significant change of all is the addition of the electronic control system. For the most part, engine electronic controls have primarily been a technology associated with larger engines.

"The electronic system directly controls the operation of the Bosch VP44 fuel pump, which has its own electronic module. The pump is a radial piston, distributor-style unit that is used to deliver fuel at high pressure to the six Bosch pencil-type injectors. Maximum injection pressure is approximately 20,000 psi.

"The injectors are vertically positioned at the center of the combustion chamber, a design made possible by the new 24-valve cylinder head. The new head design provides each cylinder with two intake and two exhaust ports and is engineered to provide a 10 percent improvement in airflow, resulting in better low end torque and response, higher power density and improved fuel consumption and emissions performance.

"The centered injector configuration has also led to changes in the piston design. The ISB engines still utilize single-piece aluminum pistons, but the bowl has been centered and the bowl geometry has been changed to accommodate centralized injection. 'As we center the bowl, it allows us to do some new things in terms of piston cooling,' said Cummins and Jim Trueblood, technical leader for the midrange program. 'We're also getting improved combustion through better air/fuel mixing. The ring temperatures are more uniform and we've found that to be very beneficial in terms of lowering lube oil consumption.

"Lower oil consumption is a key piece to reducing the lube SOF (soluble organic fraction), which is vital to reducing particulates. We've cut the lube SOF to half of the current product, which is a big part of the recipe that allows us to meet the emissions standards without a catalyst,' said Trueblood.

"The new head also allowed for the design of a no-adjust overhead assembly to drive valve actuation. 'No-adjust' is made possible by a pressure fed valve train assembly versus the previous engine's 'splash' design. Additionally, a nominal range for valve lash has been adapted for serviceability. The assembly uses the 'elephant's foot' design in the rocker and cross-head area, which is similar to what's used on some much larger engines. With the incorporation of stiffer valve springs, the system is fully compatible with exhaust brakes.

"Other features include larger water and oil pumps, which, along with more streamlined oil and water passages, provide for better cooling flow; a new two-piece exhaust manifold; a wastegated Holset HX35 turbocharger; an integral grid heater to improve cold starting; and a new top load fuel filter system designed by Cummins in cooperation with its subsidiary Fleetguard."

Other Changes

"A number of other structural changes have been made to the engine, several targeting noise reduction. The cast iron block has been redesigned and stiffened, while valve covers and oil pans have been isolated to reduce vibration. Double-skin front covers have been added, along with sound-attenuating side shields, pan covers and tappet covers as options."

Timing Is Everything

How often have we discussed the importance of fuel pump to engine timing, and thus the injection of fuel into the cylinder? To eliminate confusion, I'll not make reference to previous issues of the TDR. Let's simply look at timing references in this article. Under the "Changes to Control NO_x 1/1/91," note we talked about a change to retard the timing of the fuel pump to engine. Again in "Changes to Control NO_x 1/1/94," there was the change to the Bosch P7100 pump to provide "higher pressure and more precise timing of fuel to the cylinder." Also note a change in timing for the '94 model trucks "to keep the in-cylinder temperature lower resulting in lower NO_x production." Whether it be a discussion on the subject of emission control or a review of engine performance, "timing is everything."

The electronic control of the Bosch VP44 fuel pump is the key to the 24-valve's ability to meet the '98 emission standards. The VP44 electronic module/black box brings computer control to the engine. The computer control allows for infinitely variable timing.

Yes, timing is everything. The engine's fuel system uses inputs from the crankshaft speed, the position of the camshaft, the incremental angle of a timing sensor on the fuel pump, water temperature, intake manifold temperature, vehicle speed and load requirements to "manage" fuel injection timing and fuel rates—thus, performance and emissions.

THE NEW 2003-2004 HPCR CUMMINS ENGINE

First things first, the emission numbers: For 2004 the Federal NO_x will change from 4 to 2.4. The 2.4 number is actually a combination of NO_x and non-methyl hydrocarbons. California pulled up the NO_x standard and implemented a 3.0 number effective in late 2002. The California number parallels the Federal NO_x of 2.4 that forced on the six Consent Decree manufacturers (Cat, Mack, Detroit Diesel, Volvo, Navistar and Cummins) as they were required to meet the 2004 standard early. Their effective implementation date was 10/2002. The Dodge pickup engine was exempt from the 10/2002 early implementation (Issue 32, page 85). The particulate number of 1.0 stays the same for 2004.

Just as we have in reviewing the previous engines and their evolution, let's start with the all-important horsepower and torque ratings for the new high pressure, common rail (HPCR) engine. As you may have noted, power has been steadily increased over the years beginning with 160 horsepower and 400 lb-ft of torque in 1989 to the 305 horsepower and 555 lb-ft of torque with the new high output engine. The HO engine is available as an option and is

matched up to the NV5600, six-speed manual transmission or the newly introduced (January 2003 introduction) 48RE automatic transmission.

The standard engine is rated at 250 horsepower and 460 torque. This engine is matched to the NV4500, five-speed manual transmission or the 47 RE automatic transmission.

Trucks sold in California will get a 235 hp/460 torque (CARB) version of the engine. This lower rating was necessary because of a tighter nitrous oxide standard (three grams per brake horsepower hour) and was achieved through the use of an oxidation catalyst (similar to the one used on all 12-valve engines from '94 to early '98), engine control module programming, and smaller injectors.

TRANSMISSION	HORSEPOWER AND TORQUE RATINGS		
	California (CARB)	Federal (EPA)	
NV4500	235 hp @ 2,700 460 lb-ft @ 1,400	250 hp @ 2,900 460 lb-ft @ 1,400	
NV5600		305 hp @ 2,900 555 lb-ft @ 1,400	
47RE	235 hp @ 2,700 460 lb-ft @ 1,400	250 hp @ 2,900 460 lb-ft @ 1,400	
48RE (late availability)	235 hp @ 2,700 460 lb-ft @ 1,400	250 hp @ 2,900 305 hp @ 2,900 555 lb-ft @ 1,400	

HORSEPOWER CHANGES

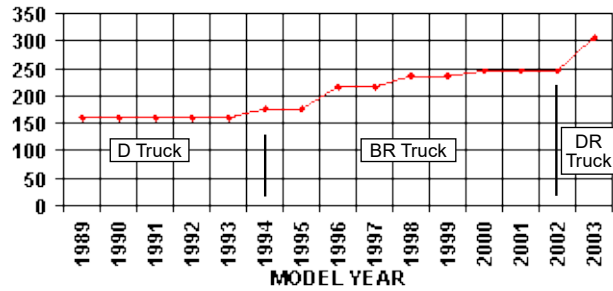

TORQUE CHANGES

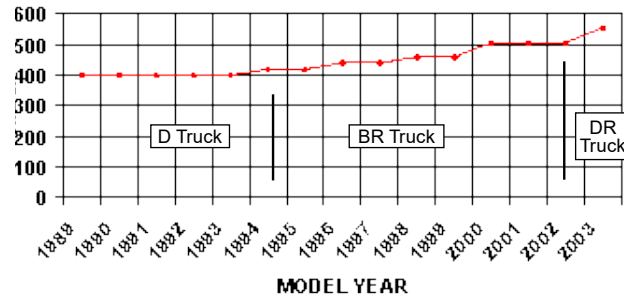

As an aside, often we receive the phone call, "My new '98 truck (or 2001, or 2003—pick your model year) just doesn't get the same fuel economy as my old, trusty '91 truck. What gives?" There are legitimate complaints that need mechanical attention, but the obvious answer to the smaller discrepancies lies in the progression of power. The new HO engine is rated 145 horsepower greater than the initial '89 through '93 engines. Torque on the HO engine is 155 lb-ft greater. The '98 24-valve engine boasted 55 horsepower and 20 lb-ft torque (automatic) or a 75 horsepower and 60 lb-ft torque (five-speed) increases. If you use the additional power, should the fuel economy stay the same?

Back to the subject at hand, the new HPCR engine. The Cummins HPCR engine is another evolutionary step in the 5.9 liter, B-series platform that was introduced back in 1983. However, two-thirds of the HPCR engine is new or redesigned. The lion's share of the new hardware has to do with the fuel injection system. The engine uses a HPCR fuel system from Bosch. Although new to us here in the United States, Cummins has used the HPCR fuel system in Europe for the past two years. This track history should eliminate product concerns that owners might have.

'03 Standard Output Versus 24-Valve Standard Output Rating

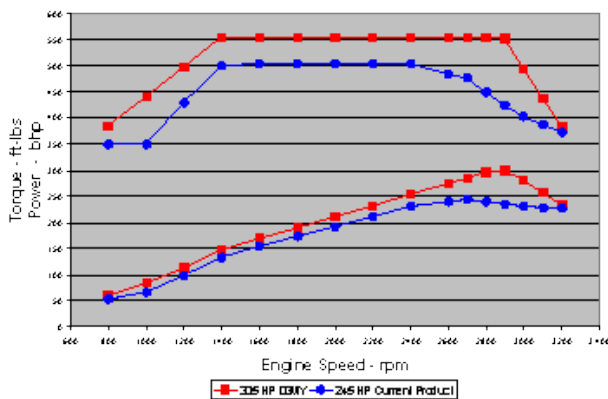

'03 High Output Versus 24-Valve High Output Rating

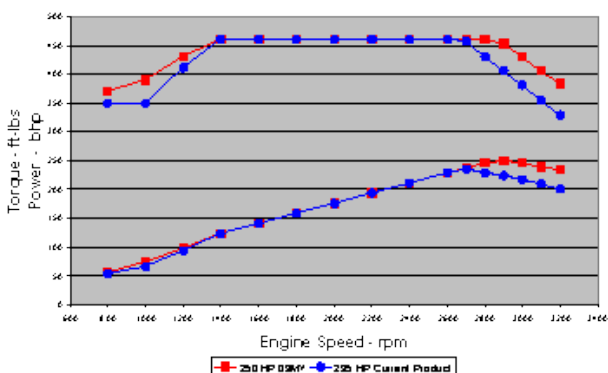

Parts Carryovers

Let's start the analysis by listing the carryover parts from the previous 5.9 liter engine. Purists will be pleased that the engine's bottom-end hardware; the crankshaft, connecting rod and bearing assemblies, are the same as the previous, proven, 24-valve engine. Other carry over parts include:

- Head bolts
- Water pump
- Oil pump
- Camshaft
- Valve train
- Critical fasteners (head, rod and flywheel bolts)

New Designs

As mentioned, the biggest change to the engine is the use of the Bosch HPCR fuel system. The system has rail pressure of 23,200 psi (1600 bar) on the high output engine. The change in the fuel system netted a reduction of 8-10 db of noise. Additionally, the ability to better control injection timing and pilot injection provides an extended rpm peak torque band over previous engines (200 rpm lower and higher). The lift/supply pump is located on the side of the motor right next to the fuel filter and is an all-new design supplied by Federal-Mogul.

Instead of an injection pump (previous VP44 electronic or P7100 and VE mechanical pumps) that sequences high-pressure fuel to injectors at the proper time, the new fuel pump supplies a common rail with high-pressure fuel, which is, in turn, fed to the individual injectors. The injectors deliver the pressurized fuel to the cylinders as the result of a signal from the engine control module, not as a result of a pulse of high pressure from the pump.

All in all, the HPCR fuel system brings the following attributes to the engine:

- Gear-driven fuel pump delivers high pressure fuel supply to a common rail
- Fuel delivery through electronically controlled unit injectors
- Multiple injection events (pilot, main, post injection)
- Higher injection pressures—up to 1600 Bar
- Timing, pressure and quantity less dependent on engine speed

As a result the owner can expect:

- Cleaner combustion
- Improved power and engine response
- Improved cold start capability
- Base fuel system to enable next emission step in January 2004
- Lower noise
- Lower vibration and harshness

Of course, the new fuel system drives changes throughout the engine. The cylinder head maintains a four-valve per cylinder design. However, the new cylinder head has induction hardened valve seats, on both intake and exhaust, to handle the higher temperatures and pressures.

The change to the HPCR fuel system drove several changes to the engine block. The block now incorporates sculpted side walls to stiffen the block. This change was necessary as the stiffer block is needed to help withstand the higher peak cylinder pressures needed for emissions control and power requirements. Additionally, it aids in noise reduction by absorbing noise. An engine's bedplate was also designed and added to the engine for less noise and greater durability.

Standard-output engines continue to use saddle jets located in the upper main bearing saddles to spray the connecting rods and the pistons.

HO engines use a new system that includes a component called a "J-jet" for each piston. The J-jet nozzle is bolted to the block and directs a stream of oil to the underside of the piston. HO pistons have a passageway to direct the flow of oil through the piston head to cool it. HO engines also have an exhaust manifold that is capable of higher exhaust temperatures.

Cummins has taken a measure to reduce the amount of dead space in the combustion chamber. The head gasket is now measured and matched (graded) based on block height and cylinder head thickness. During assembly a machine measures piston protrusion and, based on the measurement, a thick or thin headgasket is chosen for assembly. Get the picture that meeting emissions standards is serious business?



Underside of the HO piston. Note the passageway for oil to flow through the piston.



Underside of the standard piston.

Further, the HPCR fuel system necessitated changes to the engine's front gear train. New high contact-ratio spur gears result in quieter operation.

The turbo on all versions of the engine is an HY35 with a 9cm² exhaust housing. This turbo has been redesigned from previous HY35's. Exhaust exits the turbo at 3.5" and flows to a 3.5" muffler inlet. The exhaust is now a full 4" system from the muffler to the tail as opposed to the previous 3" system.

The turbo has an intake silencer to eliminate high frequency, blade pass noise. There is closer tolerance control of the turbo's critical components.

Specifications for turbocharger boost pressure are numbers that TDR members carefully watch. An engine that achieves its specified number is an engine that will deliver its advertised horsepower numbers. The wide open throttle boost specifications: standard engine, 22-24 psi; HO engine 25-26 psi.

OTHER CHANGES

External to the engine let's take a look at some of the other hardware changes.

In the area of accessory drive components, you will also notice that the power steering pump is now driven by the accessory drive belt instead of by a gear. The vacuum pump, which was previously combined with the power steering pump, is no longer used; however, it is available as a Mopar Accessory for trucks using an exhaust brake.

The radiator cooling fan used with the Cummins HPCR engine is quite a bit different than the fan used with previous engines. The fan still uses a viscous drive; now, however, the drive is actuated electronically by the engine control module. The controller looks at inputs from coolant, air intake, and transmission temperature sensors and the A/C status and then sends a pulse width modulated signal to the solenoid in the fan drive. The solenoid controls the viscous fluid to match fan speed to vehicle operating conditions.

The crankcase vent system has been a point of contention for many Turbo Diesel owners. To virtually eliminate the driveway-drip problem Cummins and Fleetguard have redesigned the crankcase vent system. Thankfully the crankcase vent (read: low pressure vaporized oil) is *not* routed to the engine's air intake system [like the new 6.0 liter Power Stroke (Issue 39, page 96) or the Volkswagen automotive diesel (Issue 38, page 28)]. I can tell you from firsthand experience with crankcase vent oil and exhaust gas recirculation with a Volkswagen passenger car that it is messy. The vent on the Cummins engine goes from the engine to an oil separator box on top of the valve cover then is vented to atmosphere.



The 2003 crankcase vent system. The white arrow shows the inlet from the crankcase to the filter assembly. The red arrow points to the outlet hose that vents to atmosphere.

Oil Change Interval

With concern I noted that the "Schedule A" oil change interval for the Turbo Diesel engine has been *doubled*, from the previous 7,500 miles to a 15,000 mile interval. This is new information that deserves further technical discussion.

Recall from Issue 35 that there will be a new specification for diesel engine oil, CI-4. This oil was introduced in late 2002. Excerpts from Issue 35's article on this oil follows:

"NO_x can be cut further by reducing combustion temperatures, and most engine builders have decided that cooled EGR is the most effective way. Small amounts of exhaust gas will be piped to the chambers to displace oxygen; less oxygen means cooler combustion. Before going to the cylinders, some of the exhaust gas's heat will be absorbed by the engine's coolant. Thus the term 'cooled EGR.'

"You will see diesels with cooled EGR by late next year, and by early 2004 most truck diesels will have it. These engines will run hotter and produce more soot than today's models. They'll also produce more acids that can attack internal parts. The new motor oil products will be formulated to take the greater loads and protect both new and existing diesels, according to petroleum engineers.

"Heat seems to be the biggest threat because it breaks down oil.

"There'll be a much greater heat load on oil,' says Michael Ragomo, technical advisor at ExxonMobil Lubricants & Petroleum Specialties Co., because heat from exhaust gas will be transferred to engine coolant, 'and when coolant gets hotter, oil gets hotter.'

"Soot levels in crankcase oil will rise to as much as 10 percent by volume."

Okay, the oil has to perform a more difficult task, yet the allowable oil change interval has been doubled? Time to consult with Cummins.

First, let's set the stage for oil discussion. For many readers the topic of lubricants is like discussing religion—no amount of logical or emotional appeal will change the mind of the individual or audience that you are talking to. Does that mean you are not open-minded to go to a 15K oil change? Certainly to change the oil more often would be on the safe side, so you're to be commended for diligent maintenance. Still, the Owner's Manual "Schedule A" (which is a light-duty cycle) and Cummins are saying that 15K is okay. What do you do?

The technical reason that allows owners of the new HPCR engine to go to a 15K interval is three-fold. Cummins confirms that the engine is very clean in its combustion event. The flow and swirl of the cylinder head, the unique piston bowl design, and the HPCR fuel system share equally in achieving the goal.

Don't think that Cummins released the 15,000 mile oil change interval without thoroughly researching the situation. In the past, soot analysis had to be done the old fashioned way via lube oil analysis. Now in the engine lab Cummins can check oil quality using a "soot cart." Oil is channeled outside the engine for optical evaluation of how dark the oil is based on the test time interval, test load factor and test fuel consumption. Within minutes the engineer knows how much soot was picked up by the oil. This data is the key to releasing the "Schedule A" oil change interval of 15,000 miles.

Second, the CI-4 lube oils are formulated to protect both new and existing diesels. We noted that there is anticipated higher heat load (oil oxidation) and higher soot levels. New lube oil formulas will include additional antioxidants to compensate for the higher temperatures and additional dispersants to hold the soot in suspension.

Third, consider Cummins' track record with oil changes in their big-rig engines. While it can be argued that the 15K oil change interval is marketing hype to be better than the competition, it is this writer's opinion that a marketing-only recommendation would be dangerous. Looking at the bigger picture, Cummins has allowed oil change intervals of 10,000 on their C8.3 liter engines, 15,000 on their M11 engines, and 15,000 on their N14 or ISX engines. Cummins obviously feels confident in the 15K light-duty, "Schedule A" oil change recommendation, or it would not be released.

We're now full circle, "What do you do?" Is the preceding nothing more than a discussion about religion? The 15K light-duty "schedule A" oil change recommendation has been endorsed and you now have additional information to consider.

Summary

Wow, that was a long lesson in the evolution of the B-series engine in the Dodge pickup application. Or, more appropriately, I should say that it was a long lesson in emission legislation numbers and their effect on diesel engine hardware. It is going to be interesting to follow the engine's development path as the year 2007 is not too far away.

I'm excited for Dodge and Cummins, as the new HPCR engine is proving to be their smoothest product introduction to date. In my one month of ownership, the power output and lack of diesel clatter, and fuel mileage are impressive. I look forward to bringing you more HPCR updates.

Robert Patton
TDR Staff

Notes:

'04.5 TO '07 HPCR ENGINE CHANGES

Further, let's discuss the changes made to the Cummins engine, focusing on the necessary changes made to the former 305 horsepower product in order to produce the new 325 horsepower engine that meets emissions requirements for all fifty states.

The primary means to control emissions on the new engine are inside the combustion chamber. Exhaust gas recirculation (EGR) is not used. This change represents a major advance from the interim approach, with use of EGR, taken in 2002 to meet federal EPA emissions regulations for the medium-duty truck market with the B-engine. The engine system becomes significantly simpler. Fifty-eight new part numbers were required to implement EGR as a part of the emissions strategy on the other versions of the B-series engine that Cummins sells to other customers. Only seven new emissions part numbers were needed for the new approach used on the Dodge 325/600-610 engine.

Starting 1/1/2004 a diesel oxidation catalyst (catalytic converter) was employed. The pilot injection/primary injection strategy has changed significantly. Formerly, a small pilot injection was followed by the larger injection event; at higher loads and above 2000 rpm, a single injection event would be used. In the new engine, two or three events are used. The pilot injection is larger, and when under power, a post-event is added. These events are part of the emissions and power strategy, as well as a means to noise reduction. The engine control module now contains 550 kilobytes of code for engine control, while the previous 305 horsepower HO engine used only 350 kilobytes.

The Cummins noise control strategy includes carry-over of the straight-cut gears from the previous HO engine.

A new cylinder head has revised ports with less swirl. High-cobalt stellite valve seats are used with high strength inconel valves. The forged steel connecting rods with cracked-cap technology are carried over from the 305 horsepower engine. These rods pass exactly the same strength and durability tests as the former, machined cap rods, while providing more rigidity than the former units. The exhaust manifold material and shape has been slightly revised for durability, and multi-layer gaskets are used between the manifold and head. The piston bowls are slightly more open. The cooling passages for the piston rings are carried over from the 305 horsepower HO engine.

For the '04.5 and '05 325/600-610 engines the turbocharger remains an HY-35, but with a new, larger compressor wheel and housing for increased air flow. The wastegate has an electronic controller to better match boost pressure to engine needs for optimized emissions control. The turbo shaft bearings have small oil reservoirs under them to improve oiling on cold start-up. The oil drain tube is flexible steel, replacing the former system of two rigid steel tubes connected by a hose with two worm-drive clamps. This oil drain and the new exhaust gaskets were developed as a result of their successful use in heavy duty engines.

2004.5-'07 Component Changes

The engine fan shroud is now engine mounted, with soft plastic seals to the radiator assembly. Mounting the shroud onto the engine allowed a tighter clearance to the fan blades for improved forced air flow and cooling. The area in front of the air cleaner box is shrouded with an air blocker so that hot air from the radiator and from recirculation inside the engine compartment cannot pass to the air cleaner. Dodge claims an improvement of 30 to 40 degrees in inlet air temperature. The fan clutch calibration is different, to reduce fan roar and to improve cooling. The turbocharger air intake system has been refined with a new "resonator," or air baffle. A hood insulator has been installed (absent in the past few years of Rams). With a new design catalytic converter, the exhaust system is now a full four inches in diameter throughout. With a manual transmission, the truck is configured to be compatible with the use of an exhaust brake. The intercooler is new, with higher flow.

New for 2005, the lift/supply fuel pump design has been changed. The previous electronic lift/supply fuel pump was located next to the fuel filter assembly. The pump has been relocated to the fuel tank where it pushes fuel to the engine rather than pulling fuel from the fuel tank.

For those trucks equipped with the 48RE automatic transmission there are subtle changes in other components. A pedal position sensor has replaced the throttle position sensor and the cruise control vacuum actuator has been removed, having been replaced as an integrated function of the ECM. There were additional changes to ECM programming to give the transmission a more aggressive lock-up schedule and to enhance the shift schedule.

Finally, for 2005 the intake air grid heater now uses a gasket that is electronically conductive. The conductive gasket allowed Cummins to eliminate the grid heater's ground strap.

Engine hardware—past, present, future: The proof of the HPCR's solid engine design will be shown in the heading covering the engine's product launch. Likely you noted that the changes to the engine in the past two years have been incremental. There are no anticipated changes for the '06 product.

ENGINE SOFTWARE: PAST, PRESENT, FUTURE

With TDR Issues 46 and 42 in hand, I carefully looked at the “TDRResource” column for Dodge technical service bulletins (TSBs) that would address programming or software changes to the engine control module (ECM). There was only one bulletin (found in Issue 46) and that TSB has been updated with the following TSB 18-037-04.

The single TSB that has been issued for the sales code “ETH” engines is indicative of a smooth product launch by Cummins. Point of clarification: ETH sales code applies to those engines that are known as high output. The engines that have a horsepower rating of 325 ('04.5 engines and early '05 models) are a part of the TSB's coverage.

Robert Patton
TDR Staff

CATEGORY 18 VEHICLE PERFORMANCE

TSB#	MODEL	SUBJECT/DESCRIPTION
18-037-04 9/27/04	'08 (DM) 4500/5500	<p><i>Fuel economy improvement, white smoke on start up, accuracy of fuel mileage in overhead console display.</i></p> <p>This bulletin applies to DR vehicles equipped with a 5.9L Cummins Turbo Diesel engine (sales code ETH), with an engine serial number 57130285 through and including 57246361; and the engine date of manufacture 12/10/2003 through and including 8/17/2004. The bulletin gives the dealership specific information for erasing and reprogramming the Cummins ECM with new software. The following enhancements are included with this software:</p> <ul style="list-style-type: none">• Improved fuel economy—A new ECM calibration has been developed which should provide customers an average fuel economy improvement of approximately 1 mpg.• Reduces white exhaust smoke on cold start at temperatures below 50°.• Improves accuracy of the fuel economy calculation in the overhead console display.

THE 6.7-LITER ENGINE INTRODUCTION

CUMMINS ENGINE ADVANCES AND THE DODGE CHASSIS CAB

by Joe Donnelly

At the 2006 May Madness event we were fortunate to have Dennis Hurst, Executive Director of Engineering at Cummins, Inc. as a featured guest speaker. Dennis gave us an excellent summary of the features and status of the new 6.7 liter Cummins engine that will be used in the new Dodge Chassis Cab. The Cummins Turbo Diesel accounts for 25% of all Ram pickup sales, and over 1.3 million Turbo Diesels have been sold. Other versions of the B-series engine are used in Freightliner and Ford medium duty trucks. Our engines are assembled at the Cummins Mid Range Engine Plant (CMEP) in Columbus, Indiana. The horsepower and torque ratings have increased from 160 horsepower and 400 ft-lb in '89 to 325 horsepower and 610 ft-lb in '05. He noted that the new EPA emissions standards had some impact on fuel economy, and that we could expect 17-20 mpg empty and 10-12 mpg loaded. He presented graphs showing that the Cummins gives one to three miles per gallon better than the competitors, the Ford 6.0-liter and Chevy 6.6-liter engines.

The 6.7-liter engine has a 107 mm bore and 124 mm stroke (versus 102 mm x 120 mm for the 5.9-liter engine). In inches, these measurements correspond to 4.21 x 4.88 inches versus 4.016 x 4.724 inches for the 5.9-liter engine. The engine is built on the architecture and concepts of the 5.9-liter engine that has been used from '03 to present. As before, the block and head are cast iron, with the block slightly modified for increased stiffness and noise reduction. The head has valve seat inserts on both intake and exhaust ports. High-strength, gallery cooled, aluminum pistons are used, similar to those used since '03 in the 5.9-liter high output engines. The emphasis with a commercial truck like a Chassis Cab is not the "horsepower race" but cost of ownership. Therefore, the engine is rated for a combination of power and economy of operation at 305 horsepower at 2900 rpm, and 610 ft-lb at 1600 rpm. This engine will have extensive electronic features, including power take-off (pto)-remote, pto-mobile pto; accelerator/throttle interlock (so the driver can't leave prematurely); remote accelerator/throttle; duty cycle monitor (present in today's 5.9-liter pickup engine also); switched maximum operating speed; and idle shut down (cool down time).

The new turbocharger has variable geometry with an innovative, proprietary sliding nozzle on the turbine side. The turbocharger is designed for increased capability at high altitudes. The variable geometry will give the turbocharger the ability to act as an exhaust brake. At 2000 rpm, this turbo gives 245 ft-lb braking effort versus 180 ft-lb for a typical aftermarket exhaust brake, a 36% increase.

The new engine will meet '07 EPA emissions requirements, and is designed to be long lasting and quiet, while retaining the good attributes of diesel sound. The long stroke aids in take-off with a load or trailer, whereas the competitor's V8 engines have shorter strokes and are subject to stalling easily on take-off.

From having the smallest engine of the three used in pickups, now Cummins will be the largest, compared to the 6.6-liter GM and new 6.4-liter Ford. Cummins has retained the design and construction features that give it the "million mile" legacy. It is still the only pickup/Chassis Cab engine that is medium duty with a 300,000 mile overhaul interval, versus the 100,000 mile interval suggested by the competition. The fuel system has evolved, with five fueling events per power cycle. There are two pilot injections, a main injection, and two auxiliary injections afterwards. The engine control module's central processor is twice as fast (80 versus 40 mHz), with 40% more flash memory, and 160 features versus 100 in the '06 computer. The '03 engine control module had 30 features. The new engine has a differently designed piston with a stiffer skirt and raised piston pin. The engine was designed for higher cylinder pressures and has a slightly re-designed head gasket for a different coolant flow pattern. You can expect to see cooled exhaust gas recirculation and particulate traps in the exhaust system to meet '07 EPA emission standards.



Diesel Particulate Filter

Cummins has responded to Dodge's request for lower noise and vibration with the new engine. The block's barrel skirts are re-contoured and the bores are siamesed (meaning the bores are cast together without water passages between them) and numerous small changes are incorporated such as turbo fin shape, and holes stamped in pulleys to reduce their noise. Some vibration, inherent to an inline six-cylinder engine, is removed with the engine mount system. And, in the case of the Mega Cab, a vibration that excited the larger cab was removed by fully machining the crankshaft counterweights.

The Dodge marketing strategy for the pickup truck provides the images of muscular and provocative styling, working and playing hard, and a combination of design, function, and emotion. With the Chassis Cab, the focus is on function. Chassis Cab buyers are typically small businesses, and two-thirds have ten or fewer vehicles. They want a dependable, functional truck that is easily adaptable to specific applications. Dodge will offer regular and Quad Cabs, gasoline (Hemi) and diesel engines.

Most Chassis Cabs are expected to have dual rear wheels. The Aisin six-speed automatic transmission will be featured. It has two tow settings, three low gears, dynamic interaction with the Cummins exhaust brake, a 35 horsepower power take off, and two overdrive choices for fuel economy.

Joe Donnelly
TDR Writer

WHAT'S UP WITH THE NEW 6.7-LITER ENGINE? by Robert Patton

In buying and selling the 6.7-liter Turbo Diesel, there is bad news and good news. For reasons well-known to everyone witnessing the steep rise in fuel prices, demand in the market for pickup trucks, and particularly for heavy-duty pickups, has taken a steep slide. But as a consequence there has never been a better time to buy.

In such a roiled market, there is a lot of uncertainty, but also much interest in what promises to be a unique pickup.

You've heard it from your friends, I'm sure, because as a TDR type you are the automotive and truck "authority" in your neighborhood. It goes with the badge on the grille of your Turbo Diesel.

Let's suppose a friend, let's call him Joe NewDiesel, puts it to you like this: "What's up with that new 6.7-liter engine in the famous Dodge-Cummins Turbo Diesel? I've read that it's a great new engine, but I've heard it has teething problems." Or he asks, "How can such a powerful engine really meet the tough emissions controls going into effect in 2010?" Maybe Joe NewDiesel follows that up with, "How can it achieve acceptable engine efficiency, considering the rising cost of fuel?"

If you are the neighborhood expert, or if you are the editor of the TDR, how do you get the story across, so your newcomer audience will understand that it makes sense to own one of those incredible 6.7-liter Turbo Diesels?

Just to make sure we get the facts right, we go to the TDR index and this is what you find:

- Issue 52 – Introduction of Cab and Chassis trucks with the 6.7 by Steve St. Laurent
- Issue 53 – Highlights of the 6.7 engine by Joe Donnelly
- Issue 54 – Sneak peak at the 6.7 engine in Cab and Chassis truck by Greg Whale
- Issue 55 – Introduction of a regular column chronicling the engine's ongoing progress
- Issue 56 – Exposé on how Cummins met the strict 2010 emissions standards
- Issue 57 – Joe Donnelly's detailed inspection of 6.7 engine specifications
- Issues 58 through 60 – Input and feedback from new owners in the field
- Issue 61 – A new regular feature, The Cummins' Column" with Cummins' answers.

We could hand Joe NewDiesel this bibliography, but Joe doesn't really want a pile of printed technical information. He just wants to know, thumbs-up or thumbs-down. At most he wants us to summarize the facts for him.



Besides a thumbs-up/thumbs-down answer, we believe that Joe NewDiesel must also be apprised of the background that led to the introduction of the 6.7 engine. So what exactly do you say, Mister Editor or Mister TDR Expert?

It's a challenge, but here is how it might play out between you or me and Joe NewDiesel. We decide to begin by spotlighting the most impressive developments in the diesel industry in recent years. We tell Mr. NewDiesel that with the new 6.7-liter engine, Cummins has achieved a nearly unbelievable reduction of 90% (that's right 90%, you emphasize) in both particulate matter and oxides of nitrogen from the already strict standards implemented in 2004.

Joe NewDiesel's reaction, "Ho hum ... everyone has to do it."

"No, Joe," we counter; "other diesel engine manufacturers are still scrambling to qualify for 2010, while the Cummins engine is so clean that it has put the 2010 standards behind it, and in so doing leaves the competition behind."

Joe NewDiesel affects nonchalance: "So, what's that mean to me?"

Apparently Mr. NewDiesel is not as wrapped-up in this emissions thing as we are. Remember he just wants a thumbs-up or thumbs-down. But we are not letting him off that easy; we are providing context. We tell him, "So, unlike the yo-yo changes that we have had to endure every 3 to 4 years, the 6.7 engine will be good until the next set of emissions legislation in 2013.

"Additionally, consider that the 6.7 engine offers a rock-solid engine-design platform that allows Dodge to ease into the next generation Ram, to further the stable Dodge/Cummins relationship, and continue to keep this truck at the head of the pack.

"It is really uncertain what will happen with the Ford and Navistar relationship," you advise Joe NewDiesel; and therefore you suggest, "You clearly would not want a Ford truck." You explain that "the Duramax diesel engine in GM products will be totally revamped to meet the 2010 emissions standards. You'll not want to be the first on the block to own that engine either. Rumor has it that they'll offer a V-6 for 1500 trucks and a V-8 for their 2500/3500 trucks. The engine will be a radical departure from the normal intake-in-the-center and exhaust-out-of-the-side Vee configuration."

Joe NewDiesel affects a yawn. (This guy is difficult to bowl over.)

To keep him engaged, we make a strategic concession: the new engine is not perfect. "Yes, Mr. NewDiesel, there have been what you've called 'teething problems'. Admittedly, vehicles in early production runs were plagued by a flurry of engine-computer fault codes and the newly designed diesel particulate filter had initial problems in regeneration cycles, and turbochargers that were not prepared to deal with an overburden of soot. In spite of these shake-down complaints, this engine can safely be pronounced as Excellent."

"Excellent?" quizzes Joe NewDiesel with raised eyebrow.

"Yes, excellent," we maintain, settling back for some more-specific technical stuff. Finally Joe shows his interest and is prepared to listen to our background facts. We pull out the stops. From here out, it's not conversation, it's factual recitation.

In April the 6.7-liter engine earned the PACE Award winner status after an extensive review by an independent panel of judges, a comprehensive written application, and a site visit. The 14th annual award was presented in a ceremony in Detroit, Michigan, by [Automotive News](#) and co-sponsors Microsoft, SAP, and Transportation Research Center Inc. So, to have the PACE Award given to Cummins means the automotive community recognizes that Cummins is the first to meet 2010 emissions (I'm counting, that gem of a fact has been emphasized three times) by using a NO_x absorber catalyst (NAC) thereby eliminating the necessary scramble that others will face in 2010.

Nonetheless, as we've noted, this engine launch is not as trouble-free as the previous '03-'07 5.9-liter engine, which received a resounding thumbs-up from the beginning, while the comparable Ford 6.0-liter engine received a big disappointing thumbs-down. At that time the GM Duramax got a solid thumbs up.

But NewDiesel isn't interested in history— he maintains that he is not in the market for a used truck. To add depth to these facts, we identify the Ford and GM diesel web sites where he can scrutinize the laundry list of problems that they are having with their '07.5 and newer engines. Joe understands our point. He accept the warrant of Cummins' reputation, and he feels safe in the support of TDR members to keep him in the know. He goes straight to everybody's bottom line—the big question today—"How's the fuel mileage on the new 6.7?"

Mr. NewDiesel is not being coy now: he has his note pad out. And we don't spare the details. At this point, I proceed unabashedly as editor, drawing technical information from the resources of the TDR to explain the operation and energy dynamics of the new engine as it compares to earlier Turbo Diesel engines.

My basis for comparison:

- 110,000 miles behind the wheel of a '03 2500, Quad Cab, short box, 47RE automatic with 3.54 gearing ($.69 \times 3.54 = 2.44$ overall top gear) and two-wheel drive.
- 25,000 miles behind the wheel of a '07.5, 3500, Mega Cab, long box, 68RFE automatic with 3.73 gearing ($.63 \times 3.73 = 2.34$ overall top gear) and two-wheel drive.

Engine Data:

- The '03 5.9-liter engine was rated at 235hp/460 torque. It had a TST performance module set on level 3 which provided about 40 more horsepower/60 torque (275hp/520tq). Mileage wise, the TST module modified the timing of the fuel injection. Injection timing changes can improve fuel economy, but often do so at the expense of increased exhaust emissions. (Also note: Advancing the injection timing will result in higher peak cylinder pressures and can overstress the power cylinder, cylinder head and block structure, and engine rod and main bearings, depending on the amount of injection timing change.)
- The '07.5 6.7-liter engine is rated at 350 horsepower/650 torque. No modifications have been made to this engine.

Without changing my driving habits:

- Pulling 12,000 pound/30ft car hauler at 70 mph
12.0mpg with the '03
10.0mpg with the '07.5
- Around town (using a light left foot)
16-17.5mpg with the '03
13.5-15.0mpg with the '07.5
- Unloaded freeway travel (level ground) at 75 mph
19-20mpg with the '03
17-18mpg with the '07.5

Should I have believe that the '07.5 truck would be as frugal as the '03 truck? Sure, why not have unrealistic expectations. But seriously, the '07.5 is a dually truck (bigger aerodynamic block) and is a Mega Cab/Long Box and, I'm guessing, weighs 1,200 pounds (17%) more than the '03. Likewise the '07.5 engine offers 75 horsepower and 130 torque over the '03. Do I use that power? You bet. It would be unrealistic to expect the same mileage results.

Observations:

Back in May of '06, Cummins' Executive Engineer of the Cummins Chrysler Program attended the May Madness TDR event. In a presentation about the upcoming '07.5 production of the 6.7-liter engine, he noted "new EPA emissions standards had some impact on fuel economy, and that we could expect 17-20mpg empty and 10-12mpg loaded. Graphs were presented showing that the Cummins gives one to three miles-per-gallon better than the competitors, the Ford 6.0-liter and Chevy 6.6-liter engines."

As I look at my personal miles-per-gallon, the numbers are very close to those set forth in the presentation.

With the current price of diesel, fuel economy has become more important to many of you. So, what can you do?

- *Idle time decreases fuel economy. You are burning fuel while going nowhere, so you get 0 MPG.*
- *Driving style can have a big impact on fuel economy. Accelerate at a moderate pace whenever possible.*
- *Higher speeds burn more fuel. Lowering your speed, especially on the highway, will improve fuel economy.*

The 6.7-liter Turbo Diesel Owner's DVD provides some good operating tips for better fuel economy. It is available for viewing at the TDR's web site www.tdr1.com; site features; TDR TV.

Regardless of my data or the expectations of the factory-guy, I do have some test data from Dodge that compares our Cab and Chassis/work trucks to the Ford 6.4-liter (their new for '07.5 product) and the Chevy 6.6-liter engine (for '07.5).

The data comes from my notes taken at the National Truck Equipment Association meeting this past spring in Atlanta, Georgia. I attended a presentation by Dodge discussing the Cab and Chassis trucks. They had commissioned an outside testing organization to conduct SAE fuel consumption testing. The trucks used were the Dodge 5500, Ford 550 and Kodiak 5500 and the trucks were ballasted to a weight of 15,950 pounds; equivalent options and identical box configurations. The Dodge proved to be 14% more fuel efficient than the Ford, 23% more efficient than the Chevy. My apologies, as I can't recall from my notes the mpg numbers from the test.

Moving right along now, Joe NewDiesel presses for a response to the second part of his initial request: that we provide him a coherent summary of facts on the engine's hardware, a sort of digest on parts and design.

It seems to me that the most efficient way to present this information is to describe the parts and hardware of the new 6.7-liter engine in terms of how they differs from those in the previous Cummins engine, working with help from technical personnel at Cummins, and drawing on resources as editor of this magazine, including data from previous TDR articles about how the exhaust after-treatment components operate.

THE ENGINE'S HARDWARE

Cylinder Block and Hardware

The 6.7-liter engine has a 107mm bore and 124mm stroke (versus 102mm × 120mm for the 5.9-liter engine). In inches, these measurements correspond to 4.21 × 4.88 inches versus 4.016 × 4.724 inches for the 5.9-liter engine. See the chart below for a comparison of the later 5.9-liter manual transmission rating (highest output 5.9-liter for Dodge Ram truck) to the 6.7-liter pickup truck automatic transmission rating (highest output 6.7-liter for Dodge Ram truck).

	6.7L	5.9L
Displacement	6.7L (409 C.I.D.)	5.9L (359 C.I.D.)
Bore	107mm	102mm
Stroke	124mm	120mm
Max. HP	350 hp @ 3013 RPM	325 hp @ 2900 RPM
Max. Torque	650 lb-ft @ 1500-2800 PRM	610 lb-ft @ 1600 RPM
Turbo	Holset Variable Geometry	Holset Wastegate
Fuel System	Bosch HPCR	Bosch HPCR

To accommodate the larger bore, the cylinder walls are "siamesed" or cast together with vertical coolant passages drilled between them. During development of this engine block, high priority was assigned to considerations of high strength, proper coolant flow, achieving perfectly round cylinder bores, and long-term durability. The engine is built on the architecture and concepts of the 5.9-liter engine used from '03 to the present. As I have noted, the block and head are cast iron, with the block slightly modified for increased stiffness and noise reduction. The skirt is re-contoured for improved stiffness and reduced transmission of noise. Coolant passages were optimized for coolant flow with the siamesed bores, with cross-drillings for coolant flow between cylinders.

Rod Bearings: The lower bearing stayed the same. The upper rod bearing is a new bi-metal design.

Crankshaft: Increased stroke for the 24mm increase in displacement. Counterweight profiles were modified for reduced noise, vibration, and harshness. A simple design change to machined counterweights versus "as forged" made a significant improvement in the linear vibration levels of the engine in vehicle.

Block Stiffener Plate: Used on all engines to strengthen block and reduce noise.

Front Crankshaft Seal: Updated lip style that utilizes a wear sleeve as needed for service repairs.

Connecting Rods: The rods are still of the fracture split design but because of weight differences, they are not backward compatible. The benefit of the fracture split design is a joint between the rod and the cap that is perfectly matched and more resistant to slip.

Oil Pump: The mounting bore in the block for the oil pump was reduced in size to strengthen the block.

Fuel Pump: The pressure has been increased from 1600 bar (23,200psi) to 1800 bar (26,100psi).

Grid Heater: The grid heater is now incorporated into the intake plate. If the grid fails, the entire plate will have to be replaced. With exhaust gas recirculation, the grid heater has a self-cleaning mode to prevent excessive build-up. Conditions for self cleaning are as follows:—the engine has been running for 30 seconds, vehicle speed is less than 18mph, and intake temperature is greater than 66°.

The engine also has a closed crankcase ventilation system developed by Cummins Filtration. The system incorporates a coalescing filter that captures oil mist and returns it to the crankcase. The filter requires service after approximately 60,000 miles.

Turbocharger

The turbocharger is now a proprietary Holset variable-geometry design. The sliding nozzle ring in the turbine housing (exhaust side) allows for continuously variable air flow and boost pressure. It works with the cooled exhaust gas recirculation (EGR) system and aftertreatment system to help reduce exhaust emissions. What you will feel from the driver's seat is better response and better altitude capability. The new turbocharger also provides an integrated exhaust brake. The braking performance is better than the optional exhaust brake on a 5.9-liter, and it now comes standard with every Cummins 6.7-liter powered Dodge Ram.

Cylinder Head, Pistons and Hardware

The cylinder head has valve seat inserts on both intake and exhaust ports. High strength, gallery-cooled aluminum pistons are used, similar to those used since '03 in the 5.9-liter high output engines. The crankshaft counterweight profiles have been changed, reducing noise, vibration, and harshness (NVH). These considerations are important for penetrating the "mainstream" marketplace, where owners are less diesel enthusiasts than seekers of smooth, quiet, powerful, and luxurious pickup trucks.

Valve Lash: The valve lash settings are the same as used on the later 5.9's, at 0.010" intake and 0.026" exhaust.

Pistons: The piston pin is offset for reduction in idle noise.

Piston Cooling: Targeted piston cooling nozzles are used on all ratings, providing oil flow to the piston cooling galleries. The benefit of gallery-cooled pistons is better durability because of decreased piston temperature.

Headgasket: Still graded? Pistons graded? There is only one service headgasket for the 6.7. It is acceptable for all repairs as long as the head, block, and piston are within service limits.

The Exhaust Aftertreatment

To get an overview of the exhaust aftertreatment components I went back to Issue 56 and information quoted from the trade publication *Diesel Progress*. [Note that the following descriptions apply primarily to the aftertreatment system in the pickup. The chassis cab aftertreatment system omits the NO_x Adsorber (NAC), keeping the DOC and DPF which are both housed in a single canister under the truck.] From our Issue 56: "The Aftertreatment system is a three-section unit. All three aftertreatment sections have their own active regeneration schedules, and the engine ECM controls the regeneration cycles.

"The system begins with a close-coupled catalyst—essentially a conventional diesel oxidation catalyst (DOC) incorporating a metallic substrate—mounted to a short downpipe just off the back of the turbocharger. A short distance behind and below the close-coupled catalyst is the NO_x adsorber unit, which is followed by a particulate filter. Both the NO_x adsorber and diesel particulate filter (DPF) use ceramic substrates.



These components were taken from a Cummins test vehicle.

1. diesel oxidation catalyst (DOC)
2. NO_x adsorber catalyst (NAC)
3. diesel particulate filter (DPF)

"The next part of the system is the NO_x adsorber catalyst, or NAC. The NAC has been cited by the EPA as a promising technology and as providing a possible key in future rule-making to solve the daunting nitrous oxide puzzle.

"A NO_x adsorber resembles a conventional catalyst, incorporating a catalytic substrate through which diesel exhaust is directed. Then the NO_x molecules are collected and held—'adsorbed'—onto the surface of the substrate, removing them from the exhaust stream. When the surface area of the substrate is full, the adsorber is regenerated with heat used to chemically change the NO_x into more benign gases, mostly nitrogen and oxygen.

"The NO_x adsorber is regenerated every few minutes at approximately 600° to 800°F and the process takes about three to five seconds. The NO_x adsorber will also, over time, collect sulfur from the fuel, which will gradually reduce its effectiveness. So depending on how much fuel is burned—typically every two tankfuls,, a separate regeneration cycle is initiated to remove the sulfur. The use of high sulfur fuel is not allowed because it results in a high degradation rate of this catalyst.

"The third part of the aftertreatment is the diesel particulate filter (DPF). The DPF is regenerated when differential pressure sensors in the exhaust system detect a specified amount of loading on the substrate. Unlike the PM filter systems used on heavy-duty applications, there is no ash cleaning required, and the PM filter—like the NO_x adsorber and close-coupled catalyst—is rated for the life of the vehicle.



The "in" and "out" sides of the DPF.



EGT, oxygen and pressure sensors monitor the need for regeneration of the NAC and DPF.

"In another departure from the heavy-duty side, all of the hydrocarbon dosing (diesel fuel) needed to raise the temperature for the various aftertreatment regenerations is handled by the fuel injection system rather than a separate injection system.

"It took some time and a lot of work to integrate the control system,' said Jim Fier, technical project leader. 'Some of the fuel we use to light the catalyst is partially burned, and any time you burn fuel, you produce power. If this were not the case, you would feel that extra fuel as power. With both the air handling and the fueling, we had to adjust those various pulses in order to keep the power balance and the torque balance as we go in and do the regenerations.'

"Cummins itself engineered the entire aftertreatment system, right down to specifying the washcoat on the catalyst bricks; and the system was assembled by Tenneco, which does aftertreatment system packaging for many segments of DaimlerChrysler."

So, how does the DPF regeneration process operate? When the ECM determines that regeneration is needed, fuel dosing brings the temperature above 950°F. Under normal conditions the injectors pulse three times for a given firing event. Pilot occurs just before top dead center, main injection at TDC and post when the piston is traveling down on the power stroke. If fuel dosing is necessary for increase in EGTs, there can be two more fuel injection events, very late on the power stroke then and during the exhaust stroke.

Active regeneration is more difficult if the vehicle is operating in a very low speed drive cycle, and will not occur with the transmission in Park or with the Parking Brake set. Improvements in regeneration with later calibrations have made regenerations more effective in all drive cycles, including in-town drive cycles.

Later calibrations also have improvements in operation at idle, making the system much more tolerant to idle time than it was previously. These changes dramatically reduce the amount of soot produced when idling is necessary, and allow the system to reduce the level of soot in the DPF under conditions of more extended idle. However, care must still be taken to watch for DPF messages on the overhead console (EVIC) signaling a need for a change in drive cycle to enable regeneration. With the latest calibrations, idle-up should not be used in an attempt to help the aftertreatment system during extended idle, as has been common with the 6.7. The new idle modes are more effective if idle-up is NOT used.

Conclusion

Some or all of the foregoing text should answer the probing question posed by "Joe NewDiesel" and others of his kind: "What's up with the new 6.7-liter engine?"

Should you have questions regarding the 6.7-liter Cummins engine I would like to forward them on your behalf to our helpful contacts at Cummins Inc. You can submit your inquiry to me at rpatton@ix.netcom.com (other contact information on page 138) and I will try to coordinate a response(s) for Issue 63

Robert Patton
TDR Staff

Notes on exhaust system regeneration:

The ECM continuously monitors the level of particulates (soot) and other substances in the exhaust aftertreatment system. As needed, the ECM triggers a regeneration to remove them. This is completely transparent to the driver. There are no indicators on the instrument cluster or EVIC, and there is no difference in sound or feel of the engine. In other words, when things are operating as normal, as they do for the majority of owners, you will not know that a regeneration is needed or in-process.

In rare cases, typically due to difficult drive cycles, a regeneration may not be possible. In those cases, you may see a message on the overhead console (EVIC) regarding the aftertreatment system, stating either 'CATALYST FULL' or 'EXHAUST SYSTEM REGENERATION REQUIRED NOW', depending on the level of software. As long as the percent-full message is less than 100%, the system can complete a regeneration if you change your drive cycle to allow it to happen. The most effective drive cycle for regeneration is highway cruise. Some trucks, depending on the level of software, will display 'REGENERATION IN PROCESS' if your drive cycle has changed such that regeneration has been started. Note that this message will occur only after the system has gotten full enough to display the 'EXHAUST SYSTEM REGENERATION REQUIRED NOW', meaning you will not see it on every regeneration.

A visit to your dealer is necessary only if a message regarding the exhaust aftertreatment system reading 'SEE DEALER' or 'SERVICE REQD' is displayed on the EVIC. In that case, getting the truck to the dealer sooner, rather than later, may prevent further damage to the system.

The 6.7-liter Turbo Diesel Owner's DVD provides additional detail on the aftertreatment system and operating tips. Watch it for more information.

ENGINE RATINGS 1989-2015

RATINGS: PAST, PRESENT, FUTURE

Publishing the past and present ratings for your Turbo Diesel is as easy as making a chart. The horsepower and torque numbers make good copy, but you'll note from the chart that there are two additional columns, "CPL and Comments."

The comments column is self explanatory.

CPL is a Cummins abbreviation that stands for "control parts list." The CPL provides a comprehensive breakdown of performance hardware, i.e. pistons, turbo, camshaft, injectors, and fuel pump that were used in the engine build. The CPL number along with the Cummins engine serial number will help your Cummins parts professional should you need engine hardware.

Model Year	HP@RPM	Torque @RPM	CPL	Transmission	Comments		
1989-1991 Non-Intercooled	160@2500	400@1600	804	Automatic and Manual	One CPL for both transmissions over a three-year production run.		
1991.5-1993 Intercooled	160@2500	400@1600	1351	Automatic and Manual	21mm turbo housing		
			1579		18mm turbo housing and LDA		
1994-1995	160@2500	400@1600	1815	Automatic	No Catalyst CPL (pre 1/1/94)		
			1549		DOC		
			1959		DOC		
			1968		DOC		
	175@2500	420@1600	1816	Manual	No Catalyst CPL (pre 1/1/94)		
			1550		DOC		
1994-1998 5.9L 12V	180@2500	420@1600	2022	Automatic	Initial 1996 production – DOC		
			2174		Timing change – DOC		
			215@2600	440@1600	1863	Automatic and Manual	CARB w/EGR – DOC
					2308		CARB timing change – DOC
	215@2600	440@1600	2023	Manual	Initial 1996 production – DOC		
			2175		Timing change – DOC		
1998.5 5.9L 24V	215@2700	420@1600	2098, 2513	Automatic	EPA certification		
			2280, 2515		CARB certification		
	235@2700	460@1600	2024, 2512	Manual	EPA certification		
			2279, 2514		CARB certification		
1999 5.9L	215@2700	420@1600	2617	Automatic	EPA certification		
			2619		CARB certification		
	235@2700	460@1600	2616	Manual	EPA certification		
			2618		CARB certification		
2000 ISB	215@2700	420@1600	2660	Automatic	EPA certification		
			2661		CARB certification		
	235@2700	460@1600	2662	Manual	EPA certification		
			2663		CARB certification		

DOC = diesel oxidation catalyst NAC = NO_x absorption catalyst DPF = diesel particulate filter SCR = selective catalyst reduction (urea)

Model Year	HP@RPM	Torque @RPM	CPL	Transmission	Comments
2001 ISB	235@2700	460@1600	2865, 2902	Automatic	EPA certification
			2866, 2903		CARB certification
			2496, 2904	5 Manual	EPA certification
			2497, 2905		CARB certification
	245@2700	505@1600	2415, 2906	6 Manual	EPA certification
			2495, 2907		CARB certification
2002 ISB	235@2700	460@1600	8030	Automatic	EPA certification
			8031		CARB certification
			8032	5 Manual	EPA certification
			8033		CARB certification
	245@2700	505@1600	8034	6 Manual	EPA certification
			8035		CARB certification
2003 5.9L HPCR	235@2700	460@1400	8216	47RE Automatic	CARB certification – DOC
			8224	5 Manual	
	250@2900	460@1400	2624	47RE Automatic	EPA certification
			8223	5 Manual	
	305@2900	555@1400	2998	6 Manual	EPA certification
	2003.5 5.9L HPCR	235@2700	460@1400	8410	47RE Automatic
8412				5 Manual	
250@2900		460@1400	8212	47RE Automatic	EPA certification
			8226	5 Manual	
305@2900		555@1400	8228	6 Manual	EPA certification
			8213	47RE Automatic	EPA certification—2003.5
2004 5.9L HPCR	235@2700	460@1400	8412	47RE Automatic	CARB certification – DOC
			8412	6 Manual	
	305@2900	555@1400	8213	47RE Automatic	EPA certification
			8228	6 Manual	
2004.5 5.9L HPCR	325@2900	600@1600	8350	6 Manual	EPA certification – DOC
			8351		CARB certification – DOC
			8346	48RE Automatic	EPA certification – DOC
			8347		CARB certification – DOC
2005 5.9L HPCR	325@2900	610@1600	8423	6 Manual	EPA certification – DOC
			8424		CARB certification – DOC
			8421	48RE Automatic	EPA certification – DOC
			8422		CARB certification – DOC
2006 5.9L HPCR	325@2900	610@1600	8348	6 Manual	EPA certification – DOC
			8349		CARB certification – DOC
			8344	48RE Automatic	EPA certification – DOC
			8345		CARB certification – DOC

DOC = diesel oxidation catalyst NAC = NO_x absorption catalyst DPF = diesel particulate filter SCR = selective catalyst reduction (urea)

Model Year	HP@RPM	Torque@RPM	CPL	Transmission	Comments
2007 5.9L HPCR	325@2900	610@1600	1091	6 Manual	EPA certification – DOC
			1095		CARB certification – DOC
			1000	48RE Automatic	EPA certification – DOC
			1083		CARB certification – DOC
2007.5 6.7L HPCR Pickup	350@3000	610@1600	8232	6 Manual	EPA certification – DOC/NAC/DPF
			8234		CARB certification – DOC/NAC/DPF
			8230	68RE Automatic	EPA certification – DOC/NAC/DPF
			8231		CARB certification – DOC/NAC/DPF
2007.5 6.7L HPCR Cab/Chassis	350@3000	610@1600	8232	6 Manual	EPA - DOC/NAC/DPF
			1264		CARB - DOC/NAC/DPF
		650@1600	2885	Aisin Automatic	EPA - DOC/NAC/DPF
			1257		CARB - DOC/NAC/DPF
2008 6.7L HPCR Pickup	350@3000	610@1600	1489	6 Manual	All States - DOC/NAC/DPF
		650@1600	1490	68RFE Automatic	All States - DOC/NAC/DPF
2008 6.7L HPCR Cab/Chassis	305@2900	610@1600	8235	6 Manual	All States - DOC/DPF
			2886	Aisin Automatic	All States - DOC/DPF
2009 6.7 HPCR Pickup	350@3000	610@1600	1489	6 Manual	All States - DOC/NAC/DPF
		650@1600	1490	68RFE Automatic	All States - DOC/NAC/DPF
2009 6.7L HPCR 3500 Cab/Chassis	305@2900	610@1600	2780	6 Manual	All States - DOC/DPF
			2775	Aisin Auto	All States - DOC/DPF
2009 6.7L HPCR 4500-5500 Cab/Chassis	305@2900	610@1600	2779	6 Manual	All States - DOC/DPF
			2774	Aisin Auto	All States - DOC/DPF
2010 6.7L HPCR Pickup	350@3000	610@1600		6 Manual	All States - DOC/NAC/DPF
		650@1600		68RFE Auto	All States - DOC/NAC/DPF
2010 6.7L HPCR 3500 Cab/Chassis	305@2900	610@1600		6 Manual	All States
				Aisin Auto	All States
2010 6.7L HPCR 4500-5500 Cab/Chassis	305@2900	610@1600		6 Manual	All States
				Aisin Auto	All States

DOC = diesel oxidation catalyst NAC = NO_x absorption catalyst DPF = diesel particulate filter SCR = selective catalyst reduction (urea)

Model Year	HP@RPM	Torque@RPM	CPL	Transmission	Comments
2011 6.7L HPCR Pickup	350@3000	610@1400		Manual	All States - DOC/NAC/DPF
		650@1600		68RFE Auto	All States - DOC/NAC/DPF
2011.5 6.7L HPCR Pickup (HO)	350@3000	800@1600		68RFE Auto	All States - DOC/NAC/DPF
2011 6.7L HPCR 3500 Cab/Chassis	305@2900	610@1600		Manual	All States SCR System
				Aisin Auto	All States SCR System
2012 6.7L HPCR Pickup	350@3000	610@1400		Manual	All States DOC/NAC/DPF
		800@1600		68RFE Auto	
2012 Cab/Chassis	305@2900	610@1600		Manual	All States SCR System
				Aisin Auto	
2013 6.7L HPCR Pickup	350@2800	660@1400		Manual	All States SCR System
	370@2800	800@1600		68RFE Automatic	
	385@2800 HO	850@1700		Aisin Automatic	
2013 Cab/Chassis	320@2800	650@1600		Manual	All States SCR System
	325@2400	750@1600		Aisin Automatic	
2014 6.7L HPCR Pickup	350@2800	660@1400		Manual	All States SCR System
	370@2800	800@1600		68RFE Automatic	
	385@2800 HO	850@1700		Aisin Automatic	
2014 Cab/Chassis	320@2800	650@1600		Manual	All States SCR System
	325@2400	750@1600		Aisin Automatic	
2015 6.7L HPCR Pickup	350@2800	660@1400		Manual	All States SCR System
	370@2800	800@1600		68RFE Automatic	
	385@2800 HO	865@1700		Aisin Automatic	

DOC = diesel oxidation catalyst NAC = NO_x absorption catalyst DPF = diesel particulate filter SCR = selective catalyst reduction (urea)

Notes:

SO YOU WANT FUEL ECONOMY

PART ONE - THE BASICS OF VOLUMETRIC EFFICIENCY

The search for better fuel economy perhaps is the reason that you have downloaded the TDR Buyer's Guide. Regardless of the reason, one should understand the mechanical workings of the engine (volumetric efficiency), lest you are fooled by the salesman at the truck stop that tells you his miracle computer chip turbo encapsulator or diesel particulate filter delete kit is the ticket for better fuel mileage.

Back in the days of mechanical fuel injection pumps (vintage '89-'98 12-valve trucks) the TDR editor, Robert Patton and TDR tech guy, Joe Donnelly, collaborated on an article that discusses the mechanical side of fuel economy. From Issue 29, August of 2000, join the writers in their discussion of volumetric efficiency, as the flow of air through the engine has a direct effect on your miles-per-gallon.

Then, use your understanding of the engine's mechanicals to shop wisely for best air tornado or strongest fuel magnets (just kidding) to increase the truck's fuel economy,

FUEL ECONOMY WITH POWER

By Joe Donnelly

How often *have* you heard a Turbo Diesel owner brag about the two things we *love* so much—power and economy? First he says his truck can tow umpteen thousand pounds up a cliff at 75 miles per hour. Then he says his Turbo Diesel gets 47 miles-per-gallon doing it! Certainly, we would admit no less to the PowerStroke owner on the next seat at the counter. In previous Technical Topics, we *have* discussed some strategies for increasing power, in case we want “just a little more” to humiliate that Ford or *Chevy* pulling a similar trailer up the hill behind us (in our stories, they are *never* next to us or in front, of course!). In this issue, we will discuss some real-world strategies for improving miles-per-gallon (mpg). Even if 47 is an elusive goal... (Now, admit it, you know darn well you *never* got over 42 mpg, and that it dropped all the way to 37 mpg when towing your 40', 18,000 pound fifth-wheel!).

Okay, folks. Enough stretching of the truth (creativity, lying, or *whatever* you call it). A few of us admit, in strict privacy of course, that our beloved Turbo Diesels don't *even* get 20 mpg (under some conditions, or *ever*, depending on the individual truck and owner). That magic number 20 seems to be the price of entry into the Turbo Diesel Hall of Fame. When measuring fuel consumption, first of all, be sure your measurement is accurate. It is *very* easy to get fooled. Here is a typical scenario that results in Mr. Rammer swearing his ride gets 27 mpg: First Mr. Rammer fills the tank slowly, taking a half hour to squeeze in the last few gallons around the foam in the filler neck. The truck is tilted forward and to the right, and rocked frequently by hand, so the last bit of airspace can be displaced with precious #2 diesel. Carefully and tightly, he screws on the filler cap, but quickly so none of the fuel can drool out. For step two, a trip of 100 miles is taken, mostly downhill with a tailwind. Then, the tank is refilled quickly, and considered full when the nozzle clicks off the first time. Lo and behold, 2.13 gallons registered on the pump! Almost feverishly, Mr. Rammer pulls out his

calculator and with shaky hand punches in 100/2.13 and voila—27 mpg!

Get the point? Mileage must be calculated over a long distance of similar speed/terrain/driving, or representative and mixed types of driving, for you to tell much about the efficacy of a modification. Repeated measurements taken over an extended period of time, and averaged, make for much better accuracy. Fill the tank the same way and at the same pump *every* time. “Almost” 20 often becomes 19 or *even* 18.5 mpg when you *remove* the “inadvertent” fudge factors—like rounding the miles up and rounding the tenths of a gallon down. By now Mr. Rammer is irate because I *have* impugned his *veracity* (uhhh, called him a liar, but politely). Even if our Turbo Diesels don't all get 20+ mpg, they can give decent mpg and power too. Let's go through some modifications that enhance mileage without hurting power, and some that increase power without hurting mileage. Some things help both!

For purposes of this discussion, I *have* tried to be as impartial as possible in calculating mpg while testing changes, and the types of improvements worth trying. As much as it hurts, I *have* to admit that the test Turbo Diesel *gave* under 20 mpg (gasp!) under “certain” (folks, that really means, almost all) types of driving. Here in the West, there are large open spaces, 75 mph speed limits *even* on two lane roads, and good opportunities to pass those who feel that 50 is the right speed. Of course, these folks are encountered only in no-passing zones, so aggressive use of the right foot is called for (grin) to pass them when there is finally a chance. At any rate, let's note that, as a baseline, the test 215 hp Turbo Diesel has given the same range of mileage *over* time since new, until making changes in injectors and pump timing, and that the driver's right foot (read: hard acceleration and top speed) is the biggest factor in the mileage. It could get, and has gotten, *over* 20 mpg with gentle application of the loud pedal, but typical figures are in the 16-19 mpg range for city and highway driving, using the capabilities of the mighty Cummins engine as “needed” and taking into account the poorer mileage that is typically encountered with winter blend diesel fuel. Practical tips in this article will help you increase your miles-per-gallon results, without doing anything “radical” like putting a 50 lb. spring on the accelerator.

In no particular order, some of the bigger add-ons that can hurt mileage include aftermarket front bumpers or brush guards (0.5- 1.5 mpg), air and bug deflectors (0.5-1 mpg in the worst cases), and other wind dragging items like large mirrors and high profile bed caps or trailers. Interestingly, so-called airflow tailgates do not seem to help at all. Their major benefit may be the ability to see the roof of the minicar you are crushing when you back up! Dodge said that they worked the aerodynamics of the Turbo Diesel with the tailgate installed and closed, and that we should drive that way for best results (Issue 21, page 50). Monster, oversized tires hurt several ways: rolling resistance, inertial loading (both accelerating and stopping), and weight. Underinflated

tires hurt mileage too. Carefully choose an inflation level that puts the whole tread on the road with the load you are carrying. That will usually be somewhere near the maximum inflation pressure for the tire. For example, you might run about 55 psi in the front with tires rated for 3,000 lb. at 65 psi. When empty, the rear tire pressure could be lower, perhaps 50 psi. Check with your tire company for specifics to your tires. As has been noted in the TDR several times, mpg is reduced by four wheel drive, 4.10 gears (*vs.* 3.54), automatic transmission, and dual rear wheels. Obviously, weight also reduces mpg, whether in the form of vehicle options, cargo, or a trailer.

Relatively minor effects upon mileage can add up. Reducing cruise speed and rpm help. However, remember the Turbo Diesel transmissions are susceptible to damage from vibration at low rpm; thus it is preferable to cruise at 1,900-2,200 rpm as a compromise. Cruise control can help about 1 mpg (unless you have a heavy load and it is hammering the pedal all the time). A disconnecting fan such as the Horton can help a bit too under some circumstances. Radiator shutters in the winter enable the engine to reach a high enough temperature to operate efficiently. Overdrive helps in our Turbo Diesels, but if direct drive (4th in the five-speed, 5th in the six-speed, and 3rd in the automatic) could be used to maintain the proper engine rpm, a small gain in efficiency would be realized (perhaps 0.5 mpg). Along the same line, adding overdrive units can reduce efficiency somewhat, depending on what gear ratio is in use and what lubricant is used in them. Synthetic or specially manufactured lubricants help a little, too. The Mopar Plus 3 automatic transmission fluid is semi-synthetic, and the manual transmissions use synthetic fluid from the factory. Good quality synthetic lubricant in the differential(s) will help reduce friction and hence improve mpg slightly (you may not see the gain, as it will be small). Cold weather diesel fuel blends generally give 1-2 mpg less than summer fuel. Premium grade summer fuel may be the best in this regard, depending on how the higher cetane rating was achieved. If you add up a bunch of the above tips, you might get 0.5-1.0 mpg better, but don't expect too much in the real world where so many other factors are involved.

Lower restriction exhaust, from the turbocharger housing on-back, can help a bit. The engine has to do less work to remove the exhaust, and less turbocharger boost incurs less pumping loss, so long as the boost level is sufficient to burn the fuel efficiently. The stock muffler is a source of some restriction and a straight-through design can cut restriction. For most folks, the factory 3" diameter used from 1994 up is probably quite sufficient, and it is certainly less expensive than buying a complete 4" system. A larger exhaust turbine housing can improve economy a bit by reducing the pumping loss that is caused by forcing the exhaust through a small orifice. The stock turbocharger exhaust housing is the biggest restriction in the 1994-up Turbo Diesel's exhaust. This turbine housing size must be balanced against responsiveness of the turbocharger (spool up) which tends to decrease as the housing becomes larger. The biggest Cummins engines are characterized by lower pressure in the exhaust manifold (turbo drive pressure) than boost pressure. With the HX35W turbocharger used on the Turbo Diesels, drive pressure is usually higher than boost

pressure. With the stock wastegated 12 square centimeter (cross sectional area) turbine housing, drive pressure can be nearly double the boost pressure. The engine has to do work to force the exhaust through the housing, which in the case of the 12 sq. cm. is the equivalent of a 1.5" inside diameter exhaust pipe, and is 49% the size of the turbo outlet! The engine does work to create boost, and that uses fuel. In general, you want just enough boost to efficiently burn the fuel that is needed to make the power requires.

General driver habits make a big difference! Rate of acceleration, coasting down versus hammering the brakes, using cruise control, maintaining a moderate speed, limiting accessory use (such as air conditioning), making smooth starts, and minimizing idling and run time when stopped: these are all important in achieving maximum fuel mileage.

Volumetric Efficiency and BSFC

Now, on to some magic and diesel engine theory as applied to our situations. Our engines make the best use of the fuel if it is injected at exactly the right time. It will then burn when the piston is positioned in the bore correctly so work can be done on it—it can be pushed down the bore, turning the crankshaft. If the fuel burns too soon, the force on the piston is inefficient because the piston is too close to top dead center, where the crankshaft is not positioned to turn as a result of force on the piston. If the fuel burns too late, the expanding gases do less work, there is less pressure on the piston, and much of the heat is ejected into the metal parts, water jacket, and exhaust system. Many of us have found that our engines can give excellent fuel economy when used at low power levels and low rpm. Two of the basic reasons for this observation are (1) the relatively small injectors used as original equipment in our engines are just the right size to inject a little fuel over a sufficiently small time interval for good efficiency; (2) the moderately advanced pump timing (generally 11-14 degrees) provides for fuel burning at the right time at moderate rpm and with fuel being injected over a short time interval; and (3) frictional and pumping losses are moderate at lower engine speeds.

Editor's note: In jest, Joe discusses "magic and diesel engine theory." As I read the paragraph describing "the best use of the fuel if it is injected at exactly the right time," I drew a quick parallel to two often discussed (Issue 7, 9, and 20) technical terms, Brake Specific Fuel Consumption and Volumetric Efficiency. In layman's terms, brake specific fuel consumption is the efficiency of an engine. BSFC is simply a value that helps us describe the engine's ability to convert fuel into horsepower.

BSFC tells you how much fuel it takes your engine to produce each horsepower. The lower the BSFC value, the greater the fuel efficiency: Fuel consumption (gallon/hr) = (Bhp × BSFC) ÷ 7.1 lbs/gallon fuel. To better understand the BSFC let's plot its resulting graph for two engines, a '92.5/CPL 1579, Cummins 160 horsepower engine and a '95/CPL 1550, Cummins 175 horsepower engine. Next to the BSFC graphs let's plot the engine's torque and horsepower graphs.

Did you notice the lowest (best) BSFC occurs at the same rpm as torque peak? Coincidental? I don't think so! Both are determined by the engine's ability to completely fill, compress, combust and exhaust air!

Let's now see if we can get an understanding of Volumetric Efficiency. Take a look at the torque and horsepower curves. As torque and rpm rise, horsepower also rises into the midrange of the engine. Obviously, greater torque results in more horsepower. Ed Fortson of 4-Wheel and Off-Road does an excellent job of describing volumetric efficiency.

"At a certain point—varying with engine design—the torque curve drops off. Why? Remember that a big factor in torque production is the combustion pressure on the pistons. This pressure is greater at lower engine speeds, when the rpm allows more time for a bigger air charge to be drawn into the cylinder, more time for efficient combustion and for exhaust gases to be expelled. Engineers say that the volumetric efficiency (VE) is greater at low rpm—VE being a description of how well the engine draws in air. The formula looks like this: $VE = \text{actual air volume intake} \div \text{intake volume in ideal conditions}$.

"As rpm increases, there comes a point—again depending upon engine design—when combustion pressure decreases, due to factors such as valve size and timing, fuel delivery and air flow through the intake and exhaust systems. In other words, VE decreases.

"Notice, however, that horsepower continues to increase for a time even after torque falters. This is due to increasing rpm, the other factor in horsepower production. And this is why you've probably heard that horsepower buys top speed whereas torque buys low-end power. It's torque, not horsepower, you feel when you first punch your throttle.

"Finally, as the chart shows, horsepower is also dragged down by falling torque, increased friction and speed-related engine inefficiencies.

"Of course, the more torque you have to begin with, the more horsepower you'll have and you'll have "it lower on the tach—ideal for pulling/hauling. Likewise, the higher and flatter the torque curve, the better midrange and top-end performance you'll have—ideal for highway cruising.

"The bottom line: No matter what kind of pulling/hauling you do, torque is the heavy hitter!"

Final note, volumetric efficiency reaches its peak at the rpm at which the torque peak occurs. The physics to produce torque peak requires the greatest cylinder filling or volumetric efficiency.

Interesting stuff? What does it mean to you? I hope you've learned from the efficiency relationships that it would be best to put your engine on cruise control at a speed corresponding to 1,600 rpm for the given 12-valve

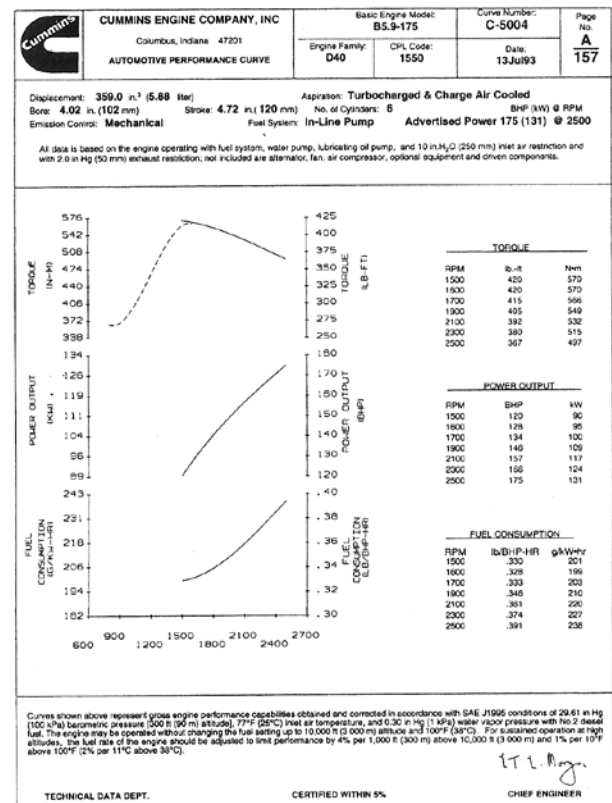
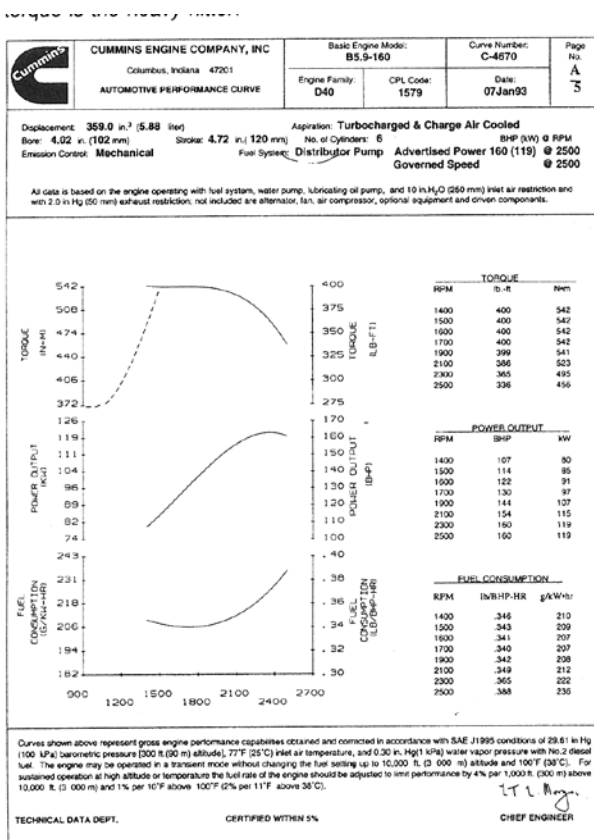

performance curve. For 24-valve owners please see our discussion in the 24-valve topics on page 48. At 1,600 rpm you've got the torque peak of the engine available to keep your speed constant as you encounter a grade. If your speed drops below 1,600 rpm, you had better downshift because it's all "downhill" (back side of the torque curve) from there. You've obviously exceeded the maximum torque produced by the engine and multiplied by the gearbox/rear end ratio of the load you're trying to propel.

Is it possible to cruise at 1,600 rpm? In Atlanta, to avoid being run over by traffic, you'll have to exceed the 1,600 rpm setting. Also, cruising at this lower rpm range is not good for the transmission components. Nevertheless, we've enlightened you to seek 1,500/ 1,600 rpm for the best engine efficiency and mph. Thus now you know why my favorite questions for a low mpg complaint are, "How fast do you drive? What is your rear end ratio?" Hmm...low mpg trouble shooting, sounds like a future article. Or, is it simply a matter of driving at a lower rpm/ better BSFC number?

The Injector Topic

As we move to higher power applications (whether the engine is stock or fueling has been, enhanced) where more fuel is needed, bigger injectors can inject the needed volume of fuel over a significantly shorter time interval than small injectors can. In this context, big or small refers to the size and number of injector holes or orifices. If the fuel is injected at the right moment, it will burn most efficiently. Smaller injectors would use a larger time window, and some of the fuel injected late would be wasted. Hence, more fuel would be needed with small injectors to produce the same power, and byproducts of this inefficiency would be waste heat and smoke. That does not mean you need to change the injectors when you add a moderate amount of power (say, on the order of 50% over stock) with a torque plate or electronic box; the stock injectors will work, they are just a bit less efficient, and if you raise the power a lot, they are too small.

Depending on the rpm range being used, a bit more injection pump timing will reduce smoke significantly, increase fuel mileage, cut exhaust gas temperature a little, and cut mid range torque somewhat. Pump timing (P7100) in the range of 15-16 degrees works well for some applications. For example, in the case of the test 215 hp Turbo Diesel, average unloaded mileage went from 16-19 to a consistent 19.5-22 mpg with a change in injectors and pump timing, for highway driving at 1,900-2,200 rpm.

Twelve-valve Turbo Diesels with the P7100 pump and lower hp ratings than 215 may benefit somewhat from 215 injectors for mpg, while gaining 20-30 hp. The 215s can go to Bosch injectors for marine B engines. The 24-valve engines respond nicely to the 275 hp Bosch injectors. Feedback from a number of owners indicates that a 1.5 mpg gain is pretty generally realized on the 24-valve engines, along with some gain in horsepower (about 33 hp and 60 ft. lb. on manual transmission Turbo Diesels, 50 hp and 100 ft. lb. on automatics). Other aftermarket injectors may add more

power than that, and time will tell how well they perform compared to Bosch in the long term. Thus, the theory of injecting the fuel at the optimum moment for most efficient burning is confirmed by real-world testing.

Editor's note: You may say to yourself, "Gee, it looks all too simple ... change (advance) the timing of the fuel delivery (on the 12-valve engines this is a mechanical change, on the 24-valve engines the auxiliary "black box" does the timing change) and throw in a set of big injectors for better mileage and power. Pretty simple, eh? Why didn't those guys at the factory do that?" The answer is as simple as two words: EXHAUST EMISSIONS! DIC and Cummins have to play by a different set of rules than the owner of the vehicle. It is true that tampering with or disabling any component of the emissions (timing changes and big injectors are included here) control system is a direct violation of federal law (fines up to \$25,000 per day, per violation). Owners have to weigh the consequences versus the increase in performance (Issue 26, page 32).

Are the performance vendors playing by the same set of rules as DIC and Cummins? You'll have to ask them as you make your performance included here) purchase decisions. My experience has been that the answer is no.

Fuel Pump Timing

In a discussion about changes to timing, turbochargers, and injectors, we should be aware that technically they are part of the emissions-certified package produced by Cummins. Timing, for example, is set within plus-or-minus one degree of the nominal. This tolerance allows Cummins some latitude on the assembly line while ensuring that their engines meet the stringent federal emissions requirements. These requirements are generally much stricter than the allowable ranges for in-service state tests. Cummins has responded to tightening emissions requirements in the past with the introduction of the intercooler (1991), the higher pressure P7100 pump and catalytic converter (1994), exhaust gas recirculation (California, 1996), and the 24-valve, electronically controlled engine (1998). Most recently, Issue 18, pages 46 through 50, goes into detail covering the hardware changes to these different engines.

These changes were made to lower the exhaust emissions, not to increase power.

Josh Berman of Cummins has responded to questions in the past with the following brief summary regarding injection pump timing:

"For Cummins' Band C-Series engines, the timing is part of the CPL (Control Parts List), which is basically the emissions 'recipe' that we use when we certify the engine with the EPA. There is a tolerance band around that timing. Timing is one of the many things that the performance engineers consider when they're developing a rating. Putting it simply, they have to balance cylinder pressure limits with emissions and power requirements."

Advancing the timing will... (good characteristics)
Increase cylinder temperatures/pressures (power)
Increase fuel economy (yes, economy is better)
Decrease exhaust temperature
Decrease your output of Hydrocarbons – a pollutant

However, advancing the timing will... (bad characteristics)
Increase the amount of black smoke particulates – a pollutant at peak torque
Increase your output of NO_x – a pollutant

[quoted material by Josh Berman, Cummins]

Particulates and NO_x pollutants are the key items Cummins/DaimlerChrysler has to be concerned with. Clearly, it is “pretty simple, eh?” to do economy/performance timing/injector changes, yet the manufacturers have to play by a much stricter (EPA) set of rules. Meeting legislated exhaust emission guidelines forces Cummins to make economy/performance compromises. Have you heard this sermon before?

We discussed exhaust improvements in general above. To be more specific, stock Turbo Diesels need little if any exhaust improvement (so long as the catalytic converter used with 94-up 12-valve engines is not plugged). A lower-restriction muffler (and somewhat bigger pipes on the '89-'93s) is probably enough, and may or may not give a noticeable increase in mileage, depending on your type of driving. Once the engine has had its fueling “enhanced” to the point of about 250 hp, the above exhaust changes become more significant, and a larger turbocharger exhaust housing begins to help as well, especially if the extra power is used often. Even if the power is not being used, the general improvement in exhaust flow (reduction in backpressure) can make a small but observable improvement. Beyond the improvement that can be realized from low restriction 3” exhaust, a small improvement might be seen with 4” diameter pipes, noticeable when power is at least in the 375 hp (or greater) range, measured at the wheels. However, to realize the potential of 4” exhaust, it is important to convert the engine to a properly designed and sized turbocharger designed for the larger exhaust size but still small enough to work efficiently with a 359 cubic inch B series engine. Probably because of the electronic air-fuel controls built into the computers on the 24-valve engines, they do not seem to respond well to the 16 sq. cm. turbine housing on the stock HX35 turbocharger. The smaller 14 sq. cm. housing seems to work for them, however, and is bigger (less restrictive) than the 10 and 12 sq. cm. housings that are stock on 24-valve Turbo Diesels.

BEYOND “WHAT IF,” GOING TO 400 HP

Researchers at BD Engine Brake and at TST recently went beyond the “what if” stage of dreaming about what such a Superturbo would be. These dreams resulted from tests of Turbo Diesels with B engines in the 380 to 400 hp range. In that power range, TST considered that boost under full power was high enough to be beyond the efficiency map of the stock Holset Model HX35W turbo, even when relatively large turbine housings were used. Total boost at

full power was more reasonable with the 21 sq. cm. housing, but responsiveness definitely suffered, and egt was not observably lower than with the smaller 16 and 18.5 sq. cm. housings. This 21 sq. cm. housing provided an internal cross-sectional area about 87% as large as the turbo outlet, which is about 2.4” diameter but restricted by the 1” diameter pinwheel hub. A much better compromise for that power level was achieved with the 18.5 sq. cm. exhaust housing, the same size that Dodge used on many of the First Generation Turbo Diesels. This size housing corresponds to 76% of the turbo outlet area. Boost under full power, however, was higher than with the 21 sq. cm. housing, so a wastegated housing would be ideal to keep cylinder pressures down, and to keep the boost closer to the efficiency range for the turbocharger’s compressor. The stock Turbo Diesel exhaust manifold outlets are close to 18.5 sq. cm. in area. Below about 350 hp, the 16 sq. cm. housing was the best compromise (at 66% of the outlet size), especially when smoke was considered along with responsiveness.

These studies indicated that the compressor side of the turbo should be a bit bigger for high horsepower Turbo Diesels, and an 18.5 sq. cm. wastegated exhaust housing would be a good compromise for high powered Turbo Diesels, particularly if the turbo outlet was sized properly for 4” exhaust pipe. For this to happen, we expected the exhaust pinwheel to be a bit larger than with the HX35, but not the full 3.25” diameter that the outlet would be sized to match up with a 4” exhaust pipe using a band clamp retainer. The primary factor in turbo spoolup is the expansion of hot exhaust gases. A pinwheel of about 2.5” diameter with subsequent expansions to 3.25” and finally to about 3.9” diameter should give excellent spoolup

After BD identified a candidate HX40W turbocharger from a C series (505 cubic inch engine) Cummins, they tested it first on a Turbo Diesel with enhanced fueling and an automatic transmission.

Results were amazing, as will be discussed in a moment. For reference, with the HX35W, a 16 sq. cm. exhaust housing gave slower spoolup with a tight stall speed torque converter, so a 14 sq. cm. housing had been generally used on that Turbo Diesel, even though over 1,800 degree exhaust gas temperatures (egt, in the exhaust manifold) could be achieved under full power. At 40 psi boost, drive pressure was 55 psi. With the HX40 Superturbo, spool up was fast even though the exhaust housing was 18.5 sq. cm. in area. Drive pressure at 46 psi boost was only 40 psi, and egt was reduced to 1,500 degrees maximum. The TST test Turbo Diesel received the second Superturbo and collected data regarding its usefulness for a five-speed application. Even with a ported head to reduce egt, this Turbo Diesel had been able to achieve high enough egt with the HX35 turbo that the pyrometer probe was easily pegged above 1,600 degrees. Therefore it was moved to the exhaust elbow under the theory that approximate data, corrected by 10 degrees per psi boost, would be better than no data from a pegged needle! With the fueling level of this Turbo Diesel, 1,200-1,400 degrees egt in the elbow after the turbo was easily achieved using the HX35W turbo and low restriction 3” exhaust at 40 psi+ boost. The HX40 Superturbo with 4” exhaust brought the egt down to around 800 degrees with

boost wastegated to 45 psi maximum.

What does this Superturbo experiment mean for economy? Towing 5,000 lbs., the mileage of the five-speed Turbo Diesel went up about 0.5-1 mpg with the Superturbo. Further testing is in order, of course, but these preliminary results indicate that a Turbo Diesel can give fine economy when driven at moderate power levels. The reduction in pumping losses is beneficial to economy as well as to power. The fantastic Cummins not only makes great power, it can do so while giving better mileage than stock!

What does all this mean for the more "reasonable" Rammer? Horsepower in the range of 230-275 is most likely "enough" and you don't need to spend a lot of money or lose mileage or reliability to get there. You can start spending money to enhance economy, but don't expect the work and parts to pay for themselves quickly! When you want a lot more power than that, you are asking to spend dollars for performance parts. You're also asking for trouble. You avoid this trouble by spending money to beef-up the rest of the truck. With the 12-valve engines, you can add power with a torque plate and boost control, and set the pump timing if needed for around \$600, parts and labor. For a similar amount of money, you can put larger injectors in the 24-valve and gain power and mileage.

In summary, you can leave your Turbo Diesel stock, add moderate amounts of power, or add lots of power, and still get good mileage. You can choose modifications that help mileage. Thus, there are things that add mileage and things that add power, and some add both. How much do you want to spend to save money on fuel?

Joe Donnelly

Editor's note: In summary, could the "Beyond 'What If,'" super- duper, gonzo, HX40W turbocharged engine meet an EPA emission test? Doubtful. Do you care? You know the consequences (Issue 26, page 32)? Do you care? We conclude this article with the often-repeated mantra: It's your truck. It's your money. Make an informed decision. Accept responsibility! If you choose to make performance modifications, you are your own warranty station.

SO YOU WANT FUEL ECONOMY

PART TWO - ALL YEAR MODELS AND UPDATES

IT'S ABOUT THE (FUEL) ECONOMY STUPID! by Robert Patton

No, I'm not running for office this election year. But, with my knack for the obvious, I know the focus of attention is fuel economy. So much so that I could be accused of head-in-the-sand mentality were I not to acknowledge that I've heard many conversations about parking the truck and purchasing a beat-up economy car.

I've thought the same. Before you make a like decision, be sure to factor all of the cost. You'll likely find that the beater car's payback is longer than you first realize.

Nonetheless, I wanted a quick solution to the fuel economy crisis. So, I went to Wal-Mart.

No magic fuel magnets were found on the shelf. Out of stock.

The air tornado thing was not large enough for my truck's intake.

The fevered pace with which I started this article was now in neutral. If the fuel magnet or the tornado salesman had come calling I would have purchased the products out of sheer frustration. Maybe I should do some further research.

As I look back, it was 10 issues ago (Issue 51) or the winter season of 2005/2006 that we had the TDR writers tell us about their strategies for driving their diesel in a \$3 gallon world. This was just after hurricane Katrina, but prior to ULSD fuel and the higher world wide demand for diesel. Diesel fuel was still lower or equal to the price of regular grade unleaded gasoline. Diesel owners were still pleased with their choice of engine and we enjoyed the benefit of the engine's 35% better fuel economy than the gasoline counterpart. Today's price premium for diesel fuel (about 20% here in Georgia) really hurts.

So, I went back to Issue 51 to see how easy it might be to write a sequel article. I was captivated by the writer's stories.

Issue 51, like a conversation with an old friend, is worth your reread.

- Doug Leno's cost/benefit analysis on fuel economy gadgets.
- Brad Nelson's pinecone and boost build-up driving technique.
- Bruce Armstrong's EGT at 600° driving technique.
- Greg Whale's analysis of price versus Europe where fuel was \$6 for diesel and \$8 for gasoline.
- Scott Dagleish's fuel economy project truck and the connection of the wallet to the right foot.
- John Holmes' price of fuel versus minimum wage comparison.
- Jerry Neilsen's pledge to slow down and use the cruise

control. Jerry also noted that "everything is a matter of perspective."

- Joe Donnelly points out the obvious and refers the readers back to Issue 47.
- Mixed in with the fuel economy comments you can't miss the late Ron Khol's tell-it-like-it-is political commentary.

Throughout Issue 51 several writers made reference to Joe Donnelly's "Fuel Economy with Power" article in Issue 47. So I picked it up and searched for information. Rather than reinvent the wheel (actually Issue 47's article was an update from Joe's Issue 29 material), I'll review with you some of the Issue 47 text.

The first thing that caught my attention was the cliché often seen in the TDR, "The more things change the more they remain the same." As this bit of reality set in, it slowed my fevered pace to find the key that would unlock a dramatic fuel economy breakthrough.

Regarding fuel mileage (and for that matter performance and exhaust emissions), this bit of reality was presented in Issue 47.

"Editor's note: you may say to yourself, 'Gee, it looks all too simple...change (advance) the timing of the fuel delivery (on the 12-valve engines this is a mechanical change; on the 24-valve engines and HPCR engines many of the auxiliary black-boxes do the timing change) and throw in a set of big injectors for better mileage and power. Pretty simple, eh? Why didn't those guys at the factory do that?' The answer is as simple as two words: exhaust emissions! Dodge and Cummins have to play by a different set of rules than the owner of the vehicle. It is true that tampering with or disabling any component of the emissions control system (timing changes and big injectors are included here) is a direct violation of federal law (fines up to \$25,000 per day, per violation). Owners have to weigh the consequences versus the increase in performance, and in this example, fuel mileage (Issue 60, page 50)."

Some other summary points from the Issue 47 text:

The article provided a great refresher for 12-valve and 24-valve owners. Of particular interest to all of the TDR audience is the discussion on brake specific fuel consumption (BSFC) and volumetric efficiency (VE). We provided the performance curves for an early Dodge 12-valve, 175 hp engine. We also provided a preliminary performance curve for an early 24-valve (non-Dodge application) engine. Unfortunately the Dodge-specific curves for the '98.5-'02 engines were never published for the Cummins network, as the Dodge engine is not an engine sold through the Cummins distributor system. The same story holds true for the '03-'08 Dodge-specific Cummins engines.

Regardless, we can all learn from the BSFC and VE discussion and benefit by driving close to the engine's BSFC

and VE “sweet spot.” For 12-valvers it’s 1600-1700 rpm; for 24-valvers it’s 1600-2000 rpm; for HPCR engines it is a higher 1900-2100 rpm range as confirmed in discussions with Cummins Inc. engineers.

From these performance curves I want you to focus on the bottom chart “Fuel Consumption.” The measurement used is brake specific fuel consumption (BSFC). In layman’s terms, brake specific fuel consumption is the efficiency of an engine. The BSFC number is simply a value that helps us describe the engine’s ability to convert fuel into horsepower.

BSFC tells you how much fuel it takes your engine to produce each horsepower. The lower the BSFC value, the greater the fuel efficiency: Fuel consumption (gallon/hr) = (BHP × BSFC) ÷ 7.1 lbs/gallon fuel.

Been There, Done That; Got Lots of Spare Parts

As much as I would like to pretend that I am a diesel engineer and offer you a magic fuel economy fix-all, the reality is that as a group we have already been there and done that. So much for the sensational title line that I could splash on the outside cover, “Writer Dude Discovers 25% Greater Fuel Economy for His Dodge/Cummins Turbo Diesel.”

Back to the task at hand, can you increase the fuel economy of your truck? Oddly enough Issue 51 was the second article in Scott Dalglish’s quest to improve the mileage on his ’05 Turbo Diesel 2500, 4x4, Quad Cab with the G56 six-speed transmission and 3.73 rear differential ratio.

Rather than send you back to your archives to gather the information, I’ve assembled a brief summary of each of his articles.

Read the summaries and let’s see if we reach the same conclusion(s) at the end.

I 50 Baseline MPG 15.8 city; 9.8 towing.

Added TST PowerMax CR, Amsoil synthetic lubricants, Mag-Hytec differential cover, gauges, fresh air box with aFe Proguard 7 filter. Notes: Playing with different timing settings the TST PowerMax CR showed an increase of up to 13% better mileage.

I 51 Added Gear Vendors overdrive, Banks High Ram inlet, Banks intercooler, Banks Monster exhaust. The combined effect of the aftermarket products thus far: up to 17% better.

I 52 Added BFGoodrich 285/70/17 tires which reduced engine’s rpm by 100. Experimented with pre-production Banks Six-Gun Tuner and Power PDA. The combined effect is still in the 16-17% range with the power setting on the Banks unit at “2.”

This comment caught my eye: “Power settings above 2

provide marked performance increases along with an equal increase of driving fun. But the fun has a cost and decreased fuel economy is the price.”

Scott is about to “go over to the dark side,” “fall off the wagon”; choose your cliché. This article was written in the May 2006 time frame when the pre-Katrina fuel price is at a stable \$2.25.

I 53 No report.

I 54 Recap of baseline at 15.8mpg. Noted increase of mileage to 18.7mpg. Added Industrial Injection Super Phat Shaft 62 turbocharger and PDR camshaft. Scott noted that the turbocharger neither hurt nor helped fuel economy.

I told you Scott had moved to the dark side. Notice the emphasis on performance: “The setting of the Banks Speed Loader was 6 and the 0-60mph time dropped from 10.2 seconds to 8.9 seconds.

In the Issue 54 article Scott noted that the PDR camshaft had a dramatic effect on economy—approximately 2.1 mpg. Great news! But, why didn’t the Cummins engineers think of that?

They did.

Scott’s explanation from Issue 54: “If obtaining better fuel economy can be found from a different cam grind, why didn’t Cummins do it?” The answer is Cummins Inc. can provide camshaft grinds for better fuel economy. But, as I stated earlier, Cummins has to abide by a different set of standards, which are primarily emissions driven. (**Editor’s note: Sounds familiar, doesn’t it?**) In order to meet current NO_x standards, combustion cylinder pressures must be lowered. One way to accomplish this goal is to retard injection timing, reducing cylinder pressure and thereby reducing NO_x. The Catch 22 is that it takes more fuel to operate the engine in this manner. The engineer has to certify clean exhaust emissions, often at the cost of fuel economy. So will the cam offered by PDR meet EPA emission standards? To our knowledge it has not been tested for EPA compliance and probably would not pass. Would it pass a local emissions test as administered (snap idle)? Probably.”

I 55 Scott is to the point: “In my review of some of the back issues I realized I have made a transgression. I have once again, fallen to the temptation of more power. While it is true we are close to accomplishing our goal of 20% better fuel economy across the board, the alluring power increases have blinded me like a moth drawn to a bright light. I now believe that it is possible to obtain the 20% fuel economy goal AND increase horsepower to the 500-rwhp mark. Along with this revised goal I had to accept the reality that was true for me way back in Issue 23, the financial impact of all of these fuel mileage and performance goodies will never be offset by the 20% economy I may someday achieve.”

Further, Scott writes, “This isn’t to say I have forsaken
A Publication of the **TURBO DIESEL REGISTER**

the fuel economy project. Currently we are averaging about 18.1 mpg. That is approximately a 15% increase across the board (solo, towing, city and highway). We have produced as much as 18.8 mpg driving solo combined city and highway, which is a 19% increase! But we have shifted from some of the original stated criteria. Most notably, 'to remain emission compliant and to maintain the factory warranty.' Some of the parts we have tried may not be emissions compliant (no current emissions testing data is available) and their effect on warranty is subject to debate.

"Knowing this up front, you are faced with a dilemma. Will you a) live with the fuel economy offered by the current HPCR engine's configuration; b) make some of the changes which provide some fuel economy improvement and leave the engine warranty intact, or c) become your own warranty station and move in the direction which will provide the best fuel economy and performance available?

"On the topic of emissions compliance: most, if not all, of the products tested to date will pass the current snap-idle emissions testing which is performed in some states today. Would these products pass the current Federal standards? Probably not. We do not have access to the test equipment nor is there a standard procedure for such testing after a product is sold to the end user. Since no testing of the Federal emissions standard (EPA or CARB) is currently in place (the exception being for manufacturers), it is a moot point."

TDR members, if you reference Issue 60, pages 50-52, you will likely conclude that parts testing for emissions certification for the '03-'07 HPCR engine is still a moot point.

I 56 Noted a decrease in mileage of 7% that was attributed to the required ULSD fuel (January '07). Added DDP injectors and mileage checks in at 18.9 mpg.

I 57 Added Leer truck cap, but noted no difference in economy.

I 58 Changed turbocharger to a Turbo Re-Source unit. Mileage is 19.1 using Scott's combination solo runs on the short and long track.

I 59 A higher performance set of DDP injectors (DDP90) and an emphasis on horsepower. Fuel economy went down 6%. Overall economy is better by 14%

I 60 No report.

I 61 See Scott's turbocharger write-up on page 92.

Conclusion(s)

Credit to Scott—in his adventure seeking fuel economy and performance, he took the time to address three important concerns: Why didn't the factory engineer for fuel economy? What happens to emissions compliance? What are the effects to the factory warranty?

As I looked back at his findings, there was one modification where I could see a cost justification and two nice-to-have modifications.

The item that can be cost justified: The use of a performance box that modifies the timing of the fuel injection event. Cost: \$800. Number of gallons that you would need to save (@\$4/gallon) to payback the \$800 ($\$800 \div \$4 = 200$ gallons). From his Issue 50 Scott found that the mileage increased by 13% or $15.8 \times 1.13 = 17.8$ mpg.

Drive 30,000 miles $\div 15.8$ mpg = 1,898 gallons used
Drive 30,000 miles $\div 17.8$ mpg = 1,685 gallons used
213 gallons saved

Okay...drive the truck 30,000 miles and you've paid for the performance/timing box.

The nice-to-have modifications: The camshaft and the overdrive unit.

From Issue 54 Scott noted the cost of the cam and installation was \$1600. He noted a 2 mpg increase. Yet the 2 mpg was lost (the numbers should have gone up to 19.8 mpg) in his quest for power. But, for the sake of argument, let's assume another 2 mpg improvement.

At $\$1600 \div \4 gallon you need to save 400 gallons of fuel to pay for the camshaft. This would take 60,000 miles.

And the nice-to-have overdrive? Writer Loren Bengston covered the payback for his overdrive unit back in Issue 47, page 162. In Scott's case insufficient data exist to do a calculation.

Bottom Line

It seems simple to me...

- As we learned from Joe Donnelly and Issue 47, operate the engine at the BSFC rpm that corresponds to the engine's sweet spot. Unfortunately, highway speeds don't allow you to go that slow without impeding traffic, so slow down as much as possible.
- Change the engine's timing. Scott's findings and the article by Joe Donnelly on page 98 confirm that this modification is applicable for all years of the Turbo Diesel truck. Be careful of the cause and effect and realize that the payback could take a while.
- All of the other modifications are discretionary.

Robert Patton
TDR Staff

P.S. Wal-Mart is *still* out of stock on the fuel magnets and the tornado thing *still* has not been released for our intake size.

VENDOR RESPONSE TO THE NEED FOR TEST DATA

by Robert Patton

Realizing that there was limited data to substantiate the timing cause-and-effect, I sent a letter to several vendors that were listed in Issue 47's and 48's articles on performance for the '03-'07 HPCR engine. The articles were authored by writer Doug Leno and Doug provided a comparison matrix that showed vendor products that effected timing.

Doug's write-up (Issue 47 and 48) was done in mid-2005. Since that time there have been numerous other products introduced to the market that effect timing. I was remiss in not asking those vendors to respond. Admittedly, I am belated in keeping tabs on the performance marketplace.

The following is the letter that was sent to those vendors of record in mid-2005 whose products effected timing and the responses that were received:

In Issue 61 the obvious topic for the TDR will be, "It's the (Fuel) Economy, Stupid!" We are planning a story on fuel economy and we would like to include your input in this article.

I plan to poke fun at myself with an exaggerated story about out-of-stock fuel magnets and the Tornado-thingee that does not fit our diameter air intake.

The serious stuff starts with this disclaimer: "Numerous times I have been cited for not including a legal disclaimer prior to an article that discusses a performance gadget, gizmo, or modification. Make no mistake: changing the timing of fuel delivery is a modification that can put your rights to warranty consideration into serious jeopardy. Additionally, timing changes must not adversely affect emissions according to the Clean Air Act, Section 203(a) and EPA Memorandum 1A."

This disclaimer will be followed by Joe Donnelly's "How-To" material on fuel pump timing for better fuel economy. Joe covers the mechanical VE and P700 fuel pumps, taking us up to the advent of electronics.

At this point it becomes subjective with comments from writers, "I think..."

So, I will jump on the band wagon. I think timing (either mechanical advance or electrical) is the magic bullet for Dodge/Cummins owners to consider in their quest for cost-effective mile-per-gallon gains. Have I missed the mark?

Thus, the purpose of this correspondence is to allow you and your company a forum to present any fuel economy data you may have on your VP44 and HPCR boxes. To keep the correspondence on track, I have provided a Question & Answer format below. I would appreciate your responses to these questions.

I received a response from TST Products' Mark Chapple

and MADS Electronics' (Smarty) Marco Castano. Their answers make up the balance of this article.

Is fuel injection timing a "magic bullet" or is the editor off-his rocker?

TST Products' response: I don't see it as a magic bullet, but I believe there is a definite trend. As emission laws get tougher, manufacturers retard timing to reduce NO_x. The reduced NO_x comes from lower cylinder pressures and temperatures, but this is the opposite condition one would want for best fuel efficiency.

MADS Electronics' (Smarty) response: I'm sorry to say, timing alone is not the "magic bullet."

Let me expand.

The mechanical VE and P-7100 injection pumps have a preset and fixed value for the "beginning of the injection stroke." This means that the preset timing is optimal only for a rather narrow RPM/load range of the engine.

Since the introduction of the first "real" emissions regulations (NO_x, HC and PM emissions) all engine manufacturers were forced to introduce electronic engine management. The introduction of electronic control modules provided a much more refined control over the injection timing. Electronic engine management provides the ability for dynamic timing changes throughout the RPM band. Therefore not only RPM, but parameters like engine temperature, boost pressure, intake air temperature, etc., can now be taken into account to adjust the timing of the engine.

Were there no such thing as emissions regulations the electronics could provide the "perfect" timing for the engine. Thus the best possible mileage?

Unfortunately, the world is not a perfect place...

In order to reduce the combustion temperature thus NO_x and PM emissions one simple way is to retard the timing. Furthermore, for the emissions test(s) the low load/low RPM range is weighted more than, let's say, wide open throttle. That means the high load/RPM range is less important from an emissions point of view.

This leads to what's under our eyes or should I say right foot? Detuned/sluggish engines in the 600-2000 RPM range. Range where we use them most! Detuned because of the emissions. Sigh!

This is of course counterproductive from the mileage point of view in a Diesel engine! As you surely know, the diesel engine is most fuel efficient in the lower RPM range; typically the best BSFC is yielded, which happens to be around peak torque.

Then faster the engine gets into the peak torque range then

better its fuel efficiency in the real world. This is where the timing really comes into the picture! Correct timing means an engine that's more willing to gain the revs. Thus we get sooner to the best fuel efficiency range.

Although, the timing is retarded typically on ly 1-2 degrees for the emissions (also Cummins has to make sure to deliver the best possible mileage. What about a new word? Emissions possible mileage?) which leads from my findings to a 1.5-2% mileage loss.

To come to a conclusion. The timing alone gains about 2% mileage. This nets out to nothing that could be measured in the real world! Yet, the timing (engine responsiveness) combined with increased fueling in order to get into the best BSFC range as soon as possible is what really gains mileage!

This is the real reason why most customers report mileage gains with their power modules. They get to the RPM range sooner and can stay longer where the diesel engine is most fuel efficient.

Do you have a mechanical timing recommendations(s) for '89-'93 VE fuel pumps? The expected mpg benefit?

TST: The '89-'03 engines didn't have to meet as strict emissions rules thus the timing was left in a position for fairly high in cylinder temperatures and pressures. Timing changes would have very little effect on mpg.

MADS: No.

Do you have a mechanical timing recommendations(s) for the '94-'98 P7100 fuel pump? The expected mpg benefit? Data?

TST: Timing was retarded more in '94 to meet the NO_x laws thus advancing timing had more effect on mileage. Though we didn't make dyno runs at constant horsepower to measure fuel economy on our 12-valve truck, my log-book mileage appeared to improve by 3 to 5% once we advanced timing from about 12.5 to 15.5 degrees BTDC. This lowered exhaust temperature a bit at a constant power, and made the engine rattle more.

MADS: No.

Please share your timing experiences with the '98-'02 VP44 fuel system and your performance module. The expected mpg benefit? Part number to be used? Settings for best mpg? Data?

TST: The '98.5-'02 trucks with the VP44 pump had even more retarded timing than the '94-'98 trucks to meet an even lower NO_x standard. We used computer tools to change the numbers in the ECM timing tables and again lowered exhaust temperatures and picked up 3-5% fuel economy in our log-books.

MADS: Reported mileage gains with the Smarty S-03 are in the 1 to 3 mpg range. And, although I would like to believe in a 3mpg gain...I have never experienced it personally in my daily driver(s)! I've found that a 1 to 1.5mpg increase sounds more reasonable. There is no such thing as "best" setting for mileage. Everything depends upon driving style and conditions. This is why we strive to deliver to most flexible tuning system possible. "One size fits all" just can not do the trick.

Please share your timing experiences with the '03-'07 5.9-liter HPCR fuel system and your performance module. The expected mpg benefit? Part number to be used? Settings for best mpg? Data?

TST: We ran dyno tests with various timing on our '03 Ram and gained about a 4% improvement in fuel economy at 55mph, up to a 10% gain at 75mph. Book mileage jumped 2-3 miles per gallon on this truck for a 10-15% gain.

MADS: The answer is the same as my response to the question about the VP44 fuel system. The product that should be used in HPCR applications is the Smarty S-06 or SJ.

Your closing comments:

TST: TST has been in the business of increasing power and torque for a decade. Up until 2006 about 90% of incoming started with, "How can I get more of that power and torque stuff?" Then, almost overnight, the question became, "How can I get more mileage out of this big beast?"

Power and torque increases were always easy for us to measure as we test on our own chassis dynamometers. Typically, we would leave one of our test trucks on the dyno for 6-8 weeks at a time, daily trying a program change or parts change, and let the dyno tell us if the engine liked or disliked the change.

My first job in Cummins Engineering in 1966 was keeping track of hundreds of test semi-trucks running without ever changing motor oil. Monthly, I would have to pull oil samples on each of these trucks, record mileage, any oil addition since the last check, and document the results of the oil analysis tests. I started keeping record books on my personal vehicles at that time, recording every event, fuel fill, oil change, new tires, etc. As a part of the personal record keeping, I'd calculate the mileage at each fill and noticed how the mileage constantly changed tank to tank. I've continued this practice to present day with my diesel trucks, keeping Excel spreadsheets to show each tank's mileage, running average, and change in fuel cost. Carefully filling the tank to the top, with the aid of a tank vent kit, still did not eliminate the variation tank to tank. My Excel spreadsheets (and your notepad and pencil) are good for long-term trends, but I view them as consistently inconsistent for short-term evaluations.

With customer requests for better mileage becoming the number one priority, I spent many hours wondering how TST could evaluate fuel economy without burning several tanks of expensive fuel. I recalled my experience in the Cummins Engine research labs where we often monitored the fuel consumption of running engines without the hindrance of an attached vehicle. All engine manufacturers gather data to calculate brake specific fuel consumption (BSFC) in order to compare the relative economy or efficiency of various engines. Typically an engine would be run for several minutes at a constant brake horsepower and the fuel used was measured in pounds. The word brake in this case meant the engine dynamometer which measured flywheel torque and engine rpm such that engine flywheel horsepower could be calculated. A simple calculation could be made with the gathered data by dividing the weight of the fuel used in pounds per hour by the horsepower being generated. BSFC number like 0.350 pounds per horsepower per hour was the end result. A very good engine might run a 0.330 BSFC while a poorer engine might run close to 0.410 BSFC.

I felt finding a BSFC-like number for a Turbo Diesel would be a good way to check the relative fuel consumption. I knew our chassis dyno could be set to measure the horsepower at the wheels. But at what horsepower did we need to run the tests? The TST staff brainstormed the question and decided we needed to determine the actual horsepower it took to move a Turbo Diesel pickup at various road speeds. We took our '03 Dodge Ram out on the Interstate highway and ran it for several miles in both directions while recording instrument readings for air temperature, mph, gear selected, turbo boost, egt, rpm, and rail pressure. We gathered data for road speeds from 55 mph to 75 mph, in 5 mph increments. We then tied that truck to the chassis dynamometer and tried various loads until we could reproduce the instrument readings we took out on the Interstate. This gave us a horsepower value to use in our fuel economy tests for various road speeds. (See figure 1)



Next, we needed a way to accurately measure the fuel used during our testing. While we considered trying to carefully refill the stock Dodge fuel tank after each run, we quickly discarded that idea because it was impossible to fill that tank to the same level each time. We also considered placing a small tank in the bed of the truck that would be easier to refill to the same level each time, but that still left us with the problem of measuring just how much fuel it took to refill the tank. Suddenly it became obvious, let's run the truck using a remote fuel tank that sets on a very accurate scale and simply

weigh the fuel as it is consumed. By carefully weighing a gallon of fuel, we could then determine the number of pounds per gallon. We could then use this pounds-per-gallon number to convert our pounds of fuel used back to gallons for the mpg calculation. This is the procedure that is used by Cummins in official ASE-type testing of big rigs at fleet accounts. We purchased an electronic scale with a digital readout that was guaranteed accurate to one hundredth of a pound and used a transparent five-gallon plastic jug as our fuel tank. We unhooked the quick connects from the truck tank and plumbed them such that the engine would draw and send its return fuel to the plastic jug (See picture below).



Ready to start testing? We thought so. We brought the truck up to 55mph on the dyno and set the truck cruise control to hold the speed. That part worked great. Next we started increasing the load on the dyno until we could repeat the horsepower number we found from the earlier Interstate highway testing. That part worked great too. Then we drove the truck for five minutes at these conditions taking the fuel weight before and after the test. That part worked great too. Well, almost. One of our technicians accidentally touched the five-gallon jug and realized it had become very hot from the engine's returned fuel.

It took about four hours to add 50 feet of copper tubing to our return fuel line. We dropped that copper line into a large cooler and returned the fuel to the plastic jug. We then used a garden hose to run cold city water through the cooler to keep the returned fuel cool. By regulating the city water flow we could maintain the fuel temperature at a usable level.

We were ready to start testing again. This time we were able to repeat the weight readings time after time during the five-minute test. We now felt we had a way to quickly and accurately determine how various engine changes would affect fuel consumption.

Back in 2002-2004 we developed the PowerMax CR for the 5.9 HPCR engine. We engineered a way to vary injection timing, injection duration, and rail pressure on the fly. Of course our motive was different back then; we were after the most power and torque at the lowest exhaust temperature. Now with a new goal of best fuel economy, we started all over again trying to optimize timing, duration, and rail pressure.

First we determined the fuel consumption curve for the stock engine using our new measurement method. (See lower

curve in figure 3.) The mileage numbers from this test were quite a bit better than our record book showed for this truck, but keep in mind that our new test method was steady state only, no starting and stopping. I figured if we could improve the steady state numbers, mileage would also improve on the highway.

To start, we tried the injection timing schedule from the PowerMaxCR that gave us the best power curve. That timing helped fuel economy a bit, but not a significant difference. Over the next few hours we tried many different injection timing settings and selected the ones that gave us best economy from 55 to 75 mph. (See upper curve in figure 3.) We then tried varying the rail pressure while using only the best timing found earlier. Changing the rail pressure didn't help.

We added an "Economy" setting to the PowerMaxCR as a result of these tests. To date, customer experience has been mixed. Some claim big gains like 3 to 4mpg, some report no change at all, while a few claim they lost mileage. How could this be? Looking back, all testing was done on the same truck. The truck was a '03 Quad Cab, 4x4, SRW, long

bed, six-speed manual, 3.73:1 axle, stock BFG tires (LT 265/70 R17). The only modifications to the truck were cab high full length cap, FASS HPFP 95 gph pump, and a South Bend Double Disc clutch. I felt the FASS pump and SBC clutch had no affect on the mileage test, but were needed on the truck for full power testing done separately.

What next? Let's run the rail pressure box but with stock timing. Bigger injectors get the fuel in quicker, so do they help the same as advancing timing? How about a 48RE automatic truck? Is there any difference in the behavior of the '04.5 HPCR engine with its 325hp? I've got a 6.7-liter chassis cab to test. Then there is the 6.7-liter pickup with the terrific new 68RFE six-speed automatic. What? You want me to run an '89, too. It doesn't end, does it.

Maybe next issue!

Mark Chapple
TST Products

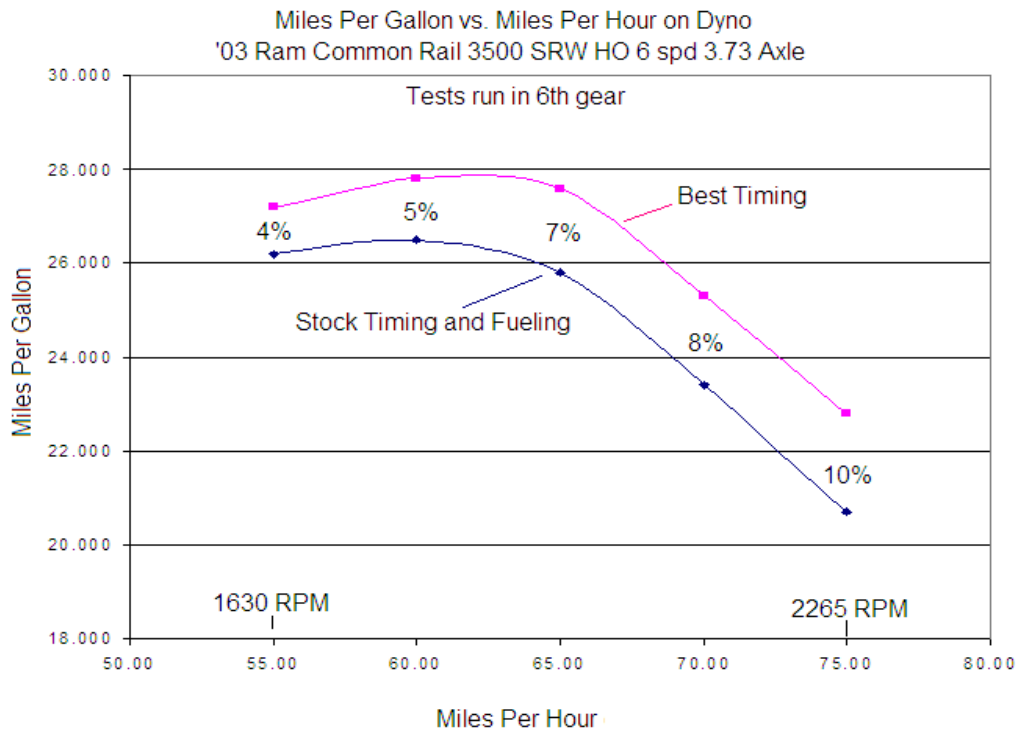

FUEL MILEAGE

The big concern today is fuel mileage, in deference to the high prices we are paying. Some useful information was presented in "The Way We Were" in TDR Issue 47, pages 103-107. That article was a reprint of information from way back in Issue 29, but the concepts are still valid today and more worth reviewing than ever. Most recently, I discussed fuel mileage versus performance in Issue 60, page 90. Fuel is up another dollar or so a gallon since then, so many readers are even more concerned. Let's just briefly hit the high points.

Watch out for unnecessary added weight. It takes fuel to carry or pull more weight. The Third Generation Turbo Diesel in your driveway may be 1000 pounds heavier than your old Second Generation Turbo Diesel was. My '04 has a shipping weight of over 7000 pounds versus 6000 for my '97. The extra 700 pound load of fuel you carry in an auxiliary fuel tank costs a bit of mileage also!

Wind resistance can be increased by added toys such as big tires, poorly designed aftermarket front bumpers, and aftermarket accessories such as brush guards, mirrors and bug deflectors. Winter fuel has a lower heat content (usually measured in British thermal units or BTU) so will often cost 1-2 miles per gallon (mpg). Synthetic or premium lubricants can help mileage a little. Injectors can play a role in improving economy. Owners of the '98.5 to '02 24-valve Turbo Diesels report an improvement of about 1.5 mpg from the Bosch #0432193635 injectors that were originally used on the 275hp rated RV engines. Of course, driver habits remain one of the biggest, if not the biggest, factor in fuel economy.

One personal experience regarding driver habits is worth noting here. Running 79mph on the interstate over long trips used to be normal. However, reducing speed to 72-74mph gained me some mpg, maybe 1 or more.

Moving on from what toys or features on your truck may be hurting, and how your heavy right foot plays a role, let's consider what we can do to the engine itself. Probably one of the biggest improvements we can make is advancing the timing toward "best economy" settings rather than the "best emissions" that the factory has to adopt. Cummins is aware of the trade-offs, and summarizes the effects of moderately advanced timing as these:

- Increased cylinder temperatures and pressure (more power)
- Increased fuel economy
- Decreased exhaust temperature
- Decreased hydrocarbon emissions
- Increased smoke at peak torque
- Increased NO_x emissions.

The hardest emissions parameter to bring down to the EPA legislated levels for diesels is NO_x and that is the culprit behind the retarded timing and the exhaust gas recirculation (EGR) systems that hurt diesel fuel economy so much. In this issue we will focus on ways to advance the injection timing on your Turbo Diesel.

Editor's note: Numerous times I have been chided for not adding the legal disclaimer prior to a writer's article that discusses a performance gadget, gizmo or modification. Changing the timing of the fuel delivery is a modification that "can put your rights to warranty consideration into serious jeopardy. Additionally, the timing changes 'must not adversely affect emissions' according to the Clean Air Act, Section 203(a) and EPA Memorandum 1A."

There you go. If you want the full details of the warranty and emissions discussion you should refer to Issue 60, page 50-52. And the answer to "Why didn't the factory guys do this?" is addressed on page 42.

SETTING THE ENGINE'S TIMING

Timing the Bosch VE Injection Pump ('89-'93 Vintage)

The VE distributor type injection pump came out in the 1970s and was used in the Dodge Turbo Diesel application from '89 up through the '93 model year. This pump has been widely used for diesel engines up to about 33 horsepower per cylinder output (about 200 hp for six cylinder engines). It weighs only about ten pounds and is relatively compact in dimensions. It is moderate in cost to buy and to repair. It is lubricated by diesel fuel only, so it is very sensitive to fuel quality. Its maximum design output fuel pressure is 700 bar (10,150 psi). It uses a single high-pressure piston, so it has fewer parts than many other designs of pumps. Idle speed, maximum speed, and maximum fuel delivery quantity are all externally adjustable. Tamper-resistant caps or seals are put over the adjustment screws at the factory.

The VE pump is limited in fuel delivery volume and pressure, compared to the pumps used in later model Turbo Diesels. The volume limitation became important when greater horsepower was sought. The low (10,000 versus 17,000 psi) pressure meant that new emission regulations for 1994 could not be met. To meet these EPA regulations, higher pressure was needed to bring in enough fuel quickly, during the time period when it would burn most efficiently and produce the least smoke. Higher pressure also improved atomization, especially if larger injectors were used to increase fuel delivery for more power. In the early 1990s, these concerns were coupled with problems from the advent of low-sulfur fuel, and with the concerns about poor fuel quality or cleanliness. These issues made it clear to the manufacturers of diesel engines that they had to discontinue use of the VE pump for our Turbo Diesels and for other over-the-road applications.

There are official tools and procedures for setting the timing of the VE pump. Many years of working with these pumps on Dodge applications have resulted in some "quick and dirty" procedures that you can use on a try-and-fit basis. You can try small incremental positioning (turning) of the pump to see what effective timing works best for your truck. If you want to take the pump timing about as far advanced as you would want, for good performance and economy, the result will be around 5/8" to 3/4" clearance between the air-fuel control module (afc) and the cylinder head, about a finger-width. Advancing the pump too much (moving the top toward the

head) gives white smoke, but not the amount of engine fuel knocking or rattling that you would get from advanced timing with an in-line P7100 pump. Better mpg may occur with advancing the VE pump timing slightly from stock. Retarding the pump timing will generally result in lower engine power.



A Bosch VE pump on a Cummins B engine, with a finger showing the clearance between the AFC module and the cylinder head.

If you decide to use the “finger clearance” method, first look closely at the pump flange to the outside of the outermost mounting stud and nut. You should find a chisel notch on it, and a corresponding notch in the gear housing. These marks serve to indicate the “factory” timing setting. To rotate the pump and advance the injection timing, you need to loosen the three 13 mm headed nuts and the injector line nuts at the back of the pump (so you won’t twist the lines and strain them). The pump will resist turning until the nuts are loose enough, because of the fiber mounting and sealing gasket that can be seen in the photos. The Snap-on Blue Point SP144 wrench helps greatly in removing the two hard-to-access pump mounting nuts. The Snap-on flare nut crow’s-foot helps to loosen the injector line nuts. It should be 16 mm (5/8”, part number FRH200S) or 17 mm (part number FRHM17).



Engine side of a VE-pump style Cummins gear housing.



Close up view of the VE pump mounting area of the gear housing with the housing timing mark and the pump-to-housing gasket.



Snap-on flare nut crow’s-foot and pump mounting nut wrench.

This article was an update of Joe’s Issue 35, page 20-21, article on the Bosch VE fuel injection pump.

Timing the Bosch P7100 Injection Pump

The Bosch P7100 in-line injection pump is heavy (about 45 pounds), large, relatively expensive to buy and to repair, and originally intended for much larger engines than our little 5.9-liter Cummins B series. This model of pump ended up on the ‘94-‘98 12-valve Turbo Diesels. Dodge and Cummins were able to increase power ratings without stressing the capabilities of the pump. They could meet the new, more stringent emissions requirements of January, 1994 because this pump had the fuel volume and especially the pressure they needed. This pump is intended for original equipment manufacturer’s applications up to 94 hp per cylinder (563 hp for six cylinders) and produces fuel pressures up to 1150 bar (16,675 psi). Like the VE pump, it is fully mechanical in operation, but there the similarity ends.

The P7100 pump is an in-line design pump. This means that the injector for each cylinder of the engine is fed by a dedicated high-pressure plunger-and-barrel assembly in the injection pump. These plunger-and-barrel assemblies are arranged in a linear fashion, not a circle. The fuel is pressurized by the up-and-down stroke of the plunger, brought about by a camshaft eccentric (see Figure 4). Thus this pump has a camshaft that is engine-driven, and each plunger has a roller-lifter type of actuation. Fuel delivery quantity is controlled by rotating the plunger. This action

changes the exposure of the fill/spill port of the barrel to the fuel gallery, to determine the amount of fuel that will be “trapped” and pressurized. (See Figure 5). The six plungers (for a six-cylinder diesel engine) are connected to a fuel control “rack” which extends to the governor so that the governor can control the fueling of all six plungers equally and simultaneously.

For different power ratings, Bosch uses different design plungers and barrels, and different camshaft lobe profiles. For our Turbo Diesels, there are three basic internal sizes of P7100 pump: The 160hp is the smallest; the 175-180hp is somewhat larger, and the 215hp version is one of the largest P-pumps available. For comparison, using Turbo Diesels that are otherwise similar in level of modification, The 160hp pump would allow about 320-340hp at the wheels, the 180hp pump would give about 370-400, and the 215 pump would give 500-540hp. All of these pumps use versions of the Bosch Model RQV-K governor.

The P7100 uses engine oil to lubricate the governor and bottom end of the pump. Of course, the fuel plungers and barrels, as well as the delivery valves, still rely upon diesel fuel for their lubrication, so it would be a serious mistake to think that any type of diesel fuel is adequate because the pump uses engine oil as a lubricant. The pump is generally very reliable, and being fully mechanical in operation, it is relatively easy to diagnose and to modify.

Back in 1999 when I was taking a lot of long trips, I found that 15 to 15.5 degrees of injection pump timing advance on the 215hp engine gave the best fuel economy at about 2000 rpm. I ran as much as 19 degrees and did not have any headgasket or starting issues.

To set the timing of the P7100 pump, you need precision tools and all fuel system internal parts must be kept scrupulously clean. You need Miller MLR 6860 pump timing tool kit and a Snap-on Blue Point SP504 plate style gear puller (or equivalent). When you remove the #1 delivery valve, do not touch it dry with bare fingers. Use a clean telescoping stalk/magnet and keep it covered with clean diesel fuel.



T5. Miller MLR-6860 P7100 pump timing tool kit. At the left is a magnet on a telescoping “stick.” To its right is the dial indicator with the stem extension below and to its right. To the right of that is a timing pin with a steel tip epoxy glued onto it. The special splined socket is at bottom right, with the splined end resting on a block of wood. At top center is the adapter that holds the dial indicator and screws into the top of the pump barrel. At top right is an engine barring tool that plugs into the aluminum block adapter plate and meshes with the flywheel teeth.



T6. The Snap-on SP504 gear puller with M8x1.25x40 bolts and the home-made pump shaft turning tool at right.

The P7100 injection pump cannot be simply rotated so the top is closer to the cylinder head. Its mounting ears do not have elongated slots, and the back end of this very heavy pump is supported on a flat pedestal mounted to the engine block. You must pull the drive gear and then rotate the pump shaft. Pulling the gear inevitably results in a shock as the taper fit “pops,” causing the pump shaft to jump out of time, in the retarded direction—but how much it jumps (rotates) varies with each time it happens. That is why you simply CANNOT use a shadetree trick like popping off the gear, turning the crank a little, and replacing the gear. You just cannot tell where the pump timing “went” without the dial indicator.

We will go through the principles and procedures for setting P7100 pump timing, but the cost of the tools and the advanced type of effort involved make it neither realistic nor cost effective for most Turbo Diesel owners to do this at home.

Principle behind mechanical fuel injection timing

In a four-cycle gasoline engine, the distributor and the camshaft both turn at one-half crankshaft revolutions per minute (RPM). Since diesel fuel is ignited upon injection, a fuel injection pump for a four-cycle diesel engine also rotates at one-half engine rpm. The 36-tooth crank gear turns the camshaft gear which has double the number of teeth (72) on it that the crank gear does. In turn, the cam gear turns the Bosch P7100-pump drive gear which also has 72 teeth so the pump will inject fuel every second revolution of the crank (or top dead center position of the piston). Timing of the pump and this injection event is controlled by the design of the pump and the rotation/position of the pump shaft (with its eccentrics that control the fuel “squirts” to the injectors) versus the position of the crankshaft (and hence the piston). The pump gear is solidly attached to the pump shaft by a Morse taper fit similar to the taper fit that holds the drill chuck to the spindle of a drill press. To advance the pump timing, you need to pull the gear off the pump shaft, rotate either the gear or the shaft, and clamp them back together so that the pump shaft reaches a point where the fuel injection squirt comes sooner relative to the movement of the crankshaft and piston.

Procedures to re-set the timing with the P7100 pump.

1. Install a dial indicator so you can track the fuel injection event within the pump. Install the engine barring tool in the flywheel and rotate the engine crankshaft until the needle indicates the lowest point of the pump plunger. To get to the plunger, you have to remove #1 injection line, [right hand arrow in photo T7] use a special splined socket to remove the "tower" on the #1 pump barrel, and then use a magnet-on-a-telescoping-stick to pull the delivery valve and its steel casing (about 5/8" diameter) out of the pump barrel. [see photo T8] Then you thread on a special holder for the dial indicator, and install the indicator so the measuring stem is on top of the plunger. [see photo T9]



T7. A Bosch P7100 pump on a Cummins B engine, with arrows pointing to the oil filler tube/cap, and to #1 injection line and pump barrel.



T8. Delivery valve parts removed from #1 injection pump barrel assembly in order to set timing.



T9. Dial indicator installed in #1 barrel of a P7100 injection pump.

2. Rotate the engine crankshaft to TDC for #1 cylinder and make sure it is the TDC of injection (with a four cycle engine, one is injection/firing TDC and the other TDC is "overlap" of the exhaust and air intake events). The correct TDC will have #1 valves closed and both valves for #6 cylinder will be slightly open.
3. Compare the amount of plunger lift at TDC to timing in degrees using the table on page 105 for the specific version of your P7100 pump. Now you know what the timing is before you reset it.
4. While the barring tool prevents the engine from turning, remove the 30-mm hex nut and washer from the pump shaft. The nut is behind the oil filler tube (left hand arrow in photo T7, and bottom left in photo T10), and to access it you have to unthread the oil fill pipe from the base, and unthread and remove the base from the engine gear housing cover (T10).



T10. A Cummins gear housing, front side, with the oil filler tube at yop left.

- Use a puller (Snap-on SP504 or similar) to “pop” the gear (photo T11) loose from the tapered pump shaft. If you watch the big and little dials of the indicator, you will see how much the pump timing retarded on this occasion. Use of the puller is illustrated on a CP3 pump and gear in Photo T12. (Notice that the CP3 uses a small 36 tooth gear and thus spins at crankshaft speed, not camshaft speed!)



T11. A Cummins B gear housing with a P-pump drive gear, washer, and nut.

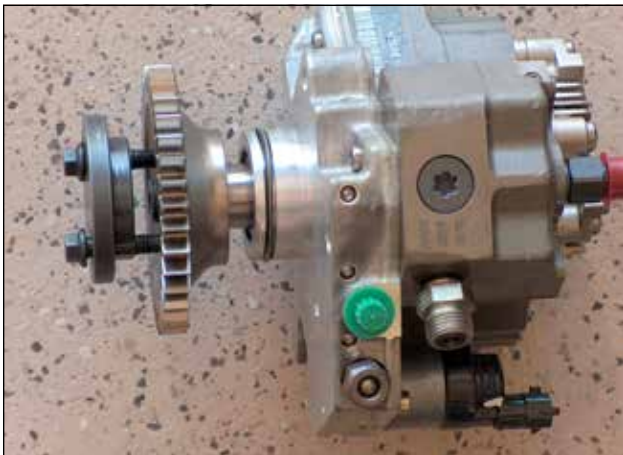

T12. Use of the SP504 gear puller is illustrated here with a Bosch CP3 pump.

- Now you need to turn the pump shaft so the dial indicator gives the plunger lift specification you want, corresponding to the desired timing. You can do this by reinstalling the pump gear and snugging the nut, then using the barring tool to turn the engine and hence the pump. If you are lucky and go to just the right amount of lift beyond what you want, when you pop off the gear, the pump will jump (retard) to the lift you want. The jump should be small if the gear was on just enough to turn the pump, but not very tight. Then you turn the engine back to TDC while leaving the pump gear loose so the pump stays at the timing you want. Use Mopar non-chlorinated brake cleaner #4897150AB to gently spray the taper fit of the gear and shaft while wiggling the gear with a long M8 x 1.25 thread bolt so all the taper is cleaned. Don't spray hard and blow oil out of the bearing on the pump shaft just behind the taper! Then, gently blow-dry the taper with clean compressed air. Push the gear onto the shaft, install the oiled washer and nut, torque to 144 ft-lb.
- Here is a tip that may be worth trying if you are going to set timing a number of times: you can weld a 3/4" fine thread nut onto an extra P-pump nut, and run a bolt in to jam against the end of the pump shaft. (Photo T6, right side, page 103). Then you can turn the pump to set plunger lift, and hence timing, with this tool and leave the engine at TDC.
- Check the green O-ring on the “tower” for abrasion and replace it if necessary (Bosch #2 410 210 033). A worn O-ring seal will allow fuel to leak out during operation. Put a thin film of grease on the O-ring and the surface of the pump barrel and tighten the the “tower to 29 and then 85 ft-lb in a smooth motion.
- Re-assemble, tightening injection line nuts to about 25-28 ft-lb.

The table below shows injection timing in degrees versus injection pump #1 plunger height (lift) for different Bosch P7100 in-line injection pump used from '94 through the first half of the '98 model year. The engine's data tag will show the stock timing in degrees and the plunger lift can be measured. Using the table you'll find the lift necessary to set the timing to achieve better fuel economy. Over time, we have found that about 15.5 degrees of timing gives most folks the best fuel economy but a bit less mid range torque than the stock, lower, timing settings. Your engine CPL can be found on the data tag that is riveted to the driver's side of the front gear case. The table shows timing in degrees versus millimeters of cylinder #1 pump plunger lift:

Deg.	'94-'95 P7100 injection pumps		'96-'98 P7100 injection pumps	
	Automatic	Manual	Automatic	Manual
12.5	4.2	5.7	4.21	4.89
13	4.3	5.8	4.29	4.98
13.5	4.4	5.9	4.37	5.07
14	4.5	6.0	4.45	5.16
14.5	4.6	6.1	4.53	5.25
15	4.7	6.2	4.61	5.34
15.5	4.8	6.3	4.69	5.43
16	4.9	6.4	4.77	5.52
16.5	5.0	6.5	4.85	5.61
17	5.1	6.6	4.93	5.70
17.5	5.2	6.7	5.01	5.79
18	5.3	6.8	5.09	5.88
18.5	5.4	6.9	5.17	5.97
19	5.5	7.0	5.25	6.06
19.5	5.6	7.1	5.33	6.15

Timing the VP44 Fuel Injection Pump

The Cummins 24-valve engine was designed to meet the tighter EPA federal emissions regulations of January 1998. An essential feature of this engine was the use of electronically-controlled fueling events. The Bosch VP-44 injection pump (see Figure 10) was already in use in Europe for smaller engines, and was fully electronically controlled with regard to injection timing and fuel quantity. This pump delivers fuel at high pressure (1000 bar or 14,500 psi), almost as high as the P7100, to assist in meeting emissions requirements. The size, weight, and cost of the pump are much lower than the P7100, more like the VE pump. However, the new VP44 pump differs in several important respects from the older pump. In order to develop the higher pressure it produces, it uses three radial pistons to pressurize fuel instead of one axial piston. While the engine mechanically rotates the pump, as with a VE pump, the fueling commands are all performed via on-board computer (fuel pump control module). While there are different Woodruff keys for the VP44 pump shaft, you cannot advance the pump timing with them. The computer will normalize the timing to specification.

As soon as the 24-valve Cummins engine appeared with our Turbo Diesels, in January 1998, some owners of the new version of the Cummins B series engine began complaining that they wanted more power. Several aftermarket companies addressed the problem and found that electronic solutions were the most straightforward to develop and install. Some of the power-adding products also added timing advance. The VP44 injection pump is mechanical but is surrounded by three computers. First is the Dodge computer on the firewall, second is the engine electronic control module (ECM) on the driver's side of the engine, and third is a computer on the top of the VP44 pump itself. The

ECM has proprietary software controlling the fueling parameters, and the fueling commands are sent to the VP44 computer through CAN-BUS communication protocols. The electronic enhancements made by aftermarket firms have used one or more of the four techniques listed below:

1. Intercept the CAN-BUS communications to the VP44 computer at the multi-connector that plugs into the pump. This process entails unplugging the connection, and putting in a Y-connector that goes to the aftermarket "black box" computer. This add-on computer then replaces some commands from the ECM with new ones. One brand (example) that uses this technology is the BD Plug-n-Power.
2. Add new instructions along the CAN-BUS using the data link/diagnostic connector at the engine wiring harness. This connector is used by Dodge and Cummins technicians to access the ECM for engine diagnosis, and to reprogram the ECM. The Edge Products EZ box uses this system, and their Competition Box uses both this technique and Technique #3.
3. Intercept the fueling signal coming out of the VP44 computer that holds the fuel solenoid of the pump closed. This signal determines the time duration that high pressure fuel is available to the injection line and injector. The insulation of this wire is pierced by a Scotch-Lok or similar connector so the add-on aftermarket computer box can receive this signal and add another immediately afterwards to hold the solenoid closed longer. The percentage of the original signal's time duration that is added to it by the aftermarket computer box will determine the power increase. This technique was introduced by Blue Chip, then followed by a similar approach from TST, and later Edge Products.
4. Reprogramming the ECM fueling and/or timing advance curves.

Techniques 1, 2 and 3 require an additional wiring harness to the manifold absolute pressure (MAP) sensor on the side of the cylinder head at the intake plenum, if they are to provide large power (fueling) increases. The ECM generates defueling commands when turbocharger boost goes too high (reportedly, over 20.5 psi). The aftermarket computer harness puts a Y-connection into this harness at the MAP sensor. The box intercepts the boost signal and replaces the signal going to the ECM with an adjusted voltage that indicates to the ECM that boost is within the acceptable range, even when higher boost is actually present. In this way, sufficient boost becomes available to burn the additional fuel efficiently.

Add-on "boxes" that use Technique 3 take the engine rpm and ECM-generated fueling level signals from the pump wire. Boxes that receive CAN-BUS signals, including the Edge Comp box that uses both Techniques 2 and 3, take rpm and fueling commands from signals along the CAN-BUS.

Electronic power enhancement "boxes" that also add timing

include, among others, the Edge Mileage Max and the Juice module with Attitude gauge and control readout box.

The Smarty programmer gives the option of adding timing in its re-program of the ECM (Technique 4).

Timing the High Pressure Common Rail (HPCR) Engines

With the HPCR system, timing is electronic. The pump does not "squirt" fuel at the proper time into a single injection line. High pressure fuel is available at all the injectors all the time the engine is running. The injectors are opened and closed electrically when the engine control module (computer, ECM) commands. There is a mechanical timing sensor on the market that basically moves the crank sensor a little. However, it cannot move much from stock position or the cam to crank sensor alignment will be outside of specifications allowed by the ECM and the engine will not start or run. Significant timing changes must be made electronically, either by a remote box or through ECM programming.

Electronic power enhancement "boxes" that add timing include, among others, Edge and TST boxes. The Edge Mileage Max and the Edge Juice module with Attitude gauge and control readout box. The TST PowerMax-CR allows the user to select the default additional timing, or to add further timing advance in increments of 3 degrees.

The Smarty programmer gives the option of adding timing in its re-program of the ECM. In addition to the default timing increase, the user can select additional increases in the options menus of the Revolution and TNT software packages.

Editor's note: TDR writer Doug Leno has done extensive research on performance modules for the '03-'07 5.9-liter HPCR engines. His work is chronicled in TDR Issues 45, 47, 48, 49, 51, 53 and 57. When asked about fuel mileage (rather than performance) he referred me to his comments in Issue 51, February of 2006.

Doug Leno's Conclusions

- Depending on driving conditions and style, fuel economy improvements on the order of 10% can probably be obtained with a combination of pressure and timing advance. Products offering this approach include the Banks Six Gun, the Quadzilla Xzillaraider, TST Products' PowerMaxCR, and likely (though I haven't tested them) the towing programs offered by the various downloaders from Bullydog, Pacific Performance Engineering, ATS, Smarty and others.
- Traditional pressure modules, even without a connection

to the cam/crank sensors or the CAN bus, probably yield some fuel economy benefit, but not as much as a true pressure/timing enhancement will.

- Timing only, as provided by the TST PowerMax CR (power level 1) will also improve fuel economy. However, realize that it requires discipline to use such a powerful module set at only 25 horsepower gain over stock!
- Never install a power enhancement from any manufacturer without addressing other areas of the truck that may require attention in order to use the additional power. In particular (and most important) you must install an EGT gauge (pyrometer) and keep pre-turbocharger exhaust gas temperatures under 1350°.

Joe Donnelly
TDR Writer

TST Products
812-342-6741
www.tstproducts.com

Edge Products
888-490-3343
www.edgeproducts.com

Bob Wagner and Associates
888-225-7637
www.smartypower.com
www.madselectronics.com

SO YOU WANT FUEL ECONOMY

PART THREE - HOW TO DRIVE

HOW-TO-DRIVE

by Robert Patton

As the TDR editor, I get recurring questions from new Turbo Diesel owners: "How should I drive a Turbo Diesel for the best economy?" And, "How do I use (do I need) gauges?"

This becomes a "How to" question for me: How to balance information that has been presented to long-time TDR members, while covering the basics for the first-time owners? The answer: summarize/reprint the old and update with new and relevant information. Let's break this article down into a fun-to-read format: something old, something new, something borrowed, something blue (can you tell that I recently returned from a wedding?).

Something Old

Something old: We're going back to Issue 20 to reprint information specifically about how to drive using Cummins' engine performance curves.

To ask the TDR for advice on how to drive is dangerous. I have earned many fast driver awards (you know, the citations handed out by the state highway patrol) and my answer is that faster is better. First, to specifically answer the question on first or second gear for a no-load smooth start, I use second gear. The '98 Owner's Manual is vague on the use of second gear starts. The manual states, "For improved clutch life all five forward gears should be used." and further, "You should use first gear when starting from a standing position if under a heavy load." It doesn't specifically state "do not use second gear."

Perhaps the cliché, "do as I say, not as I do," is a fitting introduction to our article on how to drive.

Our search for the engine's "sweet spot" is as simple as looking at a sample torque curve. For purposes of discussion, we will use the '94/'95 175 horsepower engine as used with the five-speed transmission. To fully understand the graph, we will introduce a technical term, Brake Specific Fuel Consumption, as the BSFC values (and guidance from Clessie Cummins' sidebar) will show you (on paper) how to drive.

Brake Specific Fuel Consumption

In layman's terms, brake specific fuel consumption is the efficiency of an engine. BSFC is simply a value that helps us describe the engine's ability to convert fuel into horsepower. BSFC tells you how much fuel it takes your engine to produce each horsepower. The lower the BSFC the better! Here is the equation to convert BSFC into a number we can understand, fuel consumption (gallons/hr) = (Bhp × BSFC) ÷ 7.1 lbs/gallon fuel.

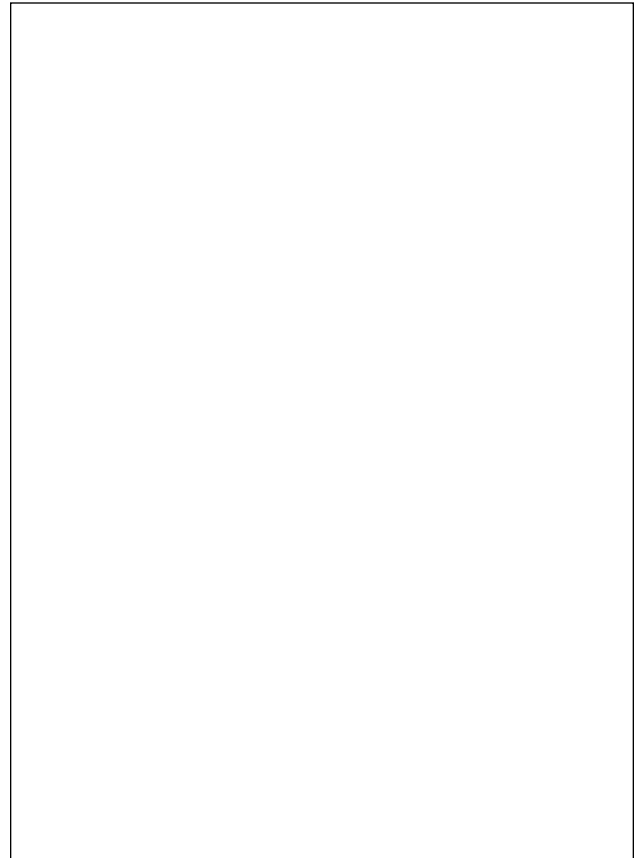

For example, let's look at the BSFC for the 1994/1995 175 horsepower/420 torque five-speed engine. The BSFC is at its lowest at 1500/1600 rpm. The value is .330. If you were using full horsepower at 1500 rpm the mathematic fuel consumption would be Gallons = $(120 \times .330) \div 7.1$ or 5.57 gallons per hour. Can you equate gallons per hour to miles per gallon? Certainly, you can check your tachometer/speedometer to see how "fast" 1500 rpm is in miles per hour (Approximate answer for a pickup with a 3.54 rear axle ratio is 53 mph). But the exercise of equating theoretical gallons per hour to miles per gallon is futile. How often do you travel at full throttle/1500 rpm? The point of the exercise is to show where fuel economy is best, at lower rpm ratings.

What does this mean to you? I hope you've learned from the efficiency exercise that it would be best to put your engine on cruise control at a speed corresponding to 1500/1600 rpm. At 1500/1600 rpm you've got the torque peak of the engine available to keep your speed constant as you encounter a grade. Speed drops off below 1500/1600 rpm, you had better downshift because it's all "downhill" (backside of the torque curve/lugging) from there. You've obviously exceeded the maximum torque produced by the engine and multiplied by the gearbox/rear end ratio of the load you're trying to propel.

Is it possible to cruise at 1500/1600 rpm? On most highways, to avoid being run over by traffic you'll have to exceed the 1600 rpm setting. But, we've encouraged you to seek 1500/1600 rpm for the best engine efficiency and mph. Now you know why my two favorite questions for a low mpg complaint are "How fast do you drive?" and "What is your rear end ratio?" Hmm... low mpg trouble shooting, sounds like a future article. Or, is it simply a matter of driving at a lower rpm/better BSFC number?

For the older truck owners, let's reference the performance curve of a First Generation, 12-valve engine with the Bosch mechanical VE style fuel pump, rated at 160 horsepower/400 torque. Below is a reprint of this graph from Issue 29 and our discussion of volumetric efficiency and brake specific fuel consumption. Note that this engine's best BSFC number was at 1600 to 1800 rpm with the best value of .340 at 1700 rpm.

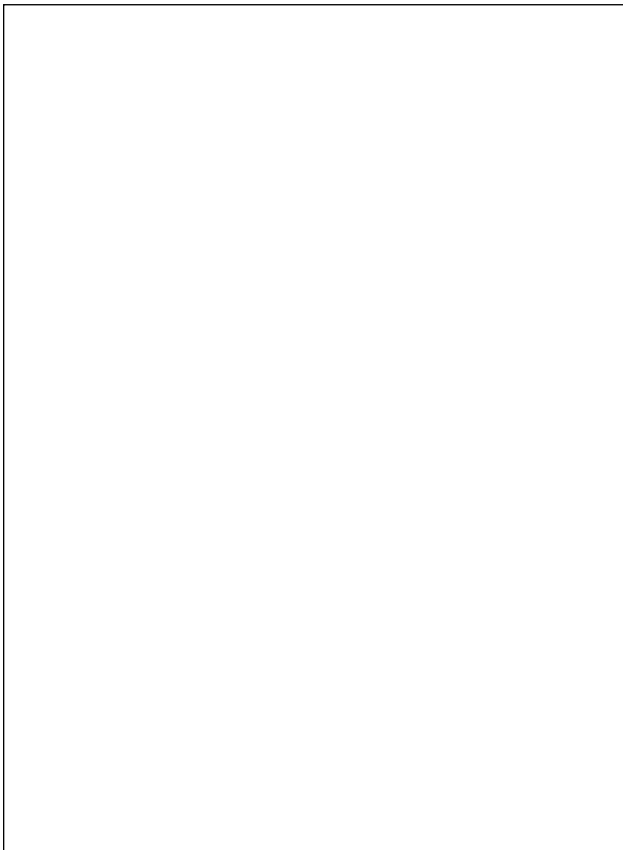

Did you notice the lowest BSFC occurs at the same rpm as torque peak? Coincidental? I don't think so! Both are determined by the engine's ability to completely fill, compress, combust and exhaust air. Again, Issue 29 has the complete story on the volumetric efficiency/BSFC relationships.

Something New

Something new: Lest we get caught in the old routine of the Editor recounting the old engine performance curves for 12-valve engines, we need new and current data! A valid concern, here is the story.

The 24-valve engine is an entirely different story. In Issue 29 we published preliminary (October 14, 1997) performance curves from Cummins on the soon-to-be-released 24-valve 215 and 235 hp engines. At the close of the Issue 29 article we noted, "We will work with Cummins to source the complete engine data sheets showing horsepower, torque, and brake specific fuel consumption."

Guess what? The data exists, but it does not exist. Let's trot-out the *preliminary* performance curves that were used in Issue 29 and then we'll explain the lack of data for the 24-valve engine.

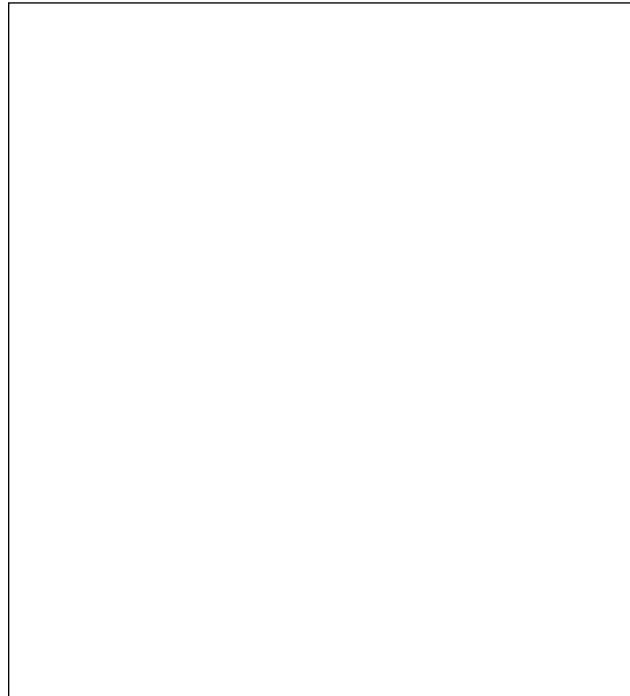

Chart Evaluation

Where is the gentle sweeping torque curve? What happened to volumetric efficiency? Note the preliminary BSFC curve. Let's investigate further.

Electronic control of the Bosch VP44 fuel pump is the key to the 24-valve engine's ability to meet the '98 emission standards. The VP44 electronic module/black box brings computer control to the engine. The computer control allows for infinitely variable timing.

Electronic control, variable timing, variable fuel maps, a free-breathing 24-valve cylinder head – can the engineers custom tailor the BSFC curve, as they can the torque curve, to produce a straight line?

The answer is affirmative. Thus, instead of the preliminary fuel consumption curve, the final Cummins data on the 24-valve engine is not a single curve – rather a collection of fuel maps that differ based on timing, engine load, throttle position, etc. The data is, at best, confusing. Unfortunately, we are left with the preliminary data from Cummins, which, at the time, was their best approximation of fuel consumption.

With the explanation/understanding of the 24-valve's *approximate* fuel curve, we can still use it to help us *approximate* 24-valve fuel economy. It is *not* coincidental that BSFC was lowest/best at the same rpm as the best volumetric efficiency and peak torque. The physics to produce torque peak requires the greatest cylinder filling or volumetric efficiency. But, the 24-valve engine's torque curve is a straight line. However, volumetric efficiency is *still* a mechanical function (crankshaft, connecting rods, pistons, camshafts, rocker arms and valve-train); thus the resulting *preliminary* 24-valve engine's BSFC curve is still an ever-so-slight upward sloping curve.

Fuel Economy/Gearing Debate

Close inspection of the respective 12-valve and 24-valve BSFC curves reveals that the BSFC has moved to a higher rpm! The preliminary data on BSFC for the early 215 and 235 horsepower 24-valve engines shows the lowest numbers to be at 2000 rpm (.334)! The numbers are on par with a 1600 rpm BSFC on the 175 and 215 horsepower 12-valve engines of .330/.334.

Using BSFC numbers, perhaps you would want to gear the 24-valve engines with the higher 4.10 ratio to let the engines rev-out to a 2000 rpm/60 mph cruise speed. Or, are we again splitting hairs between the 2000 rpm/.334 number and the 24-valve engine's 1600 rpm/.337 number? This debate – as well as the debate over lost fuel mileage with the new 24-valve engine – will continue. The figures don't lie and I don't know the answer. Jim Anderson commented on the "4.10 gets better mileage than the 3.54" phenomenon in Issue 27, page 74 and again in Issue 31, page 90. The topic has been debated at many open house events, too.

My experience with my '99 2500, 24-valve truck, 3.54 ratio, automatic is that my mileage is less by about one mpg than my '96, 3500, 12-valve truck, 3.54 ratio, five-speed. Oh, did I mention I drive the '99 truck faster than the old '96? Ah... but the '96 dually was heavier by 600 pounds. Apples and oranges? Does it matter? I'm very pleased with the mileage of the '99 truck.

Something Borrowed

From the BSFC curves we can determine the engine's ideal cruise rpm. To seek a lower cruising rpm is sound advice. Couple the low rpm with Mr. Cummins' experience (sidebar article) with a reasonable exhaust gas temperature of 600° or less, and the fuel economy picture becomes very clear. However, it takes a series of gear changes to get up to travel speed, the tarmac is not a pancake flat surface, and the wind and weather can play havoc with our quest for fuel mileage.

The caution to cruising at a lower rpm is the opportunity for the exhaust gas temperature to skyrocket on a grade or against a head wind. The benefits of an exhaust gas temperature gauge are discussed in the following commentary by Bruce Mallinson. Bruce is the owner of Diesel Injection, Pittsburgh, PA, phone (724) 274-4080, and has previously written for the TDR. Something borrowed... the following text by Bruce Mallinson:

Common Sense/Exhaust Gas Temperature

When running at the lower rpm there is less airflow through the engine. If exhaust gas temperatures – read, your right foot goes through the floorboard for more than 5-8 seconds while trying to maintain the low rpm/high gear cruise speed – moves to the danger zone (1000° for engines when the temperature sensor is installed after the turbocharger, 1250° for the sensor in the exhaust manifold prior to the turbocharger. Interesting note: aluminum pistons, as used in your engine, have a melting point of approximately 1250°. Granted the pistons are cooled by a spray of oil from the underside, but exceed the 1250°/1000° caution for any length of time and you'll understand what "meltdown" means.), then downshift to pull air through the engine and cool the exhaust temperature.

Common Sense/Turbo Boost

We can use a vacuum gauge on an automobile to monitor the air/fuel being sucked into the engine. The less the vacuum, the fewer miles per gallon of fuel. For our Turbo Diesel we can use turbocharger boost to check the air being forced into the engine. The greater the boost, the fewer the miles per gallon. The TDR talked extensively about turbochargers, boost, boost specifications and an engine "check-up" in Issue 17, pages 48-49. My summary of the two pages of text: Turbo boost is simply compressed air produced by the turbocharger and forced through an air-to-air charge air cooler. Then the compressed air goes into the intake manifold to be delivered to the combustion chamber. Without a boost, your truck is dead. It takes a tremendous amount of oxygen to burn diesel fuel. The only way the engine will run without turbo boost is at idle or slightly above idle. The truck will move along in first gear with light throttle. Anything over that will result in horrendous black smoke (unburned fuel) from the exhaust pipe.

Every turbocharged engine should have a turbo boost gauge. This is the most important gauge on the instrument panel because it lets you know how much power you're using, and it also lets you know that the engine is getting the proper amount of oxygen from the turbocharger.

On your Turbo Diesel engine there are 14 gaskets, eight hose clamps, four hoses, one O-ring, and one aluminum air-to-air charge air cooler (it resembles a radiator and is welded together). If any of these items fail, the compressed air being produced by the turbocharger will be vented into the atmosphere and the EGT will skyrocket. If the EGT gets too high, a piston will fail or the engine will have a meltdown.

As a rule of thumb, one pound of boost is equivalent to about 10 flywheel horsepower, so when you're pulling a mountain you can control how much power (fuel economy) you're using simply by watching the boost gauge.

The boost gauge and the pyrometer are great diagnostic tools for determining power losses. If your boost is low and the pyrometer gauge is running high, it's telling you that turbo boost is being lost. If the boost is low and the pyrometer, or EGT, is low, then there is likely a fuel restriction.

Something To Remember

It takes fuel to make turbo boost, and it takes boost to control the exhaust gas temperature. If you call a dealer with a power problem, the first question from the shop to the owner should be, "What is the boost pressure and the EGT when pulling a hill?" If you can't answer those questions, then you will be spending a lot of money on troubleshooting. Reference the accompanying chart for the specifications.

12-valve engines ('94 - '98), automatic transmission
160, 175, 180 horsepower 15-18 psi

12-valve engines ('96 - '98), five-speed transmission
215 horsepower 21-23 psi

24-valve engines ('98.5 - current), automatic or manual
215, 235, 245 horsepower 20-22 psi

One more important aspect of the turbo boost gauge: I'm sure you've noticed how difficult it is for your pickup pulling your fifth-wheel to buck a strong head wind. It is possible to have an EGT of 1300° and be on level ground while pushing through a 35 mph head or side wind while trying to maintain 60-70 mph. Normally, let's say that your truck requires 11 pounds of turbo boost to maintain your average cruising speed on the level without head wind. Now with the 35 mph head wind, it takes 22 pounds of boost and a high EGT to maintain the same speed. What should you do?

Slow Down And Shift

The first thing the driver should do is slow down and shift out of overdrive and into direct gear. Much more horsepower goes to the rear wheels in direct than overdrive. At the lower speed less boost is required, the EGT will be lower, the fuel mileage will increase and the wear and tear on the engine will be much less. Head wind or side wind is an engine and fuel mileage killer. Adjust the speed by trying to keep the boost gauge as low as possible along with maintaining a reasonable speed until you are out of the wind.

When the wind is at your back, you can speed along using little boost; the EGT is low at 600-800° and the fuel mileage is great.

Learning to drive with the boost gauge and pyrometer gauge will increase your driving pleasure, increase the fuel mileage and also increase the engine's life. My shop, Diesel Injection, can help with a wide selection of turbo boost, EGT, and temperature gauges.

Bruce Mallinson
Diesel Injection of Pittsburg

YOUR TRUCK AND THE BOOST TREADMILL

Boost specifications: The TDR magazine has often been criticized for being too technical, I should take an opportunity to explain why the maximum boost specification is important to an owner.

I searched the archives for an easy-to-understand article on turbocharger boost. The following is a quick review of turbocharger basics.

TURBO BASICS

The principle behind a turbocharger is simple: get more power from the engine without increasing the engine's size.

To increase engine power, you start by adding more and more fuel. But soon, you'd be wasting fuel, because the fuel needs air to burn. Technically, it needs the oxygen in the air to burn.

In a naturally aspirated engine, the air is pulled from the atmospheric pressure surrounding the engine into the combustion chamber on the intake stroke of the cycle.

At sea level there are .016 pounds of oxygen per cubic foot. At higher altitudes, air is thinner and there's less oxygen. For example, at 5,000 feet there's only .010 pounds of oxygen per cubic foot. So, at higher altitudes there's a greater demand for air to supply an engine with oxygen. A turbocharger is the solution.

In the simplest of analogies, think of a turbocharger as two pinwheels connected, back-to-back, via a common shaft. As you blow on one wheel, the other wheel turns too.

Inside a turbocharger, exhaust gases flow out of the combustion chambers into the turbine housing. The exhaust

gas is channeled to the pin wheel, causing the pin wheel "turbine" to rotate.

The turbine wheel turns a common shaft which is connected to a pin wheel on the fresh air side of the turbocharger, known as the "compressor."

The compressor wheel blades draw filtered air into the compressor housing, raising the air's density and pressure, as the air is forced into the engine. More air mixed with more fuel equals more power.

As you add air/fuel to the engine it makes more power. The temperature and flow of the exhaust gas increases. With the increased exhaust flow and temperature, the exhaust pin wheel (turbine) spins faster. Thus, the intake pin wheel (compressor) pressurizes (boosts) more air into the engine. More air/fuel to the engine makes more power, creates additional exhaust flow and temperature... Get the picture?

BOOST DIAGNOSTICS

How can we use the engine's "boost" to diagnose engine performance? There are specifications for boost for the various engines which have been and are in current production. Keep in mind that it takes fuel and air to make power and boost. If the engine meets the boost specification, the power is there and it passes the "Boost Treadmill test."

At this juncture it is tempting to generalize the data. However, I'll avoid the temptation and research the boost specification for a given engine build or, in Cummins-speak, control parts list (CPL). The Cummins CPL is a number that spells out key components (fuel pump settings, turbochargers, cylinder heads, pistons, etc.) used in the engine. The following detailed table presents the data.

Model Year	HP@RPM	Torque @RPM	CPL	Transmission	Comments	Boost Specification
1989-1991	160@2500	400@1600	804	Auto/Manual		22-25
1991.5-1992	160@2500	400@1600	1351	Auto/Manual	Mid-year intercooler	15-19
1992.5-1993	160@2500	400@1600	1579	Auto/Manual	Mid-year change	15-19
1994 12-Valve	160@2500	400@1600	1815	Auto		15-18
	175@2500	420@1600	1816	Manual		15-18
1994.5 12-Valve	160@2500	400@1600	1549	Auto	DOC	15-18
	175@2500	420@1600	1550	Manual	DOC	15-18
1995 12-Valve	160@2500	400@1600	1959	Auto	DOC	15-18
	175@2500	420@1600	1550	Manual	DOC	15-18

DOC = diesel oxidation catalyst NAC = NOx absorption catalyst DPF = diesel particulate filter SCR = selective catalyst reduction (urea)

Model Year	HP@RPM	Torque @RPM	CPL	Transmission	Comments	Boost Specification		
1995.5 12-Valve	160@2500	400@1600	1968	Auto	mid-year change DOC	15-18		
	175@2500	420@1600	1550	Manual	mid-year change DOC	15-18		
1996 12-Valve	180@2500	420@1600	2022	Auto	EPA – DOC	19		
	215@2600	440@1600	2023	Manual	EPA – DOC	25		
	180@2500	420@1600	1863	Auto/Manual	CARB – DOC and EGR	19		
1996.5–1998 12-Valve	180@2500	420@1600	2174	Auto	EPA	19		
	215@2600	440@1600	2175	Manual	EPA	25		
	180@2500	420@1600	2308	Auto/Manual	CARB – DOC and EGR	19		
1998.5 24-Valve	215@2700	420@1600	2098/2513	Auto	EPA	18		
			2280/2515	Auto	CARB	18		
	235@2700	420@1600	2024/2512	Manual	EPA	18		
			2279/2514	Manual	CARB	18		
1999 24-Valve	215@2700	420@1600	2617	Auto	EPA	18		
			2619		CARB	18		
	235@2700	460@1600	2616	Manual	EPA	18		
			2618		CARB	18		
2000 24-Valve	215@2700	420@1600	2660	Auto	EPA	18		
			2661		CARB	18		
	235@2700	460@1600	2662	Manual	EPA	18		
			2663		CARB	18		
2001 24-Valve	235@2700	460@1600	2865/2902	Auto	EPA	19.5		
			2866/2903		CARB	19.5		
			245@2700	505@1600	2496/2904	5 Manual	EPA	19.5
					2497/2905		CARB	19.5
	245@2700	505@1600	2415/2906	6 Manual	EPA	19.5		
			2495/2907		CARB	19.5		
2002 24-Valve	235@2700	460@1600	8030	Auto	EPA	19.5		
			8031		CARB	19.5		
			235@2700	505@1600	8032	5 Manual	EPA	19.5
					8033		CARB	19.5
	235@2700	505@1600	8034	6 Manual	EPA	19.5		
			8035		CARB	19.5		
2003 5.9 HPCR	235@2700	460@1400	8216	47RE Auto	CARB – DOC	23		
			8224	5 Manual	CARB – DOC	23		
	250@2900	460@1400	2624	48RE Auto	EPA – Non-Catalyst	23		
			8223	5 Manual	EPA – Non-Catalyst	23		
	305@2900	555@1400	2998	6 Manual	EPA – Non-Catalyst	26		

DOC = diesel oxidation catalyst NAC = NOx absorption catalyst DPF = diesel particulate filter SCR = selective catalyst reduction (urea)

Model Year	HP@RPM	Torque @RPM	CPL	Transmission	Comments	Boost Specification
2003 5.9 HPCR	235@2700	460@1400	8216	47RE Auto	CARB – DOC	23
			8224	5 Manual	CARB – DOC	23
	250@2900	460@1400	2624	47RE Auto	EPA – Non-Catalyst	23
			8223	5 Manual	EPA – Non-Catalyst	23
	305@2900	555@1400	2998	6 Manual	EPA – Non-Catalyst	26
2003.5 5.9 HPCR	235@2700	460@1400	8410	48RE Auto	CARB – DOC	23
			8412	5 Manual	CARB – DOC	23
	250@2900	460@1400	8212	48RE Auto	EPA – Non-Catalyst	23
			8226	5 Manual	EPA – Non-Catalyst	23
	305@2900	555@1400	8228	6 Manual	EPA – Non-Catalyst	26
			8213	48RE Auto	EPA – Non-Catalyst	26
2004 5.9 HPCR	235@2700	460@1400	8412	48RE Auto	CARB – DOC	23
			8412	6 Manual	CARB – DOC	23
	305@2900	555@1400	8213	48RE Auto	EPA – Non-Catalyst	26
			8228	6 Manual	EPA – Non-Catalyst	26
2004.5 5.9 HPCR	325@2900	600@1600	8350	6 Manual	EPA – DOC	30
			8351	6 Manual	CARB – DOC	30
			8346	48RE Auto	EPA – DOC	30
			8347	48RE Auto	CARB – DOC	30
2005 5.9 HPCR	325@2900	610@1600	8423	6 Manual	EPA – DOC	30
			8424	6 Manual	CARB – DOC	30
			8421	48RE Auto	EPA – DOC	30
			8422	48RE Auto	CARB – DOC	30
2006 5.9 HPCR	325@2900	610@1600	8348	6 Manual	EPA – DOC	30
			8349	6 Manual	CARB – DOC	30
			8344	48RE Auto	EPA – DOC	30
			8345	48RE Auto	CARB – DOC	30
2007 5.9 HPCR	325@2900	610@1600	1091	6 Manual	EPA – DOC	30
			1095	6 Manual	CARB – DOC	30
			1000	48RE Auto	EPA – DOC	30
			1083	48RE Auto	CARB – DOC	30
2007.5 6.7L HPCR Pickup	350@3000	610@1600	8233	6 Manual	EPA – DOC/NAC/DPF	28*
			8234	6 Manual	CARB – DOC/NAC/DPF	28*
		650@1600	8230	68RFE Auto	EPA – DOC/NAC/DPF	28*
			8231	68RFE Auto	CARB – DOC/NAC/DPF	28*
2007.5 6.7L HPCR Cab/Chassis	305@2900	610@1600	8232	6 Manual	EPA – DOC/NAC/DPF	26*
			1264	6 Manual	CARB – DOC/NAC/DPF	26*
			2885	Aisin Auto	EPA – DOC/NAC/DPF	26*
			1257	Aisin Auto	CARB – DOC/NAC/DPF	26*

DOC = diesel oxidation catalyst NAC = NOx absorption catalyst DPF = diesel particulate filter SCR = selective catalyst reduction (urea)

Model Year	HP@RPM	Torque @RPM	CPL	Transmission	Comments	Boost Specification
2008 6.7 Pickup	350@3000	610@1600	1489	6 Manual	All States DOC/NAC/DPF	28*
		650@1600	1490	68RFE Auto	All States DOC/NAC/DPF	28*
2008 Cab/Chassis	305@2900	610@1600	8235	6 Manual	All States DOC/DPF	26*
			2886	Aisin Auto	All States DOC/DPF	26*
2009 6.7 Pickup	350@3000	610@1600	1489	6 Manual	All States DOC/NAC/DPF	28*
			650@1600	1490	68RFE Auto	All States DOC/NAC/DPF
2009 3500 Cab/Chassis	305@2900	610@1600	2780	6 Manual	All States DOC/DPF	26*
			2775	Aisin Auto	All States DOC/DPF	26*
2009 4500-5500 Cab/Chassis	305@2900	610@1600	2779	6 Manual	All States DOC/DPF	26*
			2774	Aisin Auto	All States DOC/DPF	26*
2010 6.7 Pickup	350@3000	610@1600		6 Manual	All States DOC/NAC/DPF	28*
			650@1600		68RFE Auto	All States DOC/NAC/DPF
2010 3500 Cab/Chassis	305@2900	610@1600		6 Manual	All States	26*
				Aisin Auto	All States	26*
2010 4500-5500 Cab/Chassis	305@2900	610@1600		6 Manual	All States	26*
				Aisin Auto	All States	26*
2011 6.7 Pickup	350@3000	610@1400		Manual	All States DOC/NAC/DPF	28*
		650@1600		68RFE Auto	All States DOC/NAC/DPF	28*
2011.5 6.7 Pickup (HO)	350@3000	800@1600		68RFE Auto	All States DOC/NAC/DPF	28*
2011 Cab/Chassis	305@2900	610@1600		Manual	All States SCR System	26*
				Aisin Auto	All States SCR System	26*
2012 6.7 Pickup	350@3000	610@1400		Manual	All States DOC/NAC/DPF	28*
		800@1600		68RFE Auto	All States DOC/NAC/DPF	28*
2012 Cab/Chassis	305@2900	610@1600		Manual	All States SCR System	26*
				Aisin Auto	All States SCR System	26*

DOC = diesel oxidation catalyst NAC = NOx absorption catalyst DPF = diesel particulate filter SCR = selective catalyst reduction (urea)

***The boost numbers for the '07.5 and newer 6.7 liter engine applications are approximate. There can be variance based on the amount of exhaust gas recirculation in the intake air, the intake through the opening and variable geometry turbocharger's position.**

As a side note, did you notice how uncluttered the table was in the early years? Compliance with emissions legislation can make things complicated.

Now that you have the specifications in hand—wait a minute, you don't have a boost gauge? This instrument is easy to source, relatively cheap (\$40-\$60) and easy to install. The majority of gauges on the market are mechanical devices that do not require electricity to operate. To put a gauge in, one can use a "boost bolt" to access the pressurized intake air.

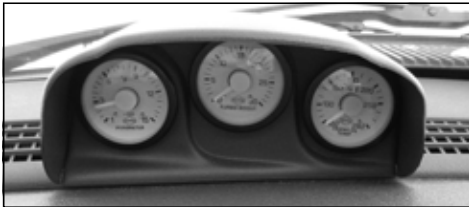

As mentioned, with a gauge installed you can use the boost readings as a diagnostic check of the engine's performance. The engine will need to see a full throttle, loaded condition in order to make its maximum boost number. The easiest way to do this is to drive the truck up a hill. No hills in Kansas? Apply the brakes to load the engine.

How did your truck perform on the boost test we suggested? If your truck didn't seem up-to-par there are several simple checks you can do before you take the truck to a service location. The following are some of the do-it-yourself areas to check:

- Check for quality of fuel.
- Check for full travel of the throttle lever at the fuel pump.
- Check all turbo to intercooler, intercooler to intake manifold hoses and clamps for a tight fit.
- Check the condition of your fuel filter.
- Check for fuel inlet restriction.
- Check the condition of your air filter.
- Check for exhaust leaks prior to turbocharger.
- Check for exhaust system restriction.
- For automatic trucks, check your transmission fluid level.

Hopefully our discussion on boost specifications and the use of turbo boost as a diagnostic tool will help you to ensure the best performance of your truck. Happy motoring.

Robert Patton
TDR Staff

BUYING A USED TRUCK

by Jim Anderson

When you buy a new truck, you are protected by a manufacturer's warranty and the integrity of the dealer from whom you purchase. When buying a used vehicle, you are much less protected by the law and frequently will have no warranty from a manufacturer to fall back on in case of a problem. Therefore you must be much more careful in inspecting your intended purchase. The benefits to the used truck purchase: the vehicle cost is less than new, used trucks typically have had the "new vehicle" bugs fixed, and they represent greater value for the dollar since the initial depreciation has already been taken by the first owner.

A whole market has sprung up in the last few years for used Dodge/Cummins Turbo Diesel trucks, fueled in part by the high cost of a new one, and by the fact that even trucks with high mileage have lots of life left in them due to the legendary reliability and durability of the Cummins diesel.

This has had a side benefit in that used Dodge/Cummins trucks have retained a greater percentage of their resale value than the average for all diesel trucks, and they command high prices on used vehicle lots. This means you may pay more for your truck but will get more for it when you eventually become a seller. A well maintained truck with high mileage should not be disregarded as a good value, since with good regular maintenance these trucks can reliably run half a million miles and more!

Vehicle purchasing can be divided into two parts. One is buying the metal, and the other is buying the money used for the purchase. Your goal as a used truck purchaser is to get both parts right.

How do you select just the right truck, and how do you make sure it has been well maintained? You surely don't want to buy a "lemon" when an engine can cost upwards of \$7,000, a new transmission can cost upwards of \$3,500, and a P-7100 rebuilt injection pump can cost you \$1,400. Here are some buying tips to help you find just the right one for you!

Keep in mind that this is likely the second largest purchase you'll ever make, second only to a home. Some folks spend more on their transportation in their lifetime than they spend on housing. While you may live in one place your entire life, the average owner trades vehicles once every five years. Every dollar saved on the purchase price of either a home or a vehicle will also save on interest dollars paid back if you are getting a loan. So a dollar saved may actually amount to as much as \$1.25 over the life of the loan.

Inform Yourself

Before you ever set foot on a dealer lot or peruse the want ads, take the time to familiarize yourself with the various models and options offered by the manufacturer, and see how they match your intended use. Narrow your search down to those models and model years which fit your budget and which will do the intended job. Select only those models with the options you want. Make a list of specifications, keep it with you during your search, and keep to your list.

For example, if you determine you want a truck for hauling and towing, but want an Extended Cab model with SLT interior, do the research to find which models and options are required to tow the intended weight, then stick to inspecting trucks which meet those criteria. Your familiarization session will lead you to ask the right questions when you visit the dealer lot or make contact with private sellers.

Next, check the used vehicle value guides. Most banks and other agencies that make car loans will have a variety of used vehicle value guides such as the Kelly Blue Book or NADA book that list wholesale, retail, and loan values for each model, each accessory, and offer mileage compensation factors. These books are filled with option facts and regional pricing, so can serve as a useful guide to true worth. For those with a computer, walk your fingers across a computer keyboard and visit the various web sites that offer needed information. These include Kelly Blue Book (kbb.com), NADA used truck guide (NADA.com), carprice.com, edmunds.com, and others. The dot com sites often track actual prices paid for trucks in your area or in a nearby metropolitan area.

If you want to research a particular truck, web sites exist that allow you to check a particular serial numbered truck for lost, stolen, totaled, reconstructed, etc, titles (carfax.com) for a nominal fee. You can also determine if a vehicle has been included in federal safety recalls by visiting several other sites. Mining information from the web can be rewarding, though time consuming, but the more thorough your research at this stage, the more informed you will become as a buyer.

Now is also the time to make a call to your automobile insurance agent for a rate quote to make sure there are no after-the-purchase unpleasant surprises in this part of truck ownership.

If you plan to get a loan for the vehicle, now is also a good time to shop around for the best interest rate and payment plans, and to get approval for the loan. It is as important to shop for the cost of money as it is to negotiate a good price for the truck. After you have done your research, then it is finally time to go looking for just the right truck! You now have a pretty good idea of what you want, what you might have to pay, and how you're going to pay for it.

My advice is to buy the latest model truck with the lowest mileage that you can afford. The newer the truck, the lower the maintenance and repair costs are likely to be over time. Look for a well-maintained "cream puff." They're out there, but it is up to you to find them.

Inspection Time

In looking at a used vehicle, don't be dazzled by surface shine. Look behind the shine to uncover a vehicle's true condition. Look at the truck's overall cleanliness. There is a difference in appearance between a good cleanup job and continuous regular cleaning over the truck's life to the

present. Look at the interior for worn carpets and upholstery. (The editor's favorite place to check for attention to detail cleanliness—the door jambs. A clean door jamb typically indicates a vehicle that has been fanatically maintained.) Wear should be commensurate with mileage. Look underneath the body for caked mud and dirt. This indicates off-road operation or an unintentional trip into the ditch. Look under the hood. Lots of dirt can indicate severe use and little maintenance.

Check for worn or chafed hoses, oil leaks, coolant leaks, etc. Pull the dipsticks and check fluid colors and condition.

Sight down the body sides to see if the panels are smooth. If they're wavy, the truck has been wrecked, and further inspection underneath will reveal the severity of the accident. Paint color differences between panels and or variations in body seam gaps also indicate a wreck in the truck's past.

Inspect tires for uneven wear to determine if there are suspension or axle problems. This can also be an indicator of improperly repaired wreck damage.

Look for lube drips from the underside of the engine, transmission and axles. Seal repairs may have to be made. A light oil drip or evidence of misting near the engine road draft tube is normal. Look in the glove box and console to see if any maintenance receipts or records have been left behind and compare them with what you see. Go for a ride and note if the engine idles smoothly and pulls strongly. Do the transmission and clutch work as intended? Does the automatic transmission shift without slipping or "hanging between gears"? Do the brakes pull to one side? Does the truck steer correctly?

While driving, note if there is excessive smoke from the exhaust. Black smoke indicates overfueling or a clogged air filter. White or gray smoke indicates excessive oil getting by the piston rings or an injection pump problem. A puff of smoke of any color at startup is normal, but should abate when the engine warms.

Walk around the truck immediately after the ride and note any smells of hot dragging brakes or leaking fuel. A hot oil smell can indicate an oil leak onto the exhaust system.

Don't be embarrassed to ask to put the truck up on a lift for a more thorough inspection, or to take the truck to a trusted mechanic for a professional inspection. A professional independent inspection for a fee is cheap insurance that you are making a wise purchase decision. After you are fully satisfied that the truck is what it is represented to be, move on to the next step.

Contact the Owner

There are many possible reasons why this particular truck came to be for sale, and it is up to you to determine the true reason. Is the owner financially able to afford a new vehicle with more fancy gadgets, or was the owner tired of fixing a problem or problems repeatedly? Is the owner simply selling a vehicle that is no longer needed? It is up to you to find out.

When you find a likely candidate and your search narrows to a specific vehicle you may want to buy, consult your list again to make sure it meets all criteria. First on your "to do" list following a second general walk-around inspection and a ride-and-drive session of a particular truck should be some research to find out who the former owner was and initiate a conversation.

If you're buying from a dealer, ask the owner what the mileage was at turn in time and on what date the vehicle was turned in. If the truck has been in a dealer's possession for a while, has it been used for hauling chores with no maintenance? Have other potential buyers shied away from it for some reason not readily evident? Find out why. Ask the former owner what maintenance has been performed and when, and if the truck has been wrecked. What was it used for? Was it satisfactory for that use? If the owner has maintenance records, arrange to pick them up if you buy the truck.

Finishing Up

You've done the research, negotiated the price, and now it is time to exchange dollars for the vehicle. The job's not done until the paperwork is finished—and the paperwork had better be right! If buying from a dealer, you should receive a bill of sale and certification of the odometer reading, along with several other pieces of paper, which will vary by state. Usually the dealer will apply for a new title in your name. If buying from a private individual, you should receive a clear title signed over to you by the owner. You will then take the title to your vehicle registration place to get a new title in your name.

Either a bill of sale from a dealer or a signed title from the owner should be placed in your hands at the time you give them your check—no exceptions, and no excuses by the seller. Remember, the job's not done until the paperwork is right!

Make sure the serial number on all paperwork agrees with the serial number stamped into the left front corner of the dashboard. Paperwork mistakes in this area are frequent and hard to correct later.

Before driving your new purchase home, call your insurance agent to insurance. Failure to do so could have disastrous consequences just down the road.

Finally, if there is any remaining warranty on the vehicle, be sure to fill out and send in the paperwork to get it transferred to you. If the truck is less than five years old and has less than 100,000 miles on the odometer, you should transfer the remaining engine warranty. That's it. You now own your new (to you) truck, and if you have researched fully and purchased carefully, you'll have many miles of enjoyable cruisin' ahead of you.

Jim Anderson
TDR Writer

WHAT DOES EVERY TURBO DIESEL OWNER NEED TO KNOW?

by Robert Patton

I am reminded daily that “the world is going digital.” Perhaps so, but as the last of an older breed I enjoy sitting in the EZ chair and reading the newspaper and periodical magazines.

Always on the lookout for interesting ideas that serve as an inspiration to write, I noted an article in the American Motorcycle Association’s American Motorcyclist titled, “What Does Every Motorcyclist Need to Know?”

Shazam! Change the title to “What Does Every Turbo Diesel Owner Need to Know?” and I’ve got the basis for a good article. So, here goes...

TDR Related Items

First things first—you’ve got the magazine in hand and I thank you for your subscription. Now that I have paid due tribute, this resource article is going to direct you to the TDR’s web site (www.tdr1.com) because I’m guessing that you may not be aware of the wealth of information that is available to you.

Once at the TDR’s main page, look to the left and notice the heading “MAGAZINE.” Scroll down to “Technical FAQs” and print the file. Read the FAQs and you’ll be on your way to shedding the title of “diesel newbie.”

Do you want to impress your neighbor with your knowledge of year-by-year, model-by-model changes to the truck? Or, do you have a specific question about gear ratios or horsepower and torque ratings for a given year? Tab down to “Buyer’s Guide” and the 150+ page (we’re continuously adding to the Buyer’s Guide) PDF file is available for you to download. This book is a real gem.

With an eye on the basics one has to realize that your truck’s Owner’s Manual holds a wealth of information. From remote key lock reprogramming (some models), to tire inflation pressures, to the fluid capacities... the standing joke among TDR staff members is that there would not be a need for the TDR if owners would consult their Owner’s Manual.

Kidding aside, the Owner’s Manual is an excellent resource book and it covers the lubricants and fluids needed in your truck. The catch: often the Owner’s Manual only gives the Chrysler/Mopar specification or part number for a fluid. Should you want to source a generic fluid (read: less expensive), you will again find the TDR’s Turbo Diesel Buyer’s Guide to be a great resource. A quick thumb to the index shows the title “Liquids in Your Truck” and this article is helpful in your search for lower cost consumable items.

Lower cost is always an important matter. Go back to the Buyer’s Guide index and note the title “Part Number Reference.” This chart gives oil, fuel and air filter crossover numbers; belt and hose numbers; and other miscellaneous parts. Use the chart wisely and save some additional money.

If I’ve not yet convinced you that the TDR Buyer’s Guide is an excellent resource, there is another chapter that is worthwhile to those looking for performance specifications. Take a look at “Your Truck and the Boost Treadmill” and you’ll see what I mean. Other noteworthy chapters: Most Common Problems, Preventive Maintenance, Mechanics Tips, and Memorable TDR Articles.

Have you encountered a problem with your truck that you think may have been previously discussed? While you’re at the TDR’s web site, tab down to “Magazine Index” and you’ll be able to print files and then search for the TDR magazine’s chapter-and-verse coverage of a problem, a gadget or a gizmo. My thanks to Bob and Jeannette Vallier for providing this valuable resource for us.

Still plagued with a problem or have an unanswered question? If you’ve not yet activated your username and password at the TDR’s web site, now is an excellent time to do so. Log on to the members’ “Discussion Forums” and ask the helpful TDR membership.

Enough about the technical information found at the TDR’s web site; what else does every Turbo Diesel owner need to know? For an in-depth look at the truck there is nothing better than a factory service manual. Back in the early 90s the book was one volume and maybe 500 pages. The latest service manual is not even offered in print, it is a \$120 CD. The last print versions were 10 volumes and \$450. An alternate source is the Haynes manuals at about 350 pages for \$18. Both the factory manuals and Haynes books can be found at Geno’s Garage (800) 755-1715 or www.genosgarage.com.

Factory Technical Service Bulletins (TSBs)

For a quick look at TSBs you can look at page 54 of this magazine or go to the TDR’s web site and tab down to “Dodge Technical Service Bulletins” and take a look through the archives. Alternately the 150+ page pdf file “Turbo Diesel Buyer’s Guide” (that you previously printed?) has the same TSB summary.

Chrysler's TechAuthority – An Outstanding Resource

The TDR's list of technical service bulletins is provided as a service to the membership. We recognize and observe copyright, and our listing is only a summary of the TSB. If you need the entire text you can visit your dealer and discuss the referenced TSB number. Alternately, you can log onto Chrysler's TechAuthority website (www.techauthority.com) and you can purchase *all* of the TSBs that may apply to your truck based on your truck's vehicle identification number (VIN). This service is \$20 and the information is invaluable.

More about TechAuthority: I spent several days putting together the TSB summary for this year. While I was at the TechAuthority web site using the VIN for my '07.5 Turbo diesel truck, I noted the tab "Service Info." I clicked onto it and I was amazed at the wealth of information that was available.

I could look up front end alignment specifications. I could review the flywheel runout specifications. I looked up the removal of upper and lower control arms. I looked up the removal of the drive shaft center bearing. I looked up the troublesome diagnostic trouble code (DTC) P0106 that randomly occurs on my truck.

Then it hit me: it appears that the entire service manual for my truck was/is available for my viewing for the \$20 daily fee. To confirm my assumption I called Tech Authority and verified that the information that I was viewing was, in fact, from the factory service manual.

More accolades for TechAuthority: I mentioned the P0106 code that randomly occurs on my '07.5 truck. I was armed with several VINs, so I did some research to see how a '07 truck with the 5.9-liter engine might differ from my '07.5 truck with the 6.7-liter engine. I started with a search on my truck with the 6.7. Using "Service Info," I scrolled down to item "28 DTC Based Diagnostics," then scrolled down to "MODULE, Engine Control (ECM) 6.7L."

Next: Diagnostics and Testing

Next: P0106

I was amazed at the information on code P0106. There was a Theory of Operation; When Monitored; Possible Causes; and a Service Tree.

I did the same for the '07 truck with the 5.9-liter engine and there was much less information. So, for owners of the '07.5 and newer trucks with 6.7-liter engines, there is a world of information that awaits at the TechAuthority web site.

A side note to the 6.7-liter audience: As I reviewed the "Theory of Operation" for my P0106, the write up motivated me to look at other codes with a focus on whether the code has a derate-effect on the engine. For example, I found these two derate codes:

P0217 – Coolant Temperature Too High results in, "during this time the customer may experience an engine power derate."

P242F – Diesel Particulate Filter Restriction – Ash Accumulation results in, "If the vehicle's EVIC message center notification is ignored, the engine will eventually derate and set a DTC and MIL lamp."

I searched for others, but these were the only two that I came across in my quick review. Elsewhere in this magazine (page 91, "Make It Go Away") you can read further my frustration with DTC codes and engine derate or damage implications.

The Boy Scouts

Other things you need to know? Were you a Boy Scout? It is always a good idea to be prepared. A "boonie box" of spare parts to carry around under the seat is a good idea. My spares: a fuel filter, belt, belt tensioner, hoses, thermostat and a small tool kit. By the way, a spare key hidden underneath the truck has saved me from inconvenience many times.

Summary

My review of the magazine, the TDR's web site and the TDR Turbo Diesel Buyer's Guide has convinced me that this membership group is your best resource. My sincere thanks to all of the members that have helped answer what every owner needs to know on the TDR's active web site message boards. Also, Chrysler's TechAuthority is an excellent web site location for information. And now, I'm at a loss for further recommendations. So, thumb-through the magazine to see what other TDR writers had to say about what every owner needs to know.

Robert Patton
TDR Staff

THE DRIVING FORCE BEHIND THE CHANGES TO THE CUMMINS ENGINE/ MEANINGFUL ABBREVIATIONS

by Robert Patton

EPA, NO_x, PM, SCR, EGR, DPF, NAC, VGT, ULSD, HPCR, HCCI, NMHC, ACERT, TITT: Can you pick the abbreviation that is non-diesel, non-emissions related? It's easy, TITT as in "throw in the towel." The balance of the abbreviations serves to bewilder your diligent scribe. However, with a new round of diesel exhaust emission legislation less than two years away and with ultra low sulfur diesel fuel (abbreviation: ULSD), due in the summer of '06, it is appropriate that we understand what the abbreviations will mean to the diesel enthusiast.

As TDR subscribers know, emission legislation dates are the driving force in the changes to the Cummins engine hardware. To make a boring story into a relevant topic, the subject matter has to address "what does it mean to me?" The best way to answer this question is to crank-up the way-back machine to Issue 40 and look at the progression of the ever-tightening emissions standards.

After we review the material which answers the question, "what does it mean to me?" material, I'll attempt to tie the big picture together with a look at those annoying abbreviations and what is on the horizon for 2006 and 2007.

Boring Stuff?

While it might be tempting to skip through this subtitle, I'll ask for your concentrated efforts as we simplify (oversimplify?) the two emissions components that concern the diesel engineer: oxides of nitrogen (NO_x) and particulate matter (PM). The following paragraphs may provide us a more informed understanding of these two emissions components.

Oxides of Nitrogen (NO_x)

- One of the primary regulated pollutants from diesel engines.
- Reacts with hydrocarbons in the presence of sunlight to form ozone.
- Formed by reaction between nitrogen and oxygen in the combustion chamber.
- NO_x formation increases with higher combustion temperature and cylinder pressures.
- Methods of reduction include lower intake manifold temperature, lower in-cylinder temperature, retarded fuel injection and combustion optimization. Any in-cylinder approach to NO_x reduction involves lowering the temperature and limiting the time of the combustion event.
- Potential impacts can be higher fuel consumption and requirement of a more complex cooling system.

Note the sharp, ten-fold drop in emissions from year 2004 to 2007. I recall that one of the first TDR magazines stated that emissions were the driving force behind changes to the diesel engine. The 2007 emissions targets nail home that statement. Certainly ultra-low sulfur fuel will help, but the engineering it will take to meet the targets is difficult to imagine.

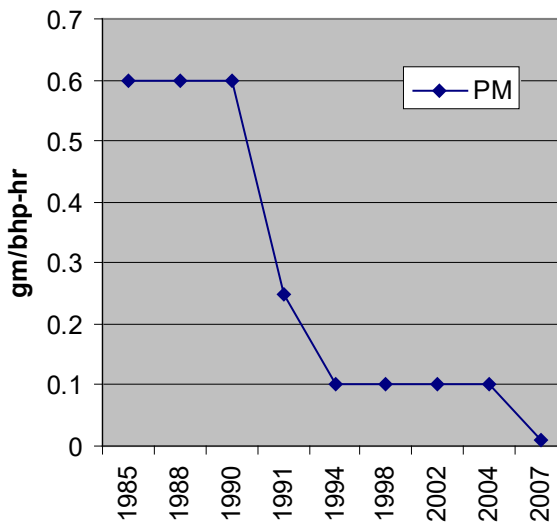
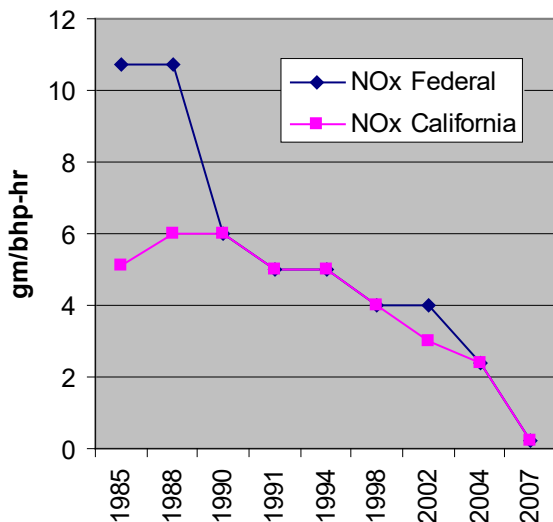

Particulate Matter (PM)

- Often visible as black smoke.
- Formed when insufficient air or low combustion temperature prohibits complete combustion of the free carbon.
- Primarily partially burned fuel and lube oil.
- Methods of control include oil consumption reduction, catalytic converters, combustion system development and higher fuel injection pressures.

To oversimplify, think back to last winter and the many fireside evenings you enjoyed. As you built the fire, there was inefficient combustion, characterized by black smoke and not much heat generation. Thirty minutes into the exercise you were sitting back in the easy chair, with a raging fire, no more black smoke, a beautiful yellow and blue flame, and lots of heat.

Now, refer back to the NO_x and PM bullet statements and reflect on the following: the design engineers could control particulates (PM) by raising the combustion efficiency (temperatures and pressures). But, raising temperatures and pressures causes the formation of oxides of nitrogen (NO_x) to go out of the emissions box. Likewise, efficiency and heat of combustion can be sacrificed to meet the NO_x legislation, but the particulates go out of the emissions box. How does the engineer get the teeter-totter level?

As an interesting sidenote, NO_x not only is formed in internal combustion engines, it is the result of elevating the temperature of air—made up of 79% Nitrogen and 21% Oxygen—high enough for the reaction to occur. One of the most significant sources of NO_x formation in nature is lightning.

The reaction that forms NO_x is also time related; the longer the temperature remains elevated, the greater the level of NO_x formation.

In the diesel engine, NO_x formation can be correlated to engine performance; the higher the rate of formation, the more efficient the engine. As most are aware, the impact of reducing NO_x emissions is increased fuel consumption, which is the result of reduced efficiency.

For a good demonstration of the principle, consider that in-cylinder temperatures are much higher on two-stroke engines because fuel is provided on every stroke. Also, consider the lack of oil control that contributes to too many particulate emissions. These factors made it impossible for two-stroke engines to meet emission targets and maintain fuel consumption and other performance targets. The 1988 on-highway emissions regulations were the final blow to the two-stroke diesel in trucking applications. Two-stroke diesels are now only produced for off-highway and generator set markets.

The method of attack in reducing NO_x formation in the diesel engine is basically twofold: a) reduce the in-cylinder temperature and/or, b) reduce the time for the reaction to occur. Control of the temperature within the cylinder is

managed in part by reduced intake manifold temperature (an intercooler/charge air cooler). Although not used on our Cummins diesel engines, exhaust gas recirculation (EGR) is another method used to control the in-cylinder temperature and, in turn, NO_x formation. Recirculated exhaust gas is oxygen-depleted and the inert gas acts to buffer the combustion event thus lowering the in-cylinder temperature. Reduced reaction time is controlled largely by retardation of the injector timing. Also note the '03-'05 Turbo Diesel engine with its high-pressure, common-rail (HPCR) fuel injection system gives a pilot shot of fuel prior to, and post of the larger injection event. The pilot shots of fuel help control the temperature and reduce NO_x formation. Pilot injection also has greatly reduced the noise level that is associated with diesel combustion.

As you review the NO_x and PM bullets, you can understand the balancing act the engineer has to perform. Now, add to the emissions teeter-totter the need for the engineer to deliver to the market place an engine that can maintain or show an increase in fuel economy. Further, competition dictates higher performance from the engine. Quite a job for the engineering community.

THE LOOK AHEAD

Back to the Basics

For easy understanding and efficient recall, let's start with a glossary of terms that will be used in this article.

EPA: Environmental Protection Agency, the governmental department that is responsible for governing diesel exhaust emissions.

NO_x: oxides of nitrogen, a key pollutant that reacts with hydrocarbons in the presence of sunlight to form ozone.

PM: particulate matter, another key diesel pollutant that is primarily soot and other combustion byproducts that form urban smog.

SCR: selective catalytic reduction, an aftertreatment technology that uses a chemical reductant (urea) that is injected into the exhaust stream where it transforms into ammonia and reacts with NO_x on a catalyst, converting the NO_x to nitrogen and water vapor.

EGR: exhaust gas recirculation, a technology that diverts a small percentage of the oxygen depleted, inert exhaust gas back into the cylinder to help lower the combustion temperatures, thus reducing NO_x.

DPF: diesel particulate filter, also known as a particulate trap. DPFs will be used to capture particles of soot in a semi-porous medium as they flow through the exhaust system. DPFs are available in passive or active configurations. Active DPFs use a control system to actively promote regeneration events.

NAC: NO_x absorber catalyst, a catalyst that releases NO_x for a conversion to nitrogen gas and water vapor.

VGT: variable geometry turbo, turbochargers that constantly adjust the amount of airflow into the combustion chamber, optimizing performance and efficiency. In essence, the turbine casing varies from a small to a large cross section.

ULSD: ultra low sulfur diesel, this fuel is scheduled to be available in September 2006. Over the years the sulfur in diesel fuel has all but been removed. The standards: prior to 1994 – 5000 ppm; 1994 – 500 ppm; 2006 – 15 ppm. It is interesting to note that the European standard is 50 ppm which was enacted in 2004. With ULSD in September 2006 the United States will have the world's strictest standard.

HPCR: high-pressure, common-rail, this is the type of fuel system that is currently produced for our Dodge/Cummins pickup trucks.

HCCI: homogeneous charge compression ignition, a method of in-cylinder NO_x reduction. Think of HCCI as "massive EGR."

NMHC: non-methane hydrocarbons, these are primarily unburned fuel in the exhaust stream and are not a substantial part of the diesel emissions problem. In 2002 the EPA added the NMHC number to the NO_x number for a total standard of 2.5-g/bhp-hr (NO_x + NMHC).

ACERT: advanced combustion emission reduction technology, the abbreviation for Caterpillar's emission control system.

The 2007 EPA Emissions Rules

Looking ahead to 2007-2010, the emissions requirements will change dramatically for diesel pickup trucks. Both NO_x and PM are reduced by 90% from 2004 levels. Specifically, NO_x must be reduced to 0.2 grams/brake horsepower-hour by 2010, while the particulate standard is reduced to 0.01 g/bhp-hr PM beginning in 2007.

The EPA has allowed for NO_x phase-in from 2007 through 2009. During this time, 50% of the engines produced must meet the 0.2 g/bhp-hr NO_x standard, while 50% may continue to meet the current 2.5 g/bhp-hr NO_x + NMHC standard.

Most engine manufacturers will use the NO_x phase-in provisions along with averaging to certify engines to a NO_x value roughly halfway between the 2004 number and the final 2010 NO_x level. This calculates to approximately 1.2 g/bhp-hr NO_x.

The PM level is not phased in, and thus all engine production is required to be at 0.01 g/bhp-hr PM beginning January 2007.

In addition to the lower NO_x and PM levels, crankcase gases will be included in the emissions measurements. This requirement will drive closed crankcase systems for 2007 or ultra-low emissions from open systems. Open systems allow crankcase gases to be vented into the atmosphere through a breather tube. Closed systems reroute crankcase

ventilation gases from the breather tube back into the engine intake airflow to be used for combustion.

Likely there will be further EPA regulations which will require advanced onboard diagnostics, which will lead to additional sensors to monitor the effectiveness of emissions systems on the engine.

Ultra-Low Sulfur Fuel

In addition to new exhaust emissions standards and in support of the new exhaust emissions, the EPA is lowering the limit for diesel fuel sulfur from 500 parts per million (ppm) to 15 ppm. The new fuel standard will be phased in beginning September 1, 2006 (80% participation) through September 1, 2010 (100% participation). It is expected that 15-ppm fuel will be widely available. On a volume basis, over 95% of highway diesel fuel produced in 2006 is projected to meet the 15-ppm sulfur standard. On a facility basis, over 90% of refineries and importers have stated that they plan to produce some 15-ppm diesel fuel. It is projected that the additional cost of the new fuel will be less than 5¢/gallon.

Ultra-low sulfur fuel (ULSD) has several beneficial effects. It inherently produces less PM from combustion, so it is a PM control strategy for all in-use equipment. And, just like unleaded gasoline in the early '70s, ULSD enables NO_x absorber catalyst (NAC) technology to be highly effective and reduces the production of sulfuric acid.

In 1994 there were widespread problems associated with the introduction of low sulfur diesel. The desulphurization process that removes the sulfur plays havoc with the aromatic composition of the fuel. The change in composition caused shrinking, cracking and oxidation of rubber compounds, specifically fuel pump o-rings, and fuel leakage was the result. Manufacturers scrambled to switch the composition of their fuel pump seals.

Many tried to link the fuel pump leakage problem to the lower lubricity of '94s low sulfur fuel. However, a fuel lubricity specification was never adopted by the American Society of Testing and Materials (ASTM). For 2007 the ASTM has set fuel lubricity standards and these are set to take effect in early 2006.

Cooled EGR to Reduce NOx

Cooled EGR is an effective NO_x control. The EGR system takes a measured quantity of exhaust gas, passes it through a cooler before mixing it with the incoming air charge to the cylinder. The EGR adds heat capacity and reduces oxygen concentration in the combustion chamber by diluting the incoming ambient air. During combustion, EGR has the effect of reducing flame temperatures, which in turn reduces NO_x production since NO_x is proportional to flame temperature.

In order to control both NO_x and particulate emissions accurately, the amount of recirculated exhaust gas and air has to be precisely metered into the engine under all operating conditions. This has driven the use of advanced

variable geometry turbochargers (VGT) that continuously vary the quantity of air delivered to the engine.

Aftertreatment Solutions to Reduce NO_x

While cooled EGR is an in-cylinder technology that can reduce NO_x, there are several aftertreatment solutions which can achieve reduced NO_x levels by treating the exhaust gases after they leave the engine. These include selective catalytic reduction (SCR), NO_x adsorbers and lean-NO_x catalysts.

SCR systems use a chemical reductant, in this case urea, which converts to ammonia in the exhaust stream and reacts with NO_x over a catalyst to form harmless nitrogen gas and water. Urea is a benign substance that is generally made from natural gas and widely used in industry and agriculture.

The SCR-urea catalyst is a more mature technology. The first SCR applications have been implemented in Europe and Japan. And, while the EPA has not said no to SCR, the world's diesel manufacturers have an understanding of the problems associated with SCR in the US—specifically distribution at fueling locations, additional tanks and plumbing on trucks and controls to ensure the operator refills the SCR tanks. Nevertheless, the European diesel manufacturers as well as Detroit Diesel are intent on using SCR technology for the North American market in 2007.

For several reasons Cummins has chosen SCR for its engine in Europe: the NO_x limits in Europe are a bit more lenient; relative to the cost of diesel fuel, the urea price is low; and there is a supporting urea distribution infrastructure.

For the North American market Cummins will continue with cooled EGR and work with original equipment manufacturers to select the appropriate NO_x aftertreatment.

Caterpillar will continue with their ACERT combustion technology and the appropriate NO_x aftertreatment. In a November '04 issue of [Transportation Topics](#), William Morris, chief engineer for on-highway engines at Caterpillar responded, "the selective catalytic reduction process 'was at the bottom of the list for 2010 solutions.' Morris said Caterpillar was more interested in modifying its existing emission control system called ACERT and that Caterpillar was doing something similar in 2007 with new designs for 'pistons, rings and liners' to improve the combustion that takes place in the cylinder."

NO_x Adsorber Catalyst to Reduce NO_x

The NO_x adsorber catalyst (NAC) is a technology developed in the late 1990s. The NAC uses a combination of base metal oxide and precious metal coatings to effect control of NO_x. The base metal component (for example, barium oxide) reacts with NO_x to form barium nitrate—effectively storing the NO_x on the surface of the catalyst. When the available storage sites are occupied, the catalyst is operated briefly under rich exhaust gas conditions (the air-to-fuel ratio is adjusted to eliminate oxygen in the exhaust). This releases the NO_x and allows it to be converted to nitrogen

gas and water vapor. Just like unleaded fuel in the early 70s, ULSD enables NAC technology to be implemented.

The elimination of all excess oxygen in the exhaust gas for a short period of time can be accomplished by operating the engine in a rich mode. This is done by injecting fuel directly into the exhaust stream ahead of the adsorber to consume the remaining oxygen in the exhaust. Either way, the engine and catalyst must be controlled as a system to determine exactly when regeneration is needed, and to control the exhaust parameters during regeneration itself.

NO_x adsorbers are expected to appear first in light-duty applications.

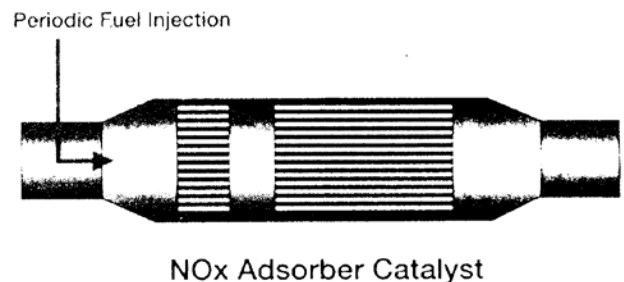

Selective Catalytic Reduction - SCR

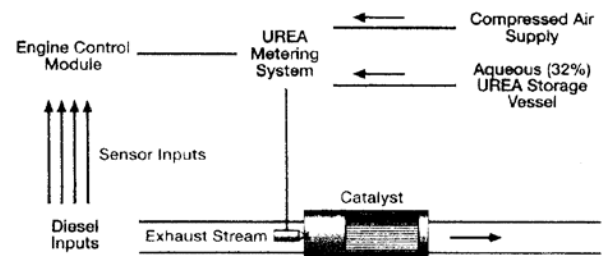

Basic Principal - Spraying UREA into the exhaust stream to promote NO_x reducing catalyst activity.

PM Reduction

Previous reductions in particulate matter emissions have been achieved through engine combustion improvements and oxidation catalysts, the stringent 2007 particulate standards (90% lower than current-day standards) will require very effective particulate aftertreatment.

The active diesel particulate filter (DPF) is the only current technical option for meeting the 2007 PM emissions standards. It is expected that all engine manufacturers will use this technology.

Filtration of exhaust gas to remove soot particles is accomplished using porous ceramic media generally made of cordierite or silicon carbide. A typical filter consists of an array of small channels that the exhaust gas flows through. Adjacent channels are plugged at opposite ends, forcing the exhaust gas to flow through the porous wall, capturing the soot particles on the surface and inside pores of the media. Soot accumulates in the filter, and when sufficient heat is present a regeneration event occurs, oxidizing the soot and

cleaning the filter.

There are several methods to control or raise the exhaust temperature to manage the regeneration event in the DPF. The most promising methods for an active integrated system for 2007 are management of the engine combustion process in combination with an additional oxidation catalyst. This will allow regeneration to take place under low-ambient/low-load conditions when exhaust temperatures are low, as well as during normal operation.

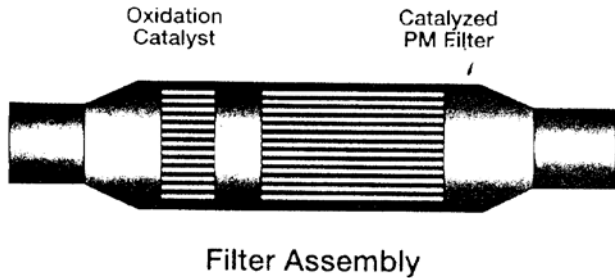

As oil is consumed and particulate matter is burned off through regeneration they become ash and collect in the filter. The ash must be cleaned from the filter or plugging will occur. Maintenance may be required on diesel particulate filters.

Cummins is currently working with oil manufacturers on the development of low-ash oils and to determine how different oil additive components may behave with regard to filter plugging. If maintenance of the diesel particulate filter is required, it is anticipated that it will be at relatively high-mileage intervals of 185,000-250,000 miles.

2007 Lubricating Oil

New specifications are being developed for lubrication oil compatible with the low-emissions engines for 2007-2010. The primary focus will be to make the oils compatible with aftertreatment devices. For 2007, the immediate requirement is to reduce ash in order to enable extended maintenance intervals on the diesel particulate filter while maintaining the important lubricity capability of the lubricant.

And the Bottom Line?

Yours truly is not an accomplished prognosticator. I am often reminded that we incorrectly predicted that the post 1/1/04 Turbo Diesel would have EGR. While the Ford and General Motors diesels were saddled with EDR, the engineers at Cummins were diligent with their in-cylinder development and avoided adding the recirculated exhaust gas plumbing and controls to the engine.

With my qualifications duly noted, as we look toward the future I will stick with factual data and quotations from other periodicals.

- ULSD is currently legislated to be available in September

of '06. The problems associated with the introduction of low sulfur diesel fuel in 1994 have not been forgotten and the fuel vendors and the ASTM have standards in place to avert problems.

- Particulate control: according to Diesel Progress, November 2004: "Major manufacturers such as Caterpillar, Cummins, Detroit Diesel and International Truck and Engine have adopted diesel particulate filters as the preferred strategy/technology for PM reduction, but there is no consensus on NO_x control technologies. The two most practical and cost-effective approaches to lower NO_x emissions from diesel trucks are in-cylinder techniques such as a high rate of EGR and exhaust system technologies such as urea-SCR, which is being adopted in the European Union starting in 2005."

- Further, Diesel Progress, December 2004 notes: "Diesel particulate filter can be considered a relatively mature technology. At least in light-duty vehicles, DPFs have been used in high-volume applications in diesel passenger cars in Europe, with over 850,000 systems sold since 2000. In the US, several heavy-duty engine manufacturers have been testing their 2007 truck prototypes and expressed confidence in the DPF technology."

- Confident that PM can be addressed with DPFs? Let's continue to address NO_x. Consider this excerpt from Successful Dealer, March 2004: "According to technology chief John Wall, Cummins already has laboratory engines that can achieve a 1g level for NO_x emissions and he is confident of being able to manufacture production engines that will meet the 1.2g "averaging" level without exhaust aftertreatment."

"Furthermore, Wall said highly-advanced combustion research techniques that actually use windows on the combustion process, and the complex modeling they can now do, allow him to predict that fuel consumption will not take a hit next time. It may even improve in some applications. Conclusion: For Cummins the refinement of the EGR process currently in place is the right emissions strategy for North America.

"In Europe, Wall says it is likely Cummins will use the alternative selective catalytic-reduction (SCR) technology. The requirements for Euro 5 are less stringent on PM and the big differential between the cost of fuel between European countries and the United States (their cost per gallon is four or five times ours) means SCR is the more economical solution.

"The economics are simply not there for the US. However, he did not rule out some SCR for 2010 to clean up the NO_x from 1.2g down to the 0.2g levels."

- Specifically, how about NO_x control on our light-duty pickup diesel. Scouring through the trade publication Transportation Topics—Equipment and Maintenance Update, March 2004, I found another interview with Cummins' John Wall. "John Wall, vice president and chief technical officer for engine manufacturer Cummins, said

NAC adsorbers would likely go into lighter applications first because ‘they have a lot of precious metals in them and they get more expensive as you scale them up to heavy-duty applications.’”

To conclude: your light-duty Cummins engine will require some form of exhaust aftertreatment. The allowable NO_x phase-in between years ‘07 to ‘10 make prediction difficult and complex. Therefore I will refrain from bold statements laden with abbreviations like, “expect an EGR and VGT-equipped engine with a DPF and later a NAC.

Time will tell. I will keep a watchful eye toward press information and an open ear when in conversation with others.

The Right Technology

As a postscript to our crystal ball look into the future I found an article in the 1/3/05 Transportation Topics magazine that give further insight into the use of SCR to control NO_x emissions. As was mentioned several times in the article, the EPA would not take a stand on the technology the manufacturers should use. However, there was pressure against the SCR concept. How so? Consider the following from TT: “SCR can reduce levels of NO_x by mixing urea, an ammonia-based solution, into the exhaust stream ahead of the catalytic converter. SCR would allow the combustion process to operate in a more traditional way, proponents have argued.

“Detroit Diesel Corporation, a subsidiary of Freightliner, plus the powertrain units of Mack Trucks and Volvo Trucks North America had been considering SCR for 2007 engines.

“They finally dropped the option in the face of EPA’s concern over the engine makers’ ability to ensure SCR’s use when a truck was operating, plus the lack of a distribution infrastructure for the mixture.”

If we read between the lines it looks like the use of SCR has not been abandoned, rather pushed back. See if you come to the same conclusion as we again quote from TT, “Diesel manufacturers have put the selective catalytic reduction aftertreatment process on hold, but the manufacturers said SCR would still be an option for 2010, when emission standards were set to change again.”

Final Conclusion

Again, I’ll remind you that I am not adept at predicting the future. However, we’ve provided a paint-by-numbers guide for the 2007 emissions picture; it’s up to you to fill in the colors. Will your picture match the one that Cummins and Dodge are painting? We’ve got about one year before the 2007 model year truck is introduced. Get busy with your brush.

Credits: Much of the technical information (abbreviation definitions and emissions solutions) was gleaned from Cummins bulletin number 4103666, “2007 Emissions: Choosing the Right Technology.” Copies of this bulletin can be sourced at your Cummins distributor or by calling 800-DIESELS.

OVER THE YEARS — DODGE TECHNICAL SERVICE BULLETINS

Not surprisingly, there have been comments by those unfamiliar with the truck (prospective new/used buyers, Internet, truck shows) that “the Turbo Diesel certainly has its share of problems.” To them, no doubt, the grass looks greener on the other side.

Although some will dwell on the problems, the majority of owners take initiative to solve/correct, anticipate/prepare for a future situation. That’s what the TDR is all about!

Thanks to the TDR membership group and the support from DaimlerChrysler and Cummins we are equipped with answers and solutions, rather than wonderment and isolation that would exist without a support group. My thanks goes out to the TDR members for being a supportive membership group.

DODGE TECHNICAL SERVICE BULLETINS

With the brief introduction out of the way, this is our review of Dodge Technical Service Bulletins issued in the previous years. For a given calendar year, all Dodge vehicle TSBs are published in book format and are available for purchase in

July/August. As a service, we purchase the TSB directory and then search through the book for only those bulletins relating to the Turbo Diesel truck.

In an effort to consolidate the TSBs for the magazine, we use the same index system categories as DaimlerChrysler. Below are the index categories.

2 Front Suspension	14 Fuel
3 Rear Axle	16 Propeller Shafts & U-Joints
5 Brakes	18 Vehicle Performance
6 Clutch	19 Steering
7 Cooling	21 Transmissions
8 Electrical	22 Wheels & Tires
9 Engine	23 Body
11 Exhaust	24 Air Conditioning
13 Frame & Bumpers	26 Miscellaneous

A note concerning the TSBs and their use: the bulletins are intended to provide dealers with the latest repair information. Often the TSB is vehicle identification number (VIN) specific. VIN data on the Chrysler service network helps the dealer in his service efforts. A TSB *is not* an implied warranty.

TECHNICAL SERVICE BULLETINS ISSUED DURING 1995 AND PRIOR

CATEGORY 2 FRONT SUSPENSION

<u>TSB#</u>	<u>MODEL</u>	<u>SUBJECT/DESCRIPTION</u>
02-05-95 5/15/95	'94 - '95 (BR) 4x4 4x2 Cab Chassis	<i>Rattling/clunk type noise from front of vehicle.</i> Verify that the stabilizer bar is built with the correct ball stud links. If necessary, the bulletin details the replacement of both stabilizer links with tapered ball stud links.
02-02-94 2/11/94	'94 (BR)	<i>Service manual revisions for torque values on front suspension.</i>
02-07-94 6/15/94	'94 (BR)	<i>This information bulletin differentiates the track bar used on different vintage trucks.</i>
02-08-94 7/22/94	'94 2500 (BR) Cab Chassis with sales code XBC	<i>Low ride height on 8800 GVW cab chassis.</i> The bulletin describes abnormal low ride height in the rear where the truck is loaded near GVW. It lists the parts necessary to replace the shocks and rear leaf springs.
02-20-94 12/2/94	'94 (BR)	<i>Service manual revision for torque values on stabilizer link bar.</i>
02-02-91 1/28/91	'90 - '91 (AD) 2WD vehicles only	<i>Front spring spacer for two wheel drive trucks.</i> The condition is a vehicle leaning or low on the left front corner. The repair involves the installation of a spacer (4322629) on the left coil spring to raise the left front corner approximately one inch.
02-06-90A 12/17/90	'90 - '91 (AD) 2WD vehicles only	<i>Front spring spacer for two wheel drive trucks.</i> The condition is a vehicle leaning or low on the left front corner. The repair involves the installation of a spacer (4322629) on the left coil spring to raise the left front corner approximately one inch.
02-09-90 11/19/90	'89 - '90 (AD) 4WD	<i>Service manual revision for camber specification.</i>

CATEGORY 3 REAR AXLE

<u>TSB#</u>	<u>MODEL</u>	<u>SUBJECT/DESCRIPTION</u>
03-03-95 5/5/95	'94 - '95 (BR)	<i>Rear axle trac-loc chatter.</i> This bulletin supersedes 03-01-94 (7/8/94) and applies to trac-loc Dana model 60, 70 and 80 axles. The symptom is chatter while turning corners. The bulletin involves draining and refilling the axle with new fluid and trac-loc additive. It is important that gear oil 4796517 and trac-loc additive 4318060 be used.
03-02-93 5/7/93	'92 - '93 (AD)	<i>Launch shudder/vibration.</i> For 1992-1993 131" or 149" wheelbase trucks. Describes repair procedure to adjust the pinion angle of the rear-end to eliminate vibration or shudder in the 1-2 shift made at medium to heavy throttle. This TSB does not address "wheel hop" that occurs with manual transmission trucks at start off. Wheel hop is a function of driveline spring wrap up because of high torque being exerted on the pinion shaft.

CATEGORY 5**BRAKES**

<u>TSB #</u>	<u>MODELS</u>	<u>SUBJECT/DESCRIPTION</u>
05-09-95 B 9/22/95	'94-'95 (BR) All 4x4 and 3500 4x2 Club Chassis only	<i>Drift left or right under moderate or hard braking.</i> The symptom is a drift right or left during moderate to hard brake applications just short of antilock operation. The condition is more evident with worn brakes. The steering wheel remains straight ahead - truck drifts. The repair is <u>not</u> to correct a condition where the steering wheel moves during the drift. If steering wheel moves, a brake system inspection, according to the service manual, is in order. The repair involves installing shems between the wheel and (2500) hub/bearing assemble, (3500) hub extension as required.
05-02-95 3/24/95	'94-'95 (BR) 3500 4x4/4x2 2500 4x4	<i>Front brake noise on trucks with 86 mm diameter caliper pistons.</i> The symptom is a squeal noise when applying the brakes for a normal stop. The repair involves grinding or filing a chamfer on both ends of the front brake pads.
05-03-94 3/4/94	'94 (BR)	<i>Service manual revision for brake bleeding procedure on trucks equipped with ABS brakes.</i>
05-21-94 10/21/94	'89-'93 (AD)	<i>Premature brake wear on trucks with 12" brake drums.</i> The bulletin involves replacement of the rear brake shoes (linings) with revised shoes.
05-08-93 A 9/3/93	'94 (BR)	<i>Pedal feel/characteristics of ABS brakes is the subject of this information only bulletin.</i>
05-15-93 11/1/93	'94 (BR)	<i>Brake pedal noise.</i> The symptom is a squawk caused by the metering valve spring chattering when the brake is depressed. The bulletin involves the installation of a revised metering valve.
05-04-92 A 4/21/92	'89-'92 (AD) sales code BKH, BKJ	<i>Premature brake wear on trucks with 12" brake drums.</i> The bulletin involves replacement of the rear brake shoes (lining) with revised shoes.
05-01-91 1/28/91	'81-'91 (AD)	<i>Rear wheel anti-lock speed sensor connector repair procedure.</i> If a red/amber ANTILOCK warning light illuminates and a code 9 diagnostic code is found, a possible cause is the connector for the RWAL speed sensor. The bulletin describes the repair procedure and parts needed to correct the problem.
05-05-91 8/12/91	'81-'91 (AD)	<i>Front disc brake noise from Bendix disc brakes.</i> The bulletin applies to trucks with Bendix disc brakes (3.38" caliper pistons). Noise can occur and the repair involves grinding a chamfer on both ends of the outboard brake pad.
05-07-90 9/24/90	'89-'90 (AD)	<i>Rear wheel anti-lock faults caused by water contamination.</i> A possible cause for illumination of the BRAKE and ANTILOCK warning lamps could be water contamination of the 4-way connector at the hydraulic valve and/or at the 50-way connector. The bulletin describes the repair and parts necessary to add a service jumper harness to the existing harness.

CATEGORY 6**CLUTCH**

<u>TSB #</u>	<u>MODELS</u>	<u>SUBJECT/DESCRIPTION</u>
06-01-94 8/12/94	'89-'93 (AD) with manual transmission	<i>Transmission noise below 1400 rpm.</i> The bulletin describes a powertrain induced cyclic noise condition that appears to be transmission/driveline related. Especially noticeable in 4th and 5th gears, the noise occurs below 1400 rpm during coast or light throttle. The noise is not damaging to the powertrain and is due to the dampening characteristics of the clutch springs. The revision, if needed, involves replacement of the clutch disc. <i>Transmission noise below 1400 rpm.</i>
06-01-90 A 12/31/90	'89-'93 (AD) with manual transmission	The bulletin describes a powertrain induced cyclic noise condition that appears to be transmission/driveline related. Especially noticeable in 4th and 5th gears, the noise occurs below 1400 rpm during coast or light throttle. The noise is not damaging or durability related. The diagnosis involves a road test to pinpoint the rpm at which the noise occurs. The revision involves a change of the flywheel.

CATEGORY 7**COOLING**

<u>TSB #</u>	<u>MODELS</u>	<u>SUBJECT/DESCRIPTION</u>
07-04-94 4/8/94	'94 (BR)	<i>Service manual revision - thermostat seals.</i> Revised service manual pages showing t-stat seal pictures.
07-07-94 9/30/94	'94-'95 (BR)	<i>Engine slow to warm-up in cold ambient temperatures.</i> The bulletin describes an overcooling condition caused by the thermostat being stuck in a partial open position. Gauge fluctuation is addressed and is considered normal with no action required. Owners are advised that the cooling system is large to provide capacity and protection for high temperatures and high GCWR ratings. Slower warm-ups are to be expected.
07-01-91 1/28/91	'89 '90 (AD)	<i>Overheating or no heat condition.</i> An interference between the thermostat and cylinder head coolant passage on engines built before engine serial number 44465181 may result in a stuck t-stat in the open or closed position. A revised t-stat and coolant passage diameter check a part of the repair procedure.
07-04-91 9/23/91	'89-'93 (AD)	<i>Lower radiator hose leakage.</i> Some leakage from the lower radiator hose at the waterpump connection may occur due to a step cast in the water pump nipple. The repair involves installing a second hose clamp.
07-05-91 12/16/91	'91 (AD)	<i>Fan belt noise/chirp.</i> The noise is caused by excessive paint in the grooves of the water pump allowing the belt to slip. Wire brush and solvent to remove the paint is the repair procedure.
07-03-90 12/21/90	All	<i>Recycled engine coolant.</i> The use of "reconstituted" antifreeze/coolants is not authorized in the performance of any repair covered under the provisions of warranty.
07-01-89 2/27/89	'88 - '89 with automatic transmission	<i>Premature brake wear on trucks with 12" brake drums.</i> The bulletin involves replacement of the rear brake shoes (lining) with revised shoes.
05-01-91 1/28/91	'81-'91 (AD)	<i>Auxiliary oil cooler freeze-up.</i> At ambient temperatures of -10°F or lower, trucks with auxiliary coolers (NHB) may lose transmission fluid due to a restriction of oil flow. A bypass line is the recommended repair.

CATEGORY 8**ELECTRICAL**

<u>TSB #</u>	<u>MODELS</u>	<u>SUBJECT/DESCRIPTION</u>
08-25-95 6/9/95	'94-'95 (BR)	<i>Power mirror vibration associated with installation of "bugscreen" deflectors.</i> The symptom is blurred images in the power mirrors. The diagnostic procedure - remove the bugscreen. If vibration ceases the mirrors are ok. Bugscreen deflectors are designed to disrupt airflow which can lead to mirror/antenna vibration.
08-24-95 9/30/95	'94 - '95 (BR)	<i>Accessory frame ground jumper wire.</i> The bulletin discusses a frame ground jumper wire from the battery negative to the frame bumper bracket be added if electrical accessories (winch, lights, snow plow, etc.) are added to the vehicle.
08-22-95 5/12/95	'94 - '96 (BR) '89 - '93 (AD)	<i>Installation of radio equipment.</i> The bulletin supersedes 08-31-94, 7/15/94 and discusses the proper installation of communication equipment in Chrysler vehicles.
08-16-95 A	'94 - '96 (BR) '89 - '93 (AD)	<i>Speed control - over/undershoot during set of speed selection.</i> The bulletin discusses the "adaptive strategy" that compensates for vehicle-to-vehicle variations in speed control cable lengths. Pressing the "set" button without pressure on the accelerator pedal can cause speed fluctuations. Proper review of the condition with vehicle operator is recommended.
08-05-94	'94 (BR)	<i>Poor AM radio reception.</i> Tighten the antenna base to 70 in/lbs to assure reception.

CATEGORY 8**ELECTRICAL**

TSB #	MODELS	SUBJECT/DESCRIPTION
08-06-94 2/4/94	'94 (BR)	<i>Infinity radio (code RAY) loses sound on right channel speakers.</i> Infinity (RAY) cassette with equalizer system may lose the sound of right side speakers. RAS code radios are not affected. An exchange radio is the repair.
08-08-94 A 5/20/94	'94 (BR)	<i>Weak sounding horn.</i> The bulletin discusses an upgrade from a single horn to a dual horn system.
08-10-94 2/18/94	'94 (BR)	<i>Fuel gauge sticks.</i> The bulletin covers replacing the fuel pump module, if the fuel gauge intermittently sticks at full, with less than full capacity.
08-17-94 4/1/94	'94 (BR)	<i>Battery drain on vehicles equipped with trailer tow package.</i> Water may collect in the 7 pin trailer tow connector housing causing corrosion. Exterior or interior lights may erratically operate regardless of switch operation. Inspect the tow connector and notch the connector to allow for drain.
08-29-94 6/24/94	'91-'93 (AD)	<i>Diesel secondary battery does not charge—vehicles built prior to 2/14/94.</i> Corrosion at battery clamp to secondary battery may prevent charging. Inspect, test, and replace battery clamp bolt if necessary.
08-33-94 7/15/94	'94-'95 (BR)	<i>Fuel gauge inaccuracy.</i> If the fuel gauge reads inaccurately (too much reserve when the tank gauge reads empty), a revised fuel sending unit may be necessary.
08-41-94 8/5/94	'94-'95 (BR)	<i>Trailer tow brake wire location.</i> An information only bulletin showing the wiring provisions for an electric brake actuator.
08-64-94 11/4/94	'94-'95 (BR)	<i>Power mirror vibration.</i> On vehicles equipped with power mirrors built prior to 9/18/94 this TSB discusses the diagnosis and repair for excessive vibration/blurred images.
08-65-94 11/4/94	'94 (BR)	<i>Poor AM radio reception.</i> On vehicles built prior to 12/01/93 poor AM reception can be repaired by replacement of the antenna base and cable assembly.
08-05-93 2/8/93	'93 (AD)	<i>White smoke at start-up.</i> Service changes to the powertrain control module (SEBC) may cause white smoke at start-up. The SEBC is programmed to eliminate operation of the air intake heater for the first 25 vehicle starts. After service or in pre-delivery situations, there may be vehicles that have not accumulated 25 starts. The white smoke condition should be resolved after 25 starts are accumulated.
08-07-93 A 3/19/93	'92-'93 (AD) with four wheel drive	<i>Speed control surge.</i> The bulletin describes the correct speed control servo and cable match for the powertrain control module. Verify compatibility of components. Replace speedometer drive gear, if necessary.
08-45-93 10/8/93	'94 (BR)	<i>Radio lock-up.</i> The bulletin applies to AM/FM Stereo (RAL) or AM/FM stereo cassette (RAS) radios. If the buttons and controls do not function the condition is caused by a programming error. The condition is corrected by following the operational sequence outlined in the TSB.
08-47-93 10/15/93	'94 (BR)	<i>Erratic coolant temperature gauge reading.</i> The cooling system on the Cummins diesel engine equipped vehicles provide for capacity and protection at high GCWR. The large capacity can cause slower than normal warm-up. Also temperature gauge reading fluctuations are normal.
08-58-93 12/10/93	'91-'93 (AD)	<i>Fuel gauge inaccuracy.</i> Too much reserve fuel in the tank when the gauge indicates empty may be the fault of an incorrect sending unit. The repair involves a wiring harness and sending unit change.

CATEGORY 8**ELECTRICAL**

<u>TSB #</u>	<u>MODELS</u>	<u>SUBJECT/DESCRIPTION</u>
08-67-93	'94 (BR)	<i>Service procedure for the stop light switch connector.</i> An information only bulletin showing the disconnect procedure of the stop light switch.
08-05-91 4/22/91	All trucks	<i>Trailer tow wiring installation.</i> The information only bulletin gives guidelines for proper wiring of trailer tow wiring packages.
08-10-91 9/9/91	'89-'91 (AD)	<i>Speedometer reading fluctuates and/or the speed control disengages.</i> The condition may be caused by spread female connectors at the 2-way distance sensor connector. Inspect and replace as necessary.
08-11-91 10/7/91	'91 (AD)	<i>Fuel reads low when fuel tank is full.</i> If fuel gauge does not read full after filling the fuel tank, the problem may be an incorrectly calibrated fuel sealing unit. Repair and replace as necessary.

CATEGORY 9**ENGINE**

<u>TSB #</u>	<u>MODELS</u>	<u>SUBJECT/DESCRIPTION</u>
09-10-95 6/2/95	'94-'95 (BR)	<i>Diagnosing oil consumption.</i> The concern is an operator report of greater than one quart per one thousand miles. Variations in oil level are likely possible if the oil check is performed on a warm engine due to slow drain back from the inline fuel pump. Discuss with customer and assure dipstick is updated to part number 4796874. The correct dipstick increases the safe zone to two quarts versus the early '94 vintage dipsticks with only a one quart safe zone.
09-04-95 4/14/95	'94-'95 (BR)	<i>Excessive oil drainage from oil draft (breather) tube.</i> The bulletin applies only to engines built prior to 12/1/94. It involves replacing the tappet cover with a new sealed version.
09-06-94 4/22/94	'94 (BR)	<i>Cummins exhaust manifold gaskets.</i> Service gaskets and production gaskets can vary in thickness. Do not intermix. If an exhaust gasket requires replacement, then replace all six.
08-65-94 11/4/94	'94 (BR)	<i>Service manual revision for Cummins piston grading procedure.</i> The information only bulletin details the pistons to be used if engine rebuild is necessary.
09-07-91 12/2/91	'91-'92 (AD)	<i>Cylinder head bolt torque tightening procedure.</i> The information only bulletin describes the bolt tightening procedure for cylinder head bolts.
09-11-89 7/3/89	'89 (AD) with automatic transmission	<i>Knocking noise at rear of engine due to a cracked torque converter drive plate.</i> On trucks built prior to 2/8/89 if there exist a knocking or grinding noise at the rear of the engine check, the torque converter drive plate for cracking. Replace as necessary.

CATEGORY 11**EXHAUST**

<u>TSB #</u>	<u>MODELS</u>	<u>SUBJECT/DESCRIPTION</u>
11-03-94 5/13/94	'94 (BR)	<i>Diesel exhaust stains.</i> The bulletin applies to 5-speed trucks built prior to 2/1/94 and automatic trucks between 2/1/94 and 10/1/94. The condition is exhaust soot on the side of the truck. A tail pipe extension is the part needed to remedy the situation.
08-47-93 10/15/93	'94 (BR)	<i>Rear tailpipe support bracket cracking.</i> The condition is a rattle noise caused by a crack or break in the rear tailpipe support bracket area. A revised tailpipe support bracket (5 2018458) is the part used for repair.

CATEGORY 14**FUEL**

<u>TSB #</u>	<u>MODELS</u>	<u>SUBJECT/DESCRIPTION</u>
14-05-94 4/8/94	'94 (BR) '89-'93 (AD)	<i>Use of low sulfur fuel.</i> The bulletin discusses the new for 1994 low sulfur fuel. Fuel lubricity concerns are addressed as the use of diesel fuel additives to increase the lubricity of low sulfur fuel are not required.
14-15-93	'89-'93 (AD)	<i>Fuel leakage from the roll-over valve vent.</i> The bulletin warns that repeated attempts to force fuel into the tank after the automatic shut off has engaged may lead to a condition where the fuel level in the tank is above the designed operating level. Fuel may leak out of the roll over valve in this situation. The repair involves raising the roll over vent location by installing fuel hose to the vent nipple and routing to a high location along the filler tube.
14-02-90 12/3/90	'89-'90 (AD)	<i>Accelerator pedal effort too high.</i> The bulletin describes the installation of revised parts to lessen the pedal effort. If the truck has a Mopar aftermarket speed control kit, the kit already has the revised parts.
14-01-89 10/2/89	'89 (AD)	<i>Injection pump diagnosis procedure.</i> A troubleshooting procedure is outlined to help diagnose diesel engine problems.

CATEGORY 16**PROPELLOR SHAFTS & U-JOINTS**

<u>TSB #</u>	<u>MODELS</u>	<u>SUBJECT/DESCRIPTION</u>
08-05-93 2/8/93	'94-'95 (BR) automatic transmission trucks	<i>Droaning noise/vibration.</i> The symptom/condition is a droaning type noise and/or vibration felt in seat track, floor pan or steering column. The noise is worst case when pulling a camper or trailer with significant wind drag. Peak noise level is 1900 rpm for 4x2 trucks 1850 rpm on 4x4 models with torque converter clutch engaged. The repair involves replacement of the propeller shaft.
16-01-94 10/14/94	'94-'95 (BR)	<i>Shudder at start on vehicles with two piece driveshafts operated at near maximum GVW.</i> The symptom is a driveline shudder when pulling away from a stop. As the vehicle is loaded, the driveline angle will change. In the case of maximum GVW, the rear differential may rise above the rear driveshaft center bearing. The alignment could cause a shudder in the driveline. The repair involves replacement of the driveshaft center support bearing bracket and/or driveshaft.

CATEGORY 18**VEHICLE PERFORMANCE**

TSB #	MODELS	SUBJECT/DESCRIPTION
18-29-95 A 10/16/95	'94-'95 (BR) with automatic transmission	<i>Diesel low power/performance specs.</i> The bulletin applies to automatic transmission trucks with a customer complaint of slow acceleration or low power. Performance tests (0-60) are performed and an acceleration table to reference is provided. The bulletin guides the dealership through a series of trouble shooting tests to troubleshoot the low power complaint. Checks for wide open throttle, a low pressure fuel system check, and finally, an injection pump timing adjustment are described.
18-01-94 1/14/94	'94 (BR) with automatic transmission	<i>Lack of power/harsh transmission shifts.</i> The bulletin applies to vehicles built before 10/28/93 and involves the replacement of the throttle control lever to ensure full throttle travel. Also, adjustment of the throttle position sensor is described.
18-10-94 A 7/29/94	'94 (BR)	<i>Excessive White Smoke/Low Power.</i> The bulletin involves a diagnostic check of the cooling system and starting instructions before verifying timing of the engine. Manual transmission engines are set to 12.5 degrees top dead center. Automatic engines should be set according to the engine data plate.
18-05-93 4/30/93	'91-'93 (AD)	<i>Poor performance/lack of power.</i> The bulletin discusses the troubleshooting procedures for a poor performance complaint. After verification of engine system performance, the bulletin outlines the criteria for a torque converter stall test for automatic equipped trucks and a 20-50 mph test for manual transmission trucks. An adjustment procedure for the LDA (a timing advance that is controlled by boost pressure) is described. The bulletin is known as the "starwheel" or "balloon test" by service technicians.
18-06-92 A 7/23/93	'91-'93 (AD) with automatic transmission	<i>Erratic 3-4 or 4-3 shifts.</i> The bulletin discusses erratic shifting (hunting) between third and fourth gear. The shift schedule is based on several inputs to the powertrain control module (SEBC). Diagnosis of the components is described. If a throttle position sensor is required the replacement part number is 4746966.
18-05-92 6/15/92	'92 (AD)	<i>Vehicle surging when cruise control is engaged.</i> The condition may be caused by the calibration of the powertrain control module (SEBC). Replacement of the SEBC is covered in the repair procedure.
18-06-92 6/29/92	'91-'92 (AD)	<i>Lack of power, poor acceleration in cold ambient temperatures.</i> Below 33°F some vehicles may be slow to accelerate or feel low on power. The condition may be caused by ice forming at the fuel intake area of the fuel gauge sending unit module. A revised module part number and repair procedure are outlined.
18-10-92 A 9/8/92	'91-'92 (AD) with automatic transmission	<i>Erratic 3-4 or 4-3 shifter.</i> Note: See TSB 18-06-93 A
18-11-92 7/13/92	'91-'92 (AD)	<i>Poor performance/lack of power.</i> Note: See TSB 18-05-93
18-17-92 9/8/92	'91 (AD)	<i>Engine rpm fluctuates when the cruise control is engaged.</i> This bulletin is for non-intercooled (build date prior to 1/1/91) trucks. The bulletin involves replacing the vehicle speed control module with a recalibrated module.
18-18-92 10/19/92	'91-'92 (AD)	<i>Poor engine performance/erratic engine operation/transmission operation.</i> Some vehicles may exhibit the above characteristics as well as transmission hunting. Corrosion or spreading of the female terminals in the 3-way throttle position sensor connector could be the problem. Diagnosis and repair as necessary.
18-15-92	'91 (AD)	<i>White smoke at start-up.</i> At cold ambient conditions white smoke can be a condition. This bulletin applies to trucks built after 1/1/91. The repair involves replacing the air temperature sensor. If the engine serial number is higher than 44623028 the sensor is of the new design.

CATEGORY 19 STEERING

TSB #	MODELS	SUBJECT/DESCRIPTION
19-02-05 B 11/3/95	'94-'95 (BR) trucks with a build date prior to 1/1/95	<i>Clunk or rattle felt in steering wheel/column over rough surfaces or while making a turn.</i> The repair involves performing an inspection of suspension and steering components to assure proper torque. The replacement of the steering column intermediate shaft is described.
19-01-94 1/28/94	'94 (BR) 4x4	<i>Slow steering return.</i> The bulletin applies to 4x4 trucks with a Dana 60 axle. The diagnosis involves using a spring scale to determine turning force. The repair involves performing a ball joint tightening.
19-04-94 6/3/94	'94 (BR)	<i>Low power assist in cold ambient temperatures.</i> The condition can be minimized by reviewing the cold start procedures. Cold climate power steering fluid (pn 04778524) may be used.
19-03-93 4/16/93	'89-'93 (AD)	<i>Steering Column coupler.</i> A repair package with a revised boot has been developed to service the steering coupler. The part number is 4740761. This is an information only bulletin.
19-02-91 4/22/91	'89-'91 (AD) with four wheel drive	<i>Steering wheel off-center.</i> Due to a shift in the steering gear bracket in high load conditions, the steering wheel may be off center during straight driving. The repair involves installing a shoulder bolt that acts as a dowel pin locking the steering gear bracket to the frame.

CATEGORY 21 TRANSMISSION

TSB #	MODELS	SUBJECT/DESCRIPTION
21-02-95 3/31/95	'95 (BR) built after 3/20/95	<i>Quick connect removal and reconnect procedure.</i> The bulletin is an "information only" bulletin outlining two ways to disconnect the quick connectors of the automatic transmission lines.
21-03-95 A 6/16/95	'94-'95 (BR)	<i>Automatic transmission cold temperature cooler bypass kit.</i> The condition occurs at ambient temperatures of -15°F or below. Vehicles equipped with automatic transmission coolers may experience a lack of fluid flow to the transmission due to restricted cooler lines. In periods of extended driving transmission failure may result. The bulletin describes the installation of a cold weather transmission cooler by-pass kit. Caution is needed as the kit <i>decreases</i> the cooling capacity of the transmission when driving in hot ambient temperatures, and <i>is not</i> recommended.
21-04-95 4/14/95	'94-'95 (BR) trucks with automatic transmission	<i>Vibration or perceived engine miss.</i> The symptom is a vibration or perceived engine miss at approximately 1100 rpm as the torque converter clutch engages. The condition occurs in fourth gear lock-up at speeds between 42 to 48 mph. Depending on year model the powertrain control module is either replaced or reprogramed.
21-05-95 A 1/5/96	'94-'95 (BR) trucks with automatic transmission	<i>Delayed transmission engagement/torque convertor drainback.</i> The condition is delayed transmission engagement of 2 to 8 seconds at initial start-up. The problem is most noticeable after the vehicle has been parked for an extended period. The bulletin describes the installation of transmission lines with a one-way drainback valve.
21-08-95 1/30/95	'94-'95 (BR)	<i>Speed sensor oil seepage.</i> The bulletin describes how oil seepage can occur in the speed sensor area. The repair is the installation of a speedometer adapter.
21-09-95 6/30/95	'94-'95 (BR) trucks with manual transmission	<i>Servicing of 5th gear mainshaft nut on NV 4500 manual transmission.</i> The information only bulletin describes the replacement of the 5th gear main-shaft nut with a new nut if the original nut has to be removed. Under no circumstances is the original part to be reused. Special Mopar lock seal should be applied to the threads at reassembly.
21-11-95 7/7/95	'96 (BR) trucks with automatic transmission	<i>Overdrive unavailable in extreme cold temperatures.</i> The information only bulletin emphasizes a change to the PCM for 1996. For '96 in ambient temperatures of -5°F and below the PCM inhibits the transmission from shifting into overdrive. This protects the transmission from damage if the fluid would begin to freeze. The PCM will allow overdrive once the ambient temperature has risen approximately 7° above the temperature the ID was inhibited at.

CATEGORY 21**TRANSMISSION**

TSB #	MODELS	SUBJECT/DESCRIPTION
21-04-94 3/4/94	'94 (BR) with manual transmission NV 4500 HD	<i>Transmission shift lever stuck in or blocked out of 5th gear/reverse.</i> The shift lever does not shift out of 5th or reverse gear position, or the shift lever will not go into 5th/reverse. Diagnose the transmission and, if necessary, replace the transmission overdrive rail, lug shift fork, and synchronizer.
21-10-94 5/27/94	'94 (BR) with manual transmission NV 4500 HD	<i>Shift lever contacts instrument panel.</i> Inspect the shift lever to transmission stub shaft connection. Reseat the lever to the stub shaft if necessary.
21-17-94 9/16/94	'94 (BR), '93 (AD) with automatic transmission	<i>Transmission diagnostic reference supplement.</i> To assist in the repair of automatic transmission, the information only bulletin, lists symptom/cause/correction information.
21-18-94 9/30/94	'94 (BR), '89-'93 (AD) with automatic transmission	<i>Transmission 4-3 downshift clunk.</i> A driveline clunk or harshness occurs during 4-3 coast downshift repair as described in bulletin.
21-24-94 12/2/94	'94-'95 (BR) with automatic transmission	<i>Shift linkage adjustment.</i> The information only bulletin explains how to correct a PRNUL misalignment.
21-25-94 12/23/94	'94-'94 (BR) with NP 241 HD transfer case	<i>High effort when shifting from 2WD high to 4WD high in cold temperatures.</i> If high effort condition occurs when shifting the transfer case in cold temperatures, the bulletin describes the repair. The procedure involves a change in the front axle lubricant or possibly a parts component replacement.
21-23-93 9/3/93	'92-'93 (AD) with automatic transmission	<i>Lack of 3/4 up-shift and deep throttle 2/4 up-shift.</i> A complaint of lack of 3/4 up-shift at 50 to 60 mph on the '92 MY trucks or complaint of deep throttle 2/4 up-shift on late built '92 and '93 models could be related to the overdrive shift calibration. Using the DRB scan tool verify the engine and transmission systems are functioning properly. The powertrain control module (SEBC) may require replacement to updated part number 4746568.
21-39-93 12/31/93	'89-'93 (AD) with automatic transmission	<i>Four speed automatic transmission 4-3 downshift clunk.</i> The bulletin describes a clunk or harshness during 4-3 coast downshift at approximately 18-20 mph. Verify all engine and transmission systems are functioning properly. Repair as required.
21-18-92 11/30/92	'92-'93 (AD) with automatic transmission	<i>Delayed up-shifts and harsh engagement into drive or reverse.</i> The bulletin describes a repair involving adjustment of the throttle valve cable and replacement of the return spring.
21-11-91	'89-'91 (AD) with A 518 automatic transmission	<i>3-4 up-shift noise with A 518 transmission.</i> A noise or rattle during 3-4 up-shift or down-shift may be the result of an overdrive clutch pack vibration. Diagnose the vehicle to confirm condition and repair as necessary.
21-05-90 2/26/90	'89-'90 (AD) with automatic transmission	<i>Replacement of transmission shift lever and stubshifter.</i> The shift lever and stub shifter are available as separate replacement parts. If replacement is required, use the component parts - do not replace the transmission assembly.
21-14-90 5/7/90	'90 (AD) with A 518 automatic transmission	<i>Low/reverse band wear.</i> Premature wear of the low/reverse band may be the result of one of the overdrive transmission mounting bolts making light contact with the band strut resulting in incomplete release of the band. A washer is installed to prevent contact.
21-12-89 5/1/89	'89 (AD) with manual transmission	<i>Speedometer drive gear replacement procedure.</i> An information only brochure to supplement the service manual.

CATEGORY 22 WHEELS & TIRES

TSB #	MODELS	SUBJECT/DESCRIPTION
22-03-95 3/3/95	'95 (BR)	<i>Match mounted tire/wheel combinations.</i> The bulletin is an "information only" bulletin describing a match mounting process to improve ride characteristics.
22-04-95 4/7/95	'94-'95 (BR)	<i>Spare tire winch operation.</i> The bulletin is an "information only" bulletin reminding not to use power tools to drive the spare tire winch.
22-05-95 A 6/30/95	'94-'95 (BR) with code WDC wheels	<i>Wheel runout measurement code WDC wheels procedures.</i> The bulletin gives the allowable remount and informs the dealer that the tire must be dismounted to correctly measure radial and lateral runout.
22-06-95 6/16/95	'95 (BR)	<i>Match mounting during wheel service.</i> The information only bulletin helps dealers match mount wheels and tires. Premature rust on chrome wheels.
22-03-94 6/24/94	'94 (BR)	<i>Wheels manufactured after 1/1/94 have an improved chrome plating process. Wheels prior to 1/1/94 may show signs of premature rust.</i> Replacement of the wheels is described
22-05-93 7/16/93	'93 (AD)	<i>Tire and wheel runout.</i> A quick reference chart is provided for dealer diagnosing.
22-02-92 4/6/92	'89-'92 (AD)	<i>Wheel vibration on 350 Series trucks with flange type lug nuts.</i> Wheel/tire vibration may be caused by the wheels being off center on the wheel studs. The repair involves a wheel centering procedure using two 90° cone nuts.

CATEGORY 23 BODY

TSB #	MODELS	SUBJECT/DESCRIPTION
23-04-95 2/10/95	'94-'95 (BR)	<i>Rattle due to seat belt latch plate bumping trim.</i> The symptom is a noise due to the seat belt latch bumping against the trim when the belt is not in use. The repair involves the addition of a sound deadener pad to the trim panel.
23-29-95 6/9/95	'94-'95 (BR)	<i>Cracked sunvisor support bracket/retainer.</i> The bulletin involves the replacement of the visor bracket with a revised bracket.
23-43-95 6/14/95	'94-'95 (BR)	<i>Door operation not smooth or feels loose.</i> Visually inspect the door hinge area. If the door hinge bushing has fallen out the bushing should be reinstalled and crimped to prevent recurrence.
23-52-95 A	'94-'95 (BR) Standard cab only	<i>Creaking noise or exterior noise from back of cab.</i> The condition is a sheet metal creaking or exterior noise from the back of the cab caused by vertical or horizontal cracks in cab back. Using a hoist and a strong light, look for cracks on lower portion of cab. If cracks are noted four cab reinforcements and replacement cab isolators should be installed.
23-74-95 12/8/95	'95-'96 (BR)	<i>Interior film build-up on windows.</i> Window film build-up is caused by vinyl interior trim material releasing gasses that adhere to the glass. The condition lessens as the vehicle gets older.
23-08-94 1/28/94	'94 (BR)	<i>Wind noise at front of door.</i> Inspect the vehicle for the appropriate seal. If not present, perform the repair/installation procedure
23-32-94 4/1/94	'94 (BR)	<i>Door fit at roof line.</i> The top of the door should project higher than the roof panel. Do not attempt a repair if the door falls within the overflush 1-3 mm condition.

CATEGORY 23**BODY**

TSB #	MODELS	SUBJECT/DESCRIPTION
23-36-94 4/22/94	'94 (BR)	<i>Front door to windshield moulding squeak/creak.</i> A noise from the front of door/plastic windshield moulding can occur. The correction is to install anti-friction tape to the inside edge of the doors.
23-39-94 5/6/94	'94 (BR)	<i>Pickup box floor rattle.</i> The bulletin involves applying sealer to the pickup box floor at the crossmember.
23-40-94 A 5/6/94	'94 (BR)	<i>Door glass rattle.</i> If the door glass rattles when the door is closed and the window is open the bulletin describes the diagnosis and repair of the weather strips.
23-41-94 5/13/94	'94 (BR)	<i>Creak noise from instrument panel bezel.</i> If a creaking noise occurs, coming from the instrument panel bezel, add felt tape to dash to dampen/isolate the components.
23-45-94 6/3/94	'94 (BR)	<i>Snapping noise at right side of instrument panel.</i> A snapping noise (sounds like a small stone hitting the window) may occur. If diagnosed, add a pad to the stiffening rib of the instrument panel to isolate the components.
23-49-94 7/1/94	'94 (BR)	<i>Warped tailgate.</i> Vehicles built at the Warren truck assembly plant (Dodge City complex) between 1/10/94 and 2/15/94 are suspect. Inspect as tailgate may be twisted or warped on the right side. Check the "run number" for date of production. Check the last three digits as 02X through 05X are suspect. Replace as necessary.
23-51-94 7/1/94	'94 (BR)	<i>Tailgate rattle.</i> If a tailgate rattle is heard, inspect the tailgate pivot bracket. Repair as described in bulletin with replacement stud and bearing mount.
23-60-94 8/12/94	'94 (BR)	<i>Popping or snapping noise from windshield.</i> The condition is a noise from the base of the windshield while traveling over rough roads/irregular surfaces. The repair involves removing windshield spacers at the base of the windshield.
23-63-94 8/26/94	'89-'93 (AD)	<i>Cowl cracks.</i> The condition is cracking or popping sounds from the cowl area at the lower corners of the windshield. Inspect the area underneath the fender at the cowl welds. The fenders must be removed to see the cracks. The repair involves installing cowl reinforcement brackets to the cowl.
23-68-94 9/30/94	'94-'95 (BR)	<i>Glue seeps out at backlight or windshield moulding.</i> Hot melt glue (clear to light brown) can seep out at the edge of the light or molding. The repair is to clean the glue with Mopar Concentrated Windshield Washer Solvent.
23-71-94 10/7/94	'95 (BR)	<i>Tailgate latch handle loose.</i> The bulletin applies to vehicles built from 8/30/94 to 9/8/94. The hole in the tailgate was stamped oversize. Inspect the latch handle and apply Mopar Bond-All Gel Adhesive to correct.
23-73-94 10/7/94	'94 (BR)	<i>Cup holder rattle.</i> If cup holder rattles in the closed position, add a foam block to the back of the mug holder.
23-95-94 A 12/30/94	'94-'95 (BR)	<i>Front seat cover wear through above the recliner pivot.</i> The condition is wear-through at the recliner pivot. Inspect as directed and repair if necessary.
23-98-94 12/23/94	'94 (BR)	<i>Tailgate hard to latch in cold temperatures.</i> If the tailgate is difficult to latch when ambient temperatures are below freezing, the strikers should be checked for proper adjustment. If the problem persists, replace the caliper stop with a shorter one, part number 55075773.

CATEGORY 23**BODY**

TSB #	MODELS	SUBJECT/DESCRIPTION
23-101-94 12/30/94	'94-'95 (BR)	<i>Anti-friction tape on A-pillar.</i> Bulletin 23-36-94 described a squeak and paint abrasion at the door to windshield A-pillar area. Anti-friction tape is now being applied at the assembly plants to prevent the problem. Do not remove the anti-friction tape.
23-57-93 10/8/93	'94 (BR)	<i>Instrument panel creak.</i> A creak or squeak may be present on the left side of the instrument panel. The repair involves loosening of the instrument panel to provide additional clearance between the cowl side panel and instrument panel support joint.
23-64-93 11/19/93	'94 (BR)	<i>Tailgate rattles.</i> If tailgate rattles over bumps, check for looseness. If tailgate does not close tightly, replace the overslam and alignment bumpers.
23-21-92 9/8/92	'93 (AD)	<i>'93 standard paint colors.</i>
23-09-91 8/26/91	'92 (AD)	<i>'92 standard paint colors.</i>
23-12-90 10/8/90	'91 (AD)	<i>'91 standard paint colors.</i>
23-24-89 10/10/89	'90 (AD)	<i>'90 standard paint colors.</i>
23-08-89 4/10/89	'89 (AD)	<i>'89 standard paint colors.</i>

CATEGORY 24**AIR CONDITIONING**

TSB #	MODELS	SUBJECT/DESCRIPTION
24-01-95 A 3/3/95	'89-'94 (AD)	<i>R-12 to R-134a refrigerant adaptation procedure.</i> The bulletin describes the conversion from R-12 to R-134a. The procedure should only be performed on vehicles when R-12 is no longer available.
24-06-95 A 5/26/95	'94-'95 (BR)	<i>Odor from air conditioning ducts.</i> Some vehicles may emit a "musty" odor from the airconditioning ducts. The odor is most noticeable when the A/C system is first turned on. Two possible causes are discussed and repair procedure are outlined based on less than or greater than 12 months in service.
24-08-95 5/19/95	'94-'95 (BR)	<i>White flakes from instrument panel outlet.</i> Sodium silicate is used to coat the air conditioner evaporator for corrosion protection. If excessive amounts are applied during the manufacturing process, there is a tendency for the extra coating to flake off. Flakes may blow from the vents when the fan is turned on. The bulletin is issued for information only.
24-08-94 5/6/94	'94 (BR)	<i>A/C evaporator odor.</i> A "musty" odor may be emitted from the air conditioner ducts. The odor is most noticeable when the A/C is first turned on after the system has been left off overnight or longer. The odor is a result of foreign material accumulating in the evaporator area. The bulletin involves cleaning and disinfecting the A/C evaporator and housing.

CATEGORY 24 AIR CONDITIONING

<u>TSB #</u>	<u>MODELS</u>	<u>SUBJECT/DESCRIPTION</u>
24-01-95 A 3/3/95	'91-'93 (AD) '94-'95 (BR)	<p><i>A/C evaporation freeze-up or lack of cooling on cycling clutch of air conditioning system.</i></p> <p>Loss of A/C airflow and/or cooling while the blower fan continues to operate may occur. This bulletin discusses the role of the powertrain control module in the A/C system.</p> <p>The electrical signal from the A/C cycling clutch switch passes through the Powertrain Control Module (PCM) to engage and disengage the A/C clutch relay. If the PCM is not properly disengaging the A/C clutch via the relay, the compressor will stay on continuously and result in evaporator freeze-up. Also, the PCM may not energize the A/C clutch relay at all. This condition results in the lack of cooling from the A/C system.</p> <p>The PCM should be checked per the procedure in the appropriate Powertrain Diagnostic Procedure Manual. Diagnostic Trouble Code 33 (A/C clutch relay circuit) will be present when either of these conditions are caused by the PCM. It is important to perform the complete test sequence because there are other A.C clutch relay circuit components that could also cause or contribute to the condition.</p>
24-27-93 11/19/93	'91-'93 (AD) '94 BR	<p><i>Air conditioner compressor noise.</i></p> <p>A growling noise may be heard with the compressor running. Diagnose the condition as outlined and perform the repair procedure if necessary. The repair involves installing a revised compressor valve plate assembly.</p>

CATEGORY 26 MISCELLANEOUS

<u>TSB #</u>	<u>MODELS</u>	<u>SUBJECT/DESCRIPTION</u>
26-04-94 10/28/94	All	<p><i>Diagnostic procedure manuals.</i></p> <p>The bulletin gives a current list of available diagnostic procedure manuals. These manuals provide system information, step-by-step trouble shooting procedures, diagnostic and driveability tests, along with diagrams, illustrations and helpful charts to find and fix problems on Chrysler Corporation vehicles. These manuals can be ordered by calling 1-800-626-1523.</p>

TECHNICAL SERVICE BULLETINS ISSUED DURING 1996

CATEGORY 2 FRONT SUSPENSION

<u>TSB #</u>	<u>MODELS</u>	<u>SUBJECT/DESCRIPTION</u>
02-01-96A 5/31/96	'94-'96 (BR)	<i>Camper Special service kit.</i> The bulletin supersedes TSB 02-01-96 dated 3/15/96. The bulletin applies to body style codes 31, 32, and 62 with one of the listed GVW sales codes Z2B, Z3A, Z7B, Z8A or Z8B. The bulletin describes the parts and installation procedure for a special service kit developed for use by owners that consistently carry a box mounted camper. A rear stabilizer bar and auxiliary spring comprise the kit.
02-03-96 5/31/96	'94-'96 (BR)	<i>Creaking noise from rear of vehicle.</i> The diagnosis involves the inspection of the rear leaf spring assembly to verify the appropriate number of spring tip inserts are present. If tip inserts are broken or missing the repair procedure is detailed in the TSB.
02-04-96 6/21/96	'94-'96 (BR) Two Wheel Drive (2WD)	<i>Lower ball joint replacement.</i> This bulletin applies only to two wheel drive vehicles. It discusses the service differences in tack welded ball joints/control arms and non tack welded ball joints/control arms.
02-06-96 11/29/96	'94-'97 (BR) 4x4 only	<i>Track bar ball joint diagnosis.</i> The bulletin refers to the '97 Truck Service Manual and is a supplement to help the technician troubleshoot loose or worn steering components. The track bar ball joint previously did not have an inspection procedure.

CATEGORY 3 REAR AXLE

<u>TSB #</u>	<u>MODELS</u>	<u>SUBJECT/DESCRIPTION</u>
03-02-96 5/10/96	'94-'96 (BR) 2500 and 3500 4x2 trucks, Regular Cab, automatic transmission and two-piece propeller shafts.	<i>Shudder when pulling away from stop when operated at maximum GVW rating.</i> The bulletin is a supersession of bulletin 16-01-94. If the vehicle exhibits a driveline shudder while pulling away from a stop at maximum GVW rating, the bulletin describes the replacement of the two-piece driveline and center support bracket with a single piece assembly.
03-03-96 8/16/96	'94-'96 (BR) With automatic transmission and 5.9 Turbo Diesel engine. Note: '96 2500 club cab, 155 WB 4x4 with heavy duty transfer case built after 5/9/96 have the revised propeller shaft.	<i>Droaning noise/vibration.</i> The symptom typically occurs at maximum load and is engine speed specific - 1900 rpm for 4x2 models, 1850 rpm for 4x4 models with the truck in fourth gear and the torque converter clutch locked up. If the problem is identified, a repair procedure involving a revised propeller shaft with a yoke weight damper is described.

CATEGORY 5**BRAKES**

<u>TSB #</u>	<u>MODELS</u>	<u>SUBJECT/DESCRIPTION</u>
05-14-95 A 2/9/96	'95-'96 (BR)	<i>Brake pedal noise when depressed.</i> The symptom is a squawk type noise when the brakes are depressed. The repair involves installing a revised back-up plate into the brake combination valve.
05-02-96 A 11/15/96	'94-'97 (BR) 2500, 8800 GVW - sales code and 3500 built before 8/5/96	<i>Accelerated brake lining wear, front versus rear.</i> The bulletin supersedes TSB 05-02-96 dated 2/23/96. The bulletin adds the 3500 series truck and incorporates the use of revised brake linings. The bulletin discusses wear conditions. The repair procedure involves replacing possibly the front brake linings, rear brake linings, or rear wheel cylinders, depending on truck model and vehicle sales code.
05-08-96 9/13/96	'94-'96 (BR)	<i>Brake pedal rattle.</i> If a rattle is heard coming from the brake pedal area and is eliminated when pressure is applied to the side of the brake pedal, a repair procedure involving a "wave washer" is outlined.
05-09-96 10/4/96	All	<i>Brake noise.</i> The information only bulletin describes the normal noises that may occur with a properly operating system, ABS self check, trace squeak, grinding, groaning etc., noises are discussed.
05-10-96 12/13/96	'94-'97 (BR)	<i>Chassis dynamics diagnosis.</i> The bulletin discusses conditions where-by the vehicle may move to the right or left when not controlled by the driver. Several causes are cited (aftermarket wheels, road crown, cross winds, incorrect tire pressures, worn wheel bearings, etc.). Diagnosis involves testing the vehicle to determine if the drift is brake related. A brake system evaluation is outlined. Steering and suspension inspection is discussed. Suspension torque values for fasteners are discussed. A suspension geometry evaluation is outlined. Front end alignment specifications are provided. Wheel shim kits and installation of shims for 4x4 trucks is discussed.

CATEGORY 8**ELECTRICAL**

<u>TSB #</u>	<u>MODELS</u>	<u>SUBJECT/DESCRIPTION</u>
08-20-96 7/19/96	'94-'97 (BR)	<i>Cassette auto load error on RAS code radio.</i> This information only bulletin describes a condition where the radio may enter the cassette play mode without a cassette being inserted. The bulletin explains the correction and discusses the function of the Ignition Off Draw (IOD) fuse.
08-21-96A 10/18/96	'96 (BR)	<i>Wiring harness connector repair packages.</i> This information only bulletin helps the service technician by providing a part number listing for the correct electrical components per an assembly. It also gives a review of the diagnosis procedure for electrical components.
08-23-96 8/23/96	'94-'96 (BR) built prior to 12/15/96	<i>Clicking noise from speedometer.</i> If a clicking/ticking noise is heard coming from the instrument cluster area, the bulletin describes the repair procedure to replace the speedometer.
08-33-96 10/11/96	'94-'97 (BR)	<i>Trailer tow wiring information.</i> Chrysler Corporation has offered optional trailer tow packages on all '94 through '97 Dodge Ram Trucks and has made trailer tow packages available through Mopar for vehicles that were not built with the trailer tow package. Several changes to the trailer tow wiring have occurred since the truck was introduced. It also identifies flashers. This bulletin identifies the part numbers for the Mopar trailer tow packages required to adapt trailer wiring to a vehicle that did not have the trailer tow package installed as original equipment from the factory.
08-47-96 12/20/96	'97 (BR)	<i>Radio interference from buzzer module.</i> The condition is a buzzing noise in the rear radio speakers with the radio on/ignition on and the door ajar. If a buzzing noise is heard the repair involves replacing the buzzer module.

CATEGORY 9 ENGINE

<u>TSB #</u>	<u>MODELS</u>	<u>SUBJECT/DESCRIPTION</u>
09-07-96 6/7/96	'94-'95 (BR)	<i>Fuel injection pump oil supply bushing oil seepage.</i> If oil seepage is diagnosed, the bulletin describes the repair procedure using a special oil supply and removal tool.

CATEGORY 11 EXHAUST

<u>TSB #</u>	<u>MODELS</u>	<u>SUBJECT/DESCRIPTION</u>
11-05-96 8/23/96	'94-'97 (BR)	<i>Diesel turbocharger diagnostic procedure.</i> This information only bulletin guides the service technician thorough troubleshooting steps to properly diagnosis turbocharger situations. Normal/abnormal noises, oil leakage, acceleration and low boost, are topics discussed in the bulletin.

CATEGORY 14 FUEL

<u>TSB #</u>	<u>MODELS</u>	<u>SUBJECT/DESCRIPTION</u>
14-07-96 8/2/96	'94-'96 (BR)	<i>Low pressure fuel system diagnostic procedures.</i> Too low a fuel supply to the Bosch P7100 fuel pump can affect performance. Low rpm miss/instability, white smoke, hard starting, low power may be the result. This bulletin gives the technician additional information to assist in diagnosis of the above problems.

CATEGORY 8 ELECTRICAL

<u>TSB #</u>	<u>MODELS</u>	<u>SUBJECT/DESCRIPTION</u>
08-20-96 7/19/96	'94-'97 (BR)	<i>Cassette auto load error on RAS code radio.</i> This information only bulletin describes a condition where the radio may enter the cassette play mode without a cassette being inserted. The bulletin explains the correction and discusses the function of the Ignition Off Draw (IOD) fuse.

CATEGORY 18 VEHICLE PERFORMANCE

<u>TSB #</u>	<u>MODELS</u>	<u>SUBJECT/DESCRIPTION</u>
08-23-96 8/23/96	'96 (BR)	<i>Revised injection pump timing specifications.</i> A revision in the injection pump timing specification on Cummins engines with a CPL 2022 or 2023 should be utilized when checking or performing injection pump timing.

YOU MIGHT BE A FORD/CHEVY OWNER IF...*

1. You write off a radiator as a business expense.
2. Your truck is insured by Smith & Wesson.
3. There is a puddle in your driveway year-round.
4. Your stereo speakers used to belong to the Moonlight Drive-in Theater.
5. Your wife has ever said, "Come move this transmission so I can take a bath."
6. You read the *Auto Trader* with a highlight pen.
7. You've ever hit a deer with your truck, deliberately.
8. There are more than four hats in the rear window of your truck.
9. Directions to your house include "turn off the paved road."
10. Your hood ornament used to be a bowling trophy.

**From "You Might Be A Redneck If . . ." by Jeff Foxworthy. Foxworthy's "Southern" humor can be found at bookstores everywhere. Buy his books for some serious fun.*

CATEGORY 19 STEERING

TSB #	MODELS	SUBJECT/DESCRIPTION
19-01-96 2/9/96	'95-'96 (BR)	<i>Clunk or rattle felt in steering column/wheel.</i> The condition is a clunk or rattle in the steering wheel/column during slow turns or stops on some '95-'96 trucks. Diagnosis includes a check of all fasteners for the appropriate torque value.
19-05-96 8/30/96	'94-'96 (BR) 4x4 trucks with sales codes Z8A and Z8B and 4x2 cab chassis (Z3B) built before 5/15/96.	<i>Shimmy after striking a bump or pothole.</i> This bulletin supersedes TSB 19-04-95 (5/12/95). The bulletin discusses a sustaining vibration (shimmy) felt in the front end of the vehicle after striking a bump or pothole. The repair procedure involves replacing the steering damper, replacing the track bar (if necessary) and the addition of an auxiliary steering damper.
21-04-96 3/15/96	'96 (BR)	<i>Transmission will not upshift following a 3-2 downshift.</i> Under certain conditions the transmission will not upshift following a 3-2 downshift. In this condition, the engine will continue to operate at maximum governor speed in second gear until the throttle is reduced. The condition only occurs if the overdrive is "off." The repair involves reprogramming the powertrain control module with new software.
21-13-96 9/20/96	'96 (BR) 4x4	<i>Transfer case shifter buzz or clatter.</i> A buzz or clatter may be heard from the 4x4 shifter at an engine speed of approximately 2000 rpm. The repair involves the addition of an insulating plastic gate liner to the transfer case shifter.
21-15-96 11/8/96	'95-'97 (BR)	<i>Quick connect removal and reconnect procedure.</i> The information only bulletin describes the repair procedure for removal/reconnect of the transmission cooler line fitting on trucks built after 3/20/95 and superseded bulletin 21-02-95, 3/31/95.

CATEGORY 23 BODY

TSB #	MODELS	SUBJECT/DESCRIPTION
23-01-96 1/5/96	'94-'96 (BR)	<i>Replacement cargo box information.</i> This information bulletin list the revised part numbers for the 6.5 ft. and 8.0 ft. cargo box with a reinforced front box floor.
23-02-96 1/19/96	'94-'96 (BR)	<i>Creak or tick noise from right side instrument panel.</i> The noise can be reproduced by pushing on the instrument panel at the shelf above the glove box door. The repair involves the removal of a 3/10 rivet.
23-09-96 2/2/96	'96 (BR) Clubcab with a "J" in the VIN at position 11 and built prior to 10/6/95	<i>Seatbelt buckle difficult to engage with one hand.</i> The driver side power seat may have a seat belt buckle that may be difficult to latch. The repair involves replacement of the seatbelt buckle.
23-21-96 3/29/96	'94-'96 (BR)	<i>Tailgate difficult to close in cold weather.</i> At less than 5° F the tailgate latch stop bumper may be too stiff to allow for easy closure. Inspect and replace bumper stop.
23-27-96 4/19/96	'96 (BR)	<i>Windnoise (whistle) around grille area.</i> If vehicle exhibits a windnoise (whistle) at speeds of 45 to 85 mph the diagnosis involves checking the grille for a manufacturing code "CAV3." If there is not a CAV3 stamp than the grille is not likely the source of the noise. If noise is from the grille, the repair involves adding 1/4" foam tape between the grille and hood.

CATEGORY 23**BODY**

<u>TSB #</u>	<u>MODELS</u>	<u>SUBJECT/DESCRIPTION</u>
23-29-96 5/10/96	'94-'96 (BR)	<i>Tailgate cracking on top inner ends.</i> Some vehicles may exhibit a sheet metal crack along the top inner ends of the tailgate. The bulletin describes the parts and the correct repair procedure.
23-45-96 8/2/96	'94-'96 (BR)	<i>Instrument panel creak.</i> This bulletin supersedes TSB 23-57-93, 8/8/93. A creak or squeak may be present on the left or right side of the instrument panel. The noise is caused by two sheet metal parts rubbing together. The repair involves loosening the instrument panel and providing additional clearance between the cowl and instrument panel support joint.
23-46-96 8/2/96	'94-'96 (BR)	<i>Rattle in door area.</i> Inspect the area of the door latch face around the lower window channel retaining bolt. If necessary perform the outlined repair procedure.
23-69-96 11/22/96	'97 (BR)	<i>Repair procedure for fallout/damaged paint.</i> Mopar Parts has released a new product, Mopar Fallout Removal Kit (p/n 04882417) for correcting paint damage due to industrial fallout, rail dust, over-spray and volcanic ash. The Mopar Fallout Removal Kit does not use a compounding process or acid wash and is the current Chrysler preferred method for correcting fallout damage. This product uses a clay polymer material and a liquid that are safer and better than other fallout removal methods.

CATEGORY 24**AIR CONDITIONING**

<u>TSB #</u>	<u>MODELS</u>	<u>SUBJECT/DESCRIPTION</u>
124-01-96A 10/18/96	'94-'96 (BR)	<i>Heater A/C system changes mode to defrost when accelerating.</i> This bulletin supersedes TSB 24-01-96 (2/2/96). The vacuum supply line to the Heater A/C system may drop when accelerating or when speed control engages. This may cause the vacuum motor to switch to defrost. The repair involves the addition of a vacuum check valve to the vacuum system.
24-12-96 8/2/96	'96 (BR) Vehicles assembled between 2/1/96 and 6/28/96 with a VIN code 3 as the first digit.	<i>Water leaks from HVAC floor outlet onto floor.</i> Water may drain out of the HVAC floor outlets while operating the A/C system. The bulletin describes the diagnosis and repair procedure.
24-16-96 10/11/96	'95-'96 (BR) With engine serial number 56230585 thru 56293178 or 45232867 thru 45360437. These engines were installed before 6/1/96.	<i>Vacuum system contaminated with engine oil.</i> Some Turbo Diesel trucks were produced without a check valve on the vacuum pump. Without a check valve oil may enter the vacuum system. A visual inspection of the HVAC system is presented and the repair procedure outlined.
02-03-97A 8/29/97	'94-'97 (BR)	<i>Rear of vehicle sits too low.</i> This bulletin supersedes TSB 02-03-97 as there were part number errors in the previous bulletin. The bulletin applies to 1500 series trucks rated at 6400 GVW and 2500 series trucks rated at 8800 GVW. The bulletin discusses rear leaf springs and shock absorber availability that will increase the height of the vehicle when the vehicle is at maximum GVW. The bulletin gives specific part numbers for various applications.

TECHNICAL SERVICE BULLETINS ISSUED DURING 1997

CATEGORY 5 BRAKES

<u>TSB #</u>	<u>MODELS</u>	<u>SUBJECT/DESCRIPTION</u>
02-03-97A 8/29/97	'94-'97 (BR)	<i>Chassis dynamics diagnosis.</i> The bulletin supersedes TSB 05-10-96 as revisions have been made to torque specifications and procedures. The bulletin summarizes different conditions that can cause a vehicle to move to the right or left when not controlled by the driver. A lengthy test procedure is outlined to isolate the cause of vehicle drift.
05-04-97 3/28/97	'94-'97 (BR) 2500-3500 series	<i>Accelerated brake lining wear, front versus rear.</i> This bulletin supersedes TSB 05-02-96A as the bulletin incorporates the use of revised brake linings for trucks with 80mm calipers (typically found on 2500, 4x2 trucks). The bulletin discusses wear conditions, repair procedures, part numbers and rear brake adjustment procedures.
05-07-97 9/22/97	'98 (BR)	<i>Parking brake release handle does not fully return.</i> The bulletin applies to trucks built prior to 8/15/97. If applicable, the repair procedure involves replacing a park brake release lever with a revised part.

CATEGORY 7 COOLING

<u>TSB #</u>	<u>MODELS</u>	<u>SUBJECT/DESCRIPTION</u>
07-03-97 5/9/97	All	<i>Engine coolant usage.</i> This information only bulletin discusses the use of propylene glycol instead of ethylene glycol coolants.

CATEGORY 8 ELECTRICAL

<u>TSB #</u>	<u>MODELS</u>	<u>SUBJECT/DESCRIPTION</u>
08-01-97 2/3/97	'96-'97 (BR)	<i>JTEC powertrain control wiring harness connector repair packages.</i> If a dealership determines that a powertrain customer complaint could be related to a poor electrical connection, the PCM connectors should be inspected. The bulletin describes an assortment of electrical connector and terminal repair components that are available to aid in powertrain electrical wiring repairs.
08-21-97 5/23/97	'94-'97 (BR)	<i>Engine failed to crank—no start.</i> This information only bulletin discusses a condition where the engine does not crank over when the ignition is placed in the start position. The shop should then refer to the appropriate '97 Service Manual for proper diagnosis of the starter motor's electrical circuit.
08-22-97A 7/11/97	'96-'97 (BR)	<i>Inoperative speed control.</i> This bulletin supersedes TSB 08-22-97, dated 6/20/97. The problem covered by the bulletin is an inoperative speed control due to a vacuum supply hose that is loose, leaking or deteriorated. Using the diagnosis as outlined in the '97 Service Manual determine the cause of the inoperative speed control. Perform the repair as outlined in the bulletin.
08-27-97A 9/26/97	'97 (BR)	<i>Inoperative CD player as a part of sales code RAZ radio.</i> This bulletin supersedes TSB 08-27-97, dated 7/18/97. The bulletin applies to '97 vehicles equipped with an AM/FM/cassette/CD player, sales code "RAZ" radio. A condition is described where the CD player may become inoperative, and will not accept the CD when attempting to insert the disk into the radio. The condition can be intermittent and may occur more often in hotter ambient temperatures. The AM/FM radio and cassette portion of the radio will continue to operate normally. The repair involves an exchange of the unit as supplied by Chryslers repair center.
08-30-97 9/5/97	'98 (BR)	<i>Ashtray receiver lamp degrades from blue-green to bright white.</i> The ash receiver lamp, when illuminated, may change from a blue-green illumination to a bright white illumination. This change will occur over a long period of time of continuous use. This bulletin involves replacing the ash receiver lamp and housing with revised parts.

CATEGORY 8 ELECTRICAL

<u>TSB #</u>	<u>MODELS</u>	<u>SUBJECT/DESCRIPTION</u>
08-30-97 9/5/97	'98 (BR)	<i>Ashtray receiver lamp degrades from blue-green to bright white.</i> The ash receiver lamp, when illuminated, may change from a blue-green illumination to a bright white illumination. This change will occur over a long period of time of continuous use. This bulletin involves replacing the ash receiver lamp and housing with revised parts.
08-32-97 9/19/97	'94-'98 (BR)	<i>NHTSA authorized airbag deactivation for medical necessity.</i> This information only bulletin describes the procedures necessary to deactivate airbags authorized by NHTSA. Airbag deactivation is a customer pay procedure, <u>not</u> covered under the provisions of warranty.
08-35-97 9/26/97	'98 (BR)	<i>Dead battery from ignition off draw (IOD).</i> The problem described is a dead battery due to the glove box lamp remaining illuminated when the glove box door is closed. The proper diagnosis involves performing an ignition-off draw (IOD) test as described in the '98 Service Manual. If necessary the bulletin outlines the installation of two spacers between the glove box lamp switch bracket and the instrument panel glove box opening upper reinforcement.
08-39-97 11/28/97	'98 (BR)	<i>Remote keyless entry transmitter batteries discharge prematurely.</i> This bulletin applies to vehicles built prior to August 15, '97 and describes a condition where the Remote Keyless Entry transmitter batteries discharge in approximately 6 weeks. The repair calls for replacement and reprogramming of the transmitter.

CATEGORY 11 EXHAUST

<u>TSB #</u>	<u>MODELS</u>	<u>SUBJECT/DESCRIPTION</u>
11-01-97 5/16/97	'94-'97 (BR)	<i>Whine or howl while driving at highway speeds.</i> This bulletin applies to vehicles equipped with the diesel engine option. Some vehicles may experience a whine or howl noise while driving at highway speeds. This noise may be miss-interpreted as turbo whine. After proper diagnosis of the condition the bulletin's repair procedure involves replacement of the muffler.

CATEGORY 14 FUEL

<u>TSB #</u>	<u>MODELS</u>	<u>SUBJECT/DESCRIPTION</u>
14-07-97 7/18/97	'94-'97 (BR)	<i>Diesel fuel injection pump tampering.</i> This information only bulletin applies to inline fuel injection pumps as found on '94 thru early '98 model trucks. The bulletin stipulates that there are only a few items on the pump that are serviceable (low idle adjustment, timing adjustment, throttle linkage adjustment, and air bleed procedures). Any other adjustments or modifications are considered tampering. Tampered injection pumps are not warrantable. The bulletin shows the service location where to look for suspected tampering.

CATEGORY 18**VEHICLE PERFORMANCE**

<u>TSB #</u>	<u>MODELS</u>	<u>SUBJECT/DESCRIPTION</u>
18-25-97 8/15/97	'96-'97 (BR)	<i>EGR system failure with Hex Code \$2E* on 5.9L Diesel.</i> This bulletin applies to vehicles equipped with a 5.9L Cummins Diesel engine built between Jan. 1, 1996 and Dec. 31, 1996 with California emissions sales code NAE. If while performing other diagnostics, the technician notices Hex Code \$2E - EGR SYSTEM FAILURE on the Diagnostic Scan Tool (DRB III) the diagnosis outlined in the bulletin should be followed. The customer may or may not experience any engine driveability symptoms. The Malfunction Indicator Lamp (MIL) will not be illuminated. The repair involves using revised test procedures to diagnose the EGR system and selectively erase and reprogram the Powertrain Control Module (PCM) with new software (calibration changes) for the condition listed. <i>*Editor's note: \$2E is correct.</i>
18-29-97A 12/5/97	'96-'98 (BR) with Cummins engine and five-speed transmission	<i>Vehicle bucking on '96 thru '98 trucks with the Cummins engine and a manual transmission.</i> This bulletin supersedes TSB 18-29-97, dated 10/17/97. The condition to be corrected is one where the vehicle may exhibit a bucking or jerking condition while under light acceleration or while driving at steady state speeds. The vehicle may be in a loaded or unloaded state when the bucking or jerking occurs. This condition results from the sensitivity of the throttle linkage to driver input. The repair procedure involves replacement of the throttle linkage levers with revised parts.

CATEGORY 19**STEERING**

<u>TSB #</u>	<u>MODELS</u>	<u>SUBJECT/DESCRIPTION</u>
19-08-97 5/30/97	'96-'97 (BR)	<i>Clunk/rattle felt in steering column/wheel.</i> This bulletin supersedes TSB 19-01-96, dated 2/9/96 for 1996 model year vehicles. This bulletin applies to all vehicles built in the United States (first digit of VIN = 1) and vehicles built in Mexico (first digit of VIN = 3) before Mar. 3, 1997. The condition to be examined is a clunk or rattle that maybe felt in the steering wheel/column during slow turns, rough road driving, and stops. The diagnosis involves inspection of the front suspension and steering components, including a check of all fasteners for proper torque as specified in the appropriate Service Manual. The repair procedure involves replacement of the steering intermediate shaft.
19-10-97 8/15/97	'94-'98 (BR)	<i>Steering wander.</i> If when driving on a straight road, a higher than normal steering wheel movement (perceived as excessive play) is required to keep the vehicle going straight or if over-compensating the steering to keep the vehicle from wandering is a condition, the bulletin describes the diagnosis and repair procedure. The repair involves adjustment of the over-center and, if necessary, the worm thrust bearing preload adjustments on the steering gear.
19-16-97 11/28/97	'94-'97 (BR)	<i>Lower steering column noise and/or minor lower steering column movement.</i> This bulletin applies to vehicles built before Dec. 31, 1996 and describes a lower steering column noise and/or minor lower steering column movement. If movement in the steering column is greater than the tolerance, the repair involves adding a "toe plate" (shim) to the steering column.

CATEGORY 21**TRANSMISSION**

<u>TSB #</u>	<u>MODELS</u>	<u>SUBJECT/DESCRIPTION</u>
21-12-97 8/29/97	'96-'97 (BR)	<i>Transfer case shifter buzz or rattle.</i> This bulletin supersedes TSB 21-13-96, dated 9/20/96. A buzz or clatter may be heard from the 4x4 transfer case shifter at an engine speed of approximately 2000 rpm. The condition may worsen when the engine is under load. On vehicles equipped with automatic transmission the diagnosis must be done with the transmission in overdrive and torque converter clutch engaged. If necessary the correction involves bending the shift lever spring reaction tab outward to increase the spring tension on the shift lever.

CATEGORY 22**WHEELS & TIRES**

<u>TSB #</u>	<u>MODELS</u>	<u>SUBJECT/DESCRIPTION</u>
22-01-97 6/13/97	'96-'97 (BR)	<i>Tire and wheel runout.</i> Radial runout is the vertical distance between the high and low points on the tire or wheel edge measured at the center line of the tread. Lateral runout is the horizontal movement of the tire or wheel measured near the shoulder of the tire. Runout of more than the preferred specification may cause the vehicle to shake. This information only bulletin provides the proper specification for runout.

CATEGORY 23**BODY**

TSB #	MODELS	SUBJECT/DESCRIPTION
23-03-97 2/14/97	'89-'93 (AD) '94-'97 (BR)	<i>Difficult to clean light colored "chalky" residue from black plastic body components.</i> The discussion covers difficult to clean light colored "chalky" residue from exterior plastic body components that are molded in black, especially those that are textured, such as door handles, mirrors, roof rack attachments, etc. Frequently, this "chalky" residue is actually an accumulation of car wax, road grime, etc. trapped in the plastic grain. The correction is to clean the component with a soft bristle brush and mild detergent (liquid dish soap) until the residue is gone.
23-22-97 4/4/97	'94-'97 (BR)	<i>Driver's side wiper blade contacts A-Pillar.</i> This bulletin applies to vehicles built before Oct. 15, 1996. If the driver's side wiper blade contacts A-Pillar or a popping sound can be heard when the driver's side wiper blade reaches its full upper wipe position (farthest to the left) during high speed wiper operation, this bulletin describes the repair procedure. The repair has the dealership replace the wiper blades with a blade that has a revised air deflector.
23-25-97 5/2/97	'96-'97 (BR)	<i>Windnoise (whistle) around grille area.</i> This bulletin supersedes TSB 23-27-96, dated 4/19/96. Vehicles may exhibit a condition where a windnoise whistle occurs from the front of the vehicle. This condition can occur while driving the vehicle at highway speeds between 45-65 mph or at slower speeds when driving into a headwind. If necessary a foam strip is installed between the grille and hood.
23-27-97 5/9/97	'94-'97 (BR)	<i>Water leaking through rear window.</i> The problem is water leaking past rear window module into cab of vehicle. The bulletin outlines the repair procedure.
23-39-97 6/27/97	'94-'97 (BR)	<i>Driver side power mirror vibrates while driving.</i> This bulletin supersedes TSB 08-64-94, dated 11/4/94. The condition covered in the bulletin is one where the driver side power mirror vibrates causing blurred images in driver side mirror while driving. The repair involves installing a power mirror support bracket onto the driver's side mirror.
23-61-97 11/28/97	'94-'98 (BR)	<i>Noise coming from cargo box area.</i> The problem is an "oil canning" noise complaint coming from the box area caused by the cargo box cross member contacting the vehicle's frame as the vehicle is operated over a rough-surfaced road. The repair involves installing isolators on two cargo box cross member rails.
23-67-97 12/6/97	'98 (BR)	<i>Upper rear corner of front door contacts upper front corner of cargo door.</i> This bulletin applies to Quad Cab Ram trucks and describes a door closing condition where the upper rear corner of the front door may come in contact with the upper front corner of the cargo door, causing the paint to chip off the front and/or cargo door. If such, the correction is the installation of an anti chip plastic molding over the chipped area.
23-68-97 12/19/97	'98 (BR)	<i>Water leaking into vehicle through side cowl panel.</i> This bulletin applies to vehicles built between November 16, 1997 and November 26, 1997. If water leaks through either the right and/or left side cowl panels and dampens the carpet in the foot well area, a trim cover is removed and a water proof patch is installed over the cowl panel.

CATEGORY 24**AIR CONDITIONING**

TSB #	MODELS	SUBJECT/DESCRIPTION
24-11-97 7/11/97	'94-'98 (BR)	<i>A/C evaporator odor.</i> This bulletin supersedes technical service bulletin 24-06-95A, dated 5/26/95. Some vehicle operators may experience a musty odor from the A/C system, primarily at start up in hot and humid climates. This odor may be the result of microbial growth on the evaporator core. During normal A/C system operation, condensation forms in and around the A/C evaporator. When airborne pollutants mix with this condensation, bacteria and fungi growth begins and odor results. The repair involves cleaning the evaporator with Mopar aerosol cleaner.

TECHNICAL SERVICE BULLETINS ISSUED DURING 1998

CATEGORY 25

BRAKES

<u>TSB #</u>	<u>MODELS</u>	<u>SUBJECT/DESCRIPTION</u>
05-04-98 6/12/98	'97-'99 (BR)	<i>Height sensing proportioning valve removal.</i> This procedure should only be performed on 2500 series 4x4 vehicles that are continuously operated at 75% or greater GVW and have had their rear suspension altered. The bulletin describes a procedure the dealer should follow in the removal of a rear height sensing proportioning valve. Removal of the proportioning valve should help prolong front brake life.

CATEGORY 6

CLUTCH

<u>TSB #</u>	<u>MODELS</u>	<u>SUBJECT/DESCRIPTION</u>
06-01-98 6/19/98	'97-'98 (BR)	<i>Release fork orientation.</i> This bulletin applies to vehicles equipped with an NV4500 manual transmission and either the 8.0L gas engine or the 5.9L Cummins diesel engine. The bulletin covers the proper installation of the clutch release fork.

CATEGORY 7

COOLING

<u>TSB #</u>	<u>MODELS</u>	<u>SUBJECT/DESCRIPTION</u>
07-08-98 12/11/98	'98-'99 (BR)	<i>Diesel engine overheating.</i> This information applies to vehicles equipped with a 24 valve Cummins diesel engine with an engine serial number (ESN) 56512007 or prior. This bulletin involves replacing the thermostat with a revised part (05015090AA).

CATEGORY 8

ELECTRICAL

<u>TSB #</u>	<u>MODELS</u>	<u>SUBJECT/DESCRIPTION</u>
08-09-98 3/13/98	'94-'98 (BR)	<i>Driver side power mirror vibrates while driving.</i> This bulletin supersedes technical service bulletin 23-39-97, dated June 27, 1997. The problem covered is that the driver side power mirror vibrates or causes blurred images in driver side mirror while driving. If removal of aftermarket bugscreen deflectors does not cure the problem, a procedure for installing a mirror reinforcement bracket is described.
08-11-98 3/13/98	'98 (BR)	<i>Delayed operation of fog lamps.</i> The fog lamps illuminate approximately two seconds after being turned ON with the headlamp LOW beams illuminated. This condition may also occur when the headlamps are turned from HIGH beam to LOW beam with the fog lamps ON. The repair involves checking the headlamp connector for proper wire location.
08-13-98 3/27/98	'98 (BR)	<i>Headlamp switch knob pulls out of headlamp switch.</i> This bulletin applies to vehicles built before November 16, 1997. Rotate the headlamp switch knob to the full dim position. Then, apply pressure to the side of the knob and pull the knob to turn the headlamps ON. If the knob pulls out of the headlamp switch when the headlamps are turned ON, replace the knob using the described repair procedure.

CATEGORY 8**ELECTRICAL**

TSB #	MODELS	SUBJECT/DESCRIPTION
08-14-98 3/27/98	'98 (BR)	<p><i>Clicking, rattling, or ratcheting noise coming from the seat belt retractor.</i></p> <p>This bulletin applies to all club cab vehicles (both two door Club Cab and Quad Cab models) built before March, 5, 1998. During normal operation, the seat belt retractor on the vehicles listed above may emit a clicking, rattling, or ratcheting noise. This noise may be caused by a solenoid that is energized and de-energized to operate the retractor spool of the seat belt retractor assembly. The solenoid is controlled by a Seatbelt Control Timer Module (SCTM) which unlocks the retractor when energized.</p> <p>If your diagnosis determines and the owner feels that the noise occurs too frequently, the SCTM on your vehicle may be too sensitive and should be replaced.</p>
08-16-98 4/17/98	'89-'93 (AD) '94-'99 (BR)	<p><i>Installation of radio transmitting equipment.</i></p> <p>This bulletin supersedes technical service bulletin 08-22-95, dated May 12, 1995. This information-only TSB is provided to assist in properly installing communication equipment in Chrysler vehicle. This information should be given to any owner inquiring about installing radio transmitting equipment.</p>
08-17-98 Rev. C 12/30/98	'94-'99 (BR)	<p><i>Airbag on-off switches.</i></p> <p>This bulletin supersedes technical service bulletin 08-17-98 Rev. B dated September 18, 1998. This information only bulletin is provided to identify the parts and procedures necessary to deactivate airbags authorized by NHTSA. Airbag deactivation is a customer pay procedure.</p>
08-21-98 5/22/98	'98 (BR)	<p><i>Radio Interference to/from two-way radio receivers.</i></p> <p>Customers may complain of intermittent poor reception on their two-way radios. This condition does not affect the operation of any AM or FM band radio. Radio receivers from approximately 20 MHZ to 174 MHZ may be susceptible to Radio Frequency Interference (RFI) from the fuel pump module's motor. If there is RFI, the bulletin describes the installation of an RFI filter in series with the electric fuel pump.</p>
08-35-98 6/24/98	'98 (BR)	<p><i>Instrument cluster bezel breaks when removed.</i></p> <p>This information-only bulletin is a reminder that the instrument cluster bezel is retained by several snap clip retainers and <u>one</u> screw located underneath the power outlet access door. It is imperative that this singular screw is removed prior to attempting to remove the instrument cluster bezel from the instrument cluster.</p>
08-36-98 6/24/98	'89-'93 (AD) '94-'99 (BR)	<p><i>Use of two digit calendar year codes in automotive computers.</i></p> <p>There has been a great deal of recent media attention regarding the turn of the century (year 2000, Y2K, etc.) and the effect it will have on computers that have used two-digit calendar year coding in their programming. Questions are arising regarding computers used in automotive applications and the effect year 2000 will have on them.</p> <p>Two digit calendar-year codes have not been used in any Chrysler automotive onboard applications and no problems related to use of two digit coding for calendar years are anticipated.</p>
08-51-98 11/27/98	'99 (BR)	<p><i>Compass mini trip computer indicates erroneous average miles per gallon, distance to empty, and/or trip odometer.</i></p> <p>This bulletin applies to vehicles equipped with the compass mini trip computer (sales code CUS). The display will show an erroneous number in the third digit from the right. If repair is necessary, the module is replaced.</p>
08-54-98 12/30/98	'99 (BR)	<p><i>Static inside speakers and/or side speaker cuts out when power outside mirror operates.</i></p> <p>This bulletin applies to vehicles equipped with the power audio amplifier (sales code RDE) and heated outside power mirrors (sales code GTS) built between September 7, 1998 and November 3, 1998. The problem discussed is that static can be heard in the side speakers and/or the sound coming from the side speakers can cut out and/or in extreme cases, the radio can cut out with the radio in the FM mode when the power mirror is actuated to its end of travel. The repair involves replacing the mirrors.</p>

CATEGORY 9**ENGINE**

<u>TSB #</u>	<u>MODELS</u>	<u>SUBJECT/DESCRIPTION</u>
08-14-98 3/27/98	'98 (BR)	<i>Clicking, rattling, or ratcheting noise coming from the seat belt retractor.</i> This bulletin applies to all club cab vehicles (both two door Club Cab and Quad Cab models) built before March, 5, 1998. During normal operation, the seat belt retractor on the vehicles listed above may emit a clicking, rattling, or ratcheting noise. This noise may be caused by a solenoid that is energized and de-energized to operate the retractor spool of the seat belt retractor assembly. The solenoid is controlled by a Seatbelt Control Timer Module (SCTM) which unlocks the retractor when energized. If your diagnosis determines and the owner feels that the noise occurs too frequently, the SCTM on your vehicle may be too sensitive and should be replaced.

CATEGORY 11**EXHAUST**

<u>TSB #</u>	<u>MODELS</u>	<u>SUBJECT/DESCRIPTION</u>
11-08-98 9/25/98	'94-'98 (BR)	<i>Turbo Diesel wastegate actuator repair kit.</i> A new kit has been released that will allow technicians to repair turbochargers with failed wastegate actuators.

CATEGORY 14**FUEL**

<u>TSB #</u>	<u>MODELS</u>	<u>SUBJECT/DESCRIPTION</u>
14-01-98 Rev. A 7/17/98	'98 (BR)	<i>High pressure fuel line service.</i> This bulletin supersedes technical service bulletin 14-01-98 dated March 6, 1998. This information applies to the 5.9L Cummins electronically injected 24 valve diesel built prior to engine serial number (ESN) 56462592. Design revisions have been made to the injector connector tube, and the new design can be re-torqued multiple times without compromising the seal between the connector tube and high pressure fuel line. The new part number for this connector tube is 05013856AA/Cummins 3944833.
14-02-98 3/27/98	'98 (BR)	<i>Fuel filter requirements.</i> With the introduction of the Cummins 24 valve electronically injected engine, a new VP44 injection pump was also introduced. The VP44 injection pump requires finer fuel filtration due to tighter tolerances within the pump. Whenever a fuel filter is replaced, make sure the replacement filter is part number 04883963AB/Cummins 3931476/Fleetguard FS19528.
14-04-98 5/8/98	'99 (BR)	<i>Accelerator pedal buzzing noise with cruise control engaged.</i> This bulletin applies to vehicles equipped with the 5.9L 24 valve Cummins diesel engine. If an audible buzz is coming from the accelerator pedal when the cruise control is engaged a road test diagnosis is described. If necessary, a re-routing of the accelerator cable is described.

CATEGORY 18**VEHICLE PERFORMANCE**

<u>TSB #</u>	<u>MODELS</u>	<u>SUBJECT/DESCRIPTION</u>
18-06-98 2/27/98	'94-'98 (BR)	<i>Effects of incorrect idle speed.</i> This information applies to the 5.9L Cummins mechanically injected 12 valve diesel. Incorrect idle adjustments (either too high or low) may cause many different customer concerns. The bulletin gives a list of items that explain the condition/symptoms associated with incorrect idle settings along with component checks and specifications to set it properly.
18-07-98 2/27/98	'94-'98 (BR)	<i>Effects of incorrect idle speed.</i> This information applies to the 5.9L Cummins mechanically injected 12 valve diesel. Incorrect idle adjustments (either too high or low) may cause many different customer concerns. The bulletin gives a list of items that explain the condition/symptoms associated with incorrect idle settings along with component checks and specifications to set it properly.

CATEGORY 21 TRANSMISSION

<u>TSB #</u>	<u>MODELS</u>	<u>SUBJECT/DESCRIPTION</u>
21-10-98 Rev. A 9/25/98	'94-'99 (BR)	<p><i>Loss of fifth gear.</i></p> <p>This bulletin supersedes technical service bulletin 21-10-98, with an effective date of September 11, 1998. This bulletin applies to vehicles equipped with a NV4500 manual transmission and the 8.0L V10 gas engine or the 5.9L Cummins diesel engine. The problem described is that the transmission operates normally through all ranges except fifth gear. The 14 page bulletin describes the proper repair procedure.</p>

CATEGORY 23 BODY

<u>TSB #</u>	<u>MODELS</u>	<u>SUBJECT/DESCRIPTION</u>
23-13-98 5/8/98	'98 (BR)	<p><i>Rear sliding window difficult to open, will not remain latched, and/or leaks water past the lower run channel.</i></p> <p>If the rear sliding window is difficult to open, will not latch, and/or leaks water past the sliding rear window's lower run channel, this bulletin describes the proper diagnosis/repair.</p>
23-16-98 5/1/98	'98 (BR)	<p><i>Splash guards (mud flaps) discolored and/or distorted due to proximity to tailpipe.</i></p> <p>This bulletin applies to vehicles equipped with dual rear wheels. Vehicles equipped with splash guards may experience discoloration and/or distortion along the outside edge of the passenger side rear splash guard due to the proximity to the tailpipe. If necessary, a new tailpipe assembly is installed.</p>
23-17-98 5/1/98	'94-'98 (BR)	<p><i>Center armrest driver side hinge cover broken.</i></p> <p>If the center armrest upper inertia latch cover (driver side hinge cover) is broken, the proper repair involves replacement of the hinge.</p>
23-35-98 8/7/98	'94-'99 (BR)	<p><i>Door trim panel retainer clip attachment breakage when door trim panel is removed for service.</i></p> <p>The bulletin cautions the dealer that damage to the door trim panel may occur if the door trim panel retainer clips are separated from the door without using a trim panel removing tool.</p>
08-54-98 12/30/98	'99 (BR)	<p><i>Cargo net eliminated from production.</i></p> <p>This bulletin applies to standard cab vehicles and informs the dealer network that the cargo net is no longer a production item. It can be purchased through the parts department using Mopar number 04761197.</p>
23-58-98 11/27/98	'99 (BR)	<p><i>Wind noise (whistle) around grill area and/or dimples on the grill painted surface opposite of the grill fasteners.</i></p> <p>This bulletin applies to Ram trucks equipped with the sport package. If there is a windnoise whistle occurring from the front of the vehicle at highway speeds between 45-65 mph or at slower speeds when driving into a headwind, this bulletin describes the repair procedure.</p>

TECHNICAL SERVICE BULLETINS ISSUED DURING 1999

CATEGORY 2 FRONT SUSPENSION

<u>TSB #</u>	<u>MODELS</u>	<u>SUBJECT/DESCRIPTION</u>
02-06-99 Rev. A 12/17/99	'94-'00 (BR)	<p><i>Front wheel bearing grease is evident on the bearing seal area.</i></p> <p>This bulletin supersedes TSB 02-06-99, dated June 11, 1999. The revisions include the addition of 4x2 models and additional model years. This information-only bulletin discusses the fact that front wheel bearings may be incorrectly diagnosed as faulty due to the evidence of wheel bearing grease on the bearing seal areas. This grease purge is a normal design condition. The factory fill of the bearings includes a slightly greater amount of grease than is required for the bearing lifetime lubricant. A portion of the grease purges through the self-venting seal in the initial few thousand miles to form an additional barrier in the area of the seal and the stamped slinger. This barrier aids in the prevention of contaminants passing through the seal and into the bearing. Do not remove or clean the purged grease as part of normal maintenance because it provides additional protection and once removed, damage to the seal and bearing could result.</p>
02-13-99 09/10/99	'94-'99 (BR)	<p><i>Squeaking noise from rear leaf springs.</i></p> <p>This bulletin supersedes TSB 02-03-96, dated may 31, 1996. If the diagnosed condition is a squeaking noise coming from the rear of the vehicle, the bulletin gives the correct repair procedure to replace the leaf spring tip liners/install spring clip isolators.</p>

CATEGORY 5 BRAKES

<u>TSB #</u>	<u>MODELS</u>	<u>SUBJECT/DESCRIPTION</u>
05-04-99 05/28/99	'98-'99 (BR)	<p><i>Chassis dynamics diagnosis.</i></p> <p>This 21-page bulletin involves diagnosis and repair of a vehicle drift condition and on some vehicles, installing a shim between the wheel and the brake rotor, between the wheel and hub/bearing assembly, or between the wheel and hub extension.</p> <p>Chassis dynamics diagnosis is the diagnosis of a condition where the vehicle may move either to the right or the left when not controlled by the driver. This condition can be caused by any of the following: Non-factory installed options (e.g. snow plow), tires or wheels of different size, aftermarket wheels, tires that have a belt that has shifted, incorrect tire pressure, a vehicle that is carrying extra added weight (e.g. tool boxes), steering and/or suspension components that are worn or damaged, wheel bearings that are worn or damaged, a vehicle that is not with in alignment specifications, brake drag from brake components that do not release, or braking imbalance.</p> <p>Additionally, under certain road conditions (e.g. high road crown, grooved roads, etc.), most vehicles will move to the right or left uncontrolled by the driver. Also, the same may happen if a cross-wind condition exists.</p>
05-11-99 12/31/99	'94-'96 (BR)	<p><i>Revised power brake booster check valve.</i></p> <p>This bulletin applies to vehicles equipped with the 5.9L Cummins diesel engine. A revised power brake booster check valve p/n 05011393AA has been released for service. The new check valve performance has been improved by changing the flapper style check valve to a spring loaded style check valve. The spring loaded style check valve performance is superior, especially in vehicles that utilize mechanical vacuum pumps to provide the vacuum source to operate the power brake booster. Part number 05011393AA should be used any time the power brake booster check valve is serviced on the subject model vehicles.</p>

CATEGORY 8**ELECTRICAL**

<u>TSB #</u>	<u>MODELS</u>	<u>SUBJECT/DESCRIPTION</u>
08-06-99 Rev. A 12/17/99	'98-'00 (BR)	<p><i>Radio interference to/from two-way radio receivers.</i></p> <p>This bulletin supersedes technical service bulletin 08-06-99, dated March 5, 1999. Customers may complain of intermittent poor reception on their two-way radios. This bulletin involves installing a RFI filter in series with the electric fuel pump motor.</p>
08-16-99 6/11/99	'99 (BR/BE)	<p><i>Inoperative or intermittent remote keyless entry (RKE) transmitter.</i></p> <p>This bulletin supersedes TSB 08-16-99, Dated May 28, 1999. This bulletin applies to vehicles built prior to March 1, 1999. It applies only to vehicles equipped with the new peanut shaped transmitters. The problem discussed is an inoperative RKE transmitter. This condition may be intermittent and will have similar symptoms to a dead transmitter battery. This can be caused by a lost or intermittent contact between the battery terminal and the printed circuit board. A transmitter repair kit containing a new case with an improved battery terminal has been released. This bulletin involves replacing the RKE transmitter case.</p>
08-17-99 05/28/99	'99 (BR)	<p><i>Compass/mini-trip computers no longer need calibration during new vehicle preparation.</i></p> <p>This information-only bulletin applies to vehicles equipped with the compass/mini-trip computer (sales code CUS) built after April 28, 1999. Vehicles equipped with the compass/mini-trip computer are now having their compasses calibrated by the assembly plant making it no longer necessary to calibrate the compass during new vehicle preparation. However, in order to ensure proper operation of the compass, it will still be necessary to set the variance of the compass prior to vehicle retail delivery.</p>
08-22-99 07/02/99	'98 (BR)	<p><i>Intermittent operation of oil pressure gauge.</i></p> <p>This bulletin applies to vehicles equipped with the 5.9L Cummins 12-valve Turbo Diesel engine built before January 5, 1998. The condition for correction is an oil pressure gauge that intermittently drops to zero pressure. In addition, the warning chime may sound when the oil pressure gauge drops to zero pressure and the check gauge lamp may come on. Proper repair involves selectively erasing and reprogramming the Powertrain Control Module (PCM) with new software (a calibration change).</p>
08-28-99 08/20/99	'00 (BR)	<p><i>Simplified compass mini trip computer calibration.</i></p> <p>This bulletin applies to vehicles equipped with the compass mini trip computer (sales code CUS). The subject model vehicles are shipped from the assembly plants with the compass mini trip computer NOT calibrated. This will be identified by "CAL" displayed on the compass mini trip computer. To calibrate the compass mini trip computer, drive the vehicle in a complete circle until "CAL" is no longer displayed on the compass mini trip computer.</p>
08-32-99 10/01/99	'98-'99 (BR)	<p><i>Radio interference to/from two-way radio receivers.</i></p> <p>This bulletin addresses the complaint of intermittent poor reception on two-way radios, and discusses the proper repair. Radio receivers from approximately 30 MHZ to 50 MHZ may be susceptible to Radio Frequency Interference (RFI) from the Airbag Control Module (ACM).</p> <p>Note: Technical service bulletin 08-06-99, dated March 5, 1999, addresses two-way radio interference from the fuel pump module and should be performed prior to performing this technical service bulletin.</p>
08-37-99 11/12/99	'94-'00 (BR)	<p><i>Airbag On-Off Switches.</i></p> <p>This bulletin supersedes technical service bulletin 08-17-98 Rev C, dated December 30, 1998. This information-only bulletin identifies the parts and procedures necessary to deactivate airbags authorized by NHTSA. Airbag deactivation is a customer pay procedure, NOT covered under the provisions of the warranty.</p>
08-39-99 12/10/99	'00 (BR)	<p><i>Communications may stop between the JTEC PCM and a generic scan tool.</i></p> <p>This information applies to vehicles built before November 30, 1999. The JTEC Powertrain Control Module (PCM) may stop communications with a generic scan tool. This bulletin involves selectively erasing and reprogramming the JTEC PCM with new software calibration change (00Cal13 & 00Cal13A).</p>

CATEGORY 8 ELECTRICAL

<u>TSB #</u>	<u>MODELS</u>	<u>SUBJECT/DESCRIPTION</u>
08-42-99 12/17/99	'98-'99 (BR)	<p><i>The fuel gauge reads full for an excessive period of time.</i></p> <p>This bulletin applies to vehicles equipped with the 5.9L Cummins diesel engine. After driving over 200 miles, the fuel gauge may read full until the vehicle travels over a bump in the road and then the gauge operates normally. This condition may be caused by the float in the fuel pump module sticking and may be difficult to diagnose. Perform the repair procedure (new fuel pump module) if the customer's concern matches the description identified in the Symptom/Condition.</p>
08-43-99 12/17/99	'98-'99 (BR)	<p><i>Central timer module software update when a wiper module is replaced.</i></p> <p>This bulletin applies to vehicles equipped with remote keyless entry. Due to a design change in MOPAR replacement wiper modules, the central timing module must be updated with new software in order to allow the wiper module to function properly. The outlined repair procedure must be performed any time the wiper module is replaced.</p>
08-44-99 12/31/99	'98-'00 (BR)	<p><i>Intermittent speaker operation/static.</i></p> <p>This bulletin applies to vehicles equipped with the Infinity sound system sales codes (RBR, RBN, and RAZ) built before October 1, 1999. The condition is intermittent operation/static that may occur in any or all speakers. The bulletin describes the proper repair.</p>

CATEGORY 9 ENGINE

<u>TSB #</u>	<u>MODELS</u>	<u>SUBJECT/DESCRIPTION</u>
09-04-99 07/16/99	'98-'99 (BR)	<p><i>Hard-to-diagnose noise coming from the engine turbocharger area.</i></p> <p>This bulletin applies to vehicles equipped with a Cummins 5.9L – 24V diesel engine built prior to engine serial number (ESN) 56587424. The ESN is located on the engine data plate which is located on the front left side of the engine, affixed to the gear housing.</p> <p>A noise may be present which on initial investigation may sound like a noisy turbocharger bearing. The sound of the noise may be described as a whistle, a squeal, a howl, a moan, or a gurgle. The noise will be more noticeable as engine temperature increases. The noise will most often occur when the warm engine is operated between 1,500 and 2,200 rpm's. The noise is usually heard in the cab, louder on the passenger side or seems to come from the dash vents. The noise may be caused by the coolant supply hose connector. The connector is located on the cylinder head next to the turbocharger. The connector is used to supply coolant to the heater hose. The bulletin describes the replacement of the hose connector.</p>

CATEGORY 18 VEHICLE PERFORMANCE

<u>TSB #</u>	<u>MODELS</u>	<u>SUBJECT/DESCRIPTION</u>
18-02-99 02/19/99	'98-'99 (BR)	<p><i>Erratic torque converter clutch (TCC) operation.</i></p> <p>This information applies to vehicles equipped with a 5.9L 24-valve diesel engine and automatic transmission built between January 1, 1998 and December 18, 1998. Some vehicles may exhibit a surge-like condition while in fourth gear. This may be caused by the TTC unlocking and locking when it should be consistently locked. The cause of this erratic operation has been identified as electrical noise from the Throttle Position Sensor (TPS) or Alternator. This bulletin involves selectively erasing and reprogramming the Powertrain Control Module (PCM) with new software (calibration changes 98cal12 and 99cal14).</p>
18-07-99 04/30/99	'98-'99 (BR)	<p><i>Erroneous MIL illumination with DTC \$A8 (P1763) governor pressure sensor volts too high.</i></p> <p>This information applies to vehicles equipped with a reseries automatic transmission built before December 18, 1998. Some vehicles may exhibit a MIL illumination with DTC \$A8 (P1763) - GOVERNOR PRESSURE SENSOR VOLTS TOO HIGH. The vehicle operator may experience slower than normal accelerations because the transmission may temporarily enter third gear "Limp-In" Mode. The "Limp-In" Mode may last until the vehicle owner cycles the ignition key. The technician may not detect a problem with the automatic transmission during a diagnostic test or test drive. The MIL is caused by an increase in hydraulic pressure. The increased hydraulic pressure is the result of a new valve body machining process. Vehicles built after January 1, 1998 have an automatic transmission with this new process valve body. Vehicles built before January 1, 1998 may experience this condition if either the transmission valve body or the entire automatic transmission was replaced with components manufactured after January 1, 1998. This bulletin involves selectively erasing and reprogramming the JTEC Powertrain Control Module (PCM) with new software (calibration changes 99Cal14, 98Cal12).</p>

CATEGORY 18**VEHICLE PERFORMANCE**

TSB #	MODELS	SUBJECT/DESCRIPTION
18-08-99 04/30/99	'98-'99 (BR)	<p><i>Improved speed control system sensitivity to set speed.</i></p> <p>Some customers may complain that their vehicle speed control system may be too busy or drift more than 2 mph below or above the initial vehicle set speed. Vehicle load and road/terrain conditions may impact this issue. The new PCM software improves the speed control system sensitivity so that the vehicle speed remains closer to its set speed with fewer engine rpm oscillations. This bulletin involves selectively erasing and reprogramming the JTEC Powertrain Control Module (PCM) with new software (calibration changes 98Cal12A, 99Cal 17). There is no change to the Cummins CM551 Engine Control Module (ECM) software.</p>
18-09-99 05/21/99	'99 (BR)	<p><i>Common diagnostic trouble codes caused by an open fuse.</i></p> <p>Analysis has revealed an issue with repeated repairs for the same Diagnostic Trouble Code (DTC). The DTC may be due to an overlooked open circuit used to power the component in question. In most instances, either the circuit fuse has been erroneously removed or the fuse itself is open (blown). The component in question, and its circuit, are often protected by two fuses. It is usually the lower amperage fuse that is either missing or open. The lower amperage fuse is positioned electrically in the circuit between the component in question and either a relay or the ignition switch. The lower amperage fuse will be located either in the underhood Power Distribution Center (PDC) or in the instrument panel Junction Block. The lower amperage fuse is often missing because it was removed erroneously for use in another low current circuit. If the lower amperage fuse is open (blown), then the circuit and component in question must be checked for an electrical short. Check to make sure that the open fuse was not exchanged with another fuse or was damaged by an installed accessory.</p>
18-11-99 05/28/99	'98-'99 (BR)	<p><i>Slow acceleration or lack of power while towing or hauling a heavy load.</i></p> <p>This information applies to vehicles equipped with a 5.9L - 24V diesel engine built before engine serial number 56587297 with a date of engine manufacture of May 5, 1999. This information is available on the engine data plate, which is located on the left side of the engine, affixed to the gear housing. There may be a condition of low power or slow acceleration when towing or when hauling a heavy load. This software change, to the Cummins CM551 diesel engine controller, will increase engine torque. Some 1998 BR vehicles equipped with a 5.9L - 24V diesel engine may already have the latest software revision. Verify that the ECM is at calibration level 98T17 (p/n's 333034303J / 333035303J / 333036303J / 333037303J). If the calibration level is 98T17, then this TSB does not apply and further powertrain diagnosis may be required. This bulletin involves selectively erasing and reprogramming the Cummins CM551 Engine Control Module (ECM) with new software (calibration changes 98Cal T17 and 99CalT8B). There is no change to the JTEC PCM software.</p>
18-21-99	'98-'99 (BR)	<p><i>5.9L - 24V Cummins diesel low power or poor performance diagnostic.</i></p> <p>The vehicle operator may complain of slow acceleration or a lack of power when towing or hauling moderate to heavy loads. The condition may be worse at higher altitude. Do not proceed with this technical service bulletin until TSB 18-11-99 has been performed. This bulletin further describes diagnostic procedures that may be used to assist the technician in the diagnosis of a low power or poor performance complaint.</p>
18-24-99 11/15/99	'00 (BR)	<p><i>5.9L - 24V Cummins diesel low power or poor performance diagnostic.</i></p> <p>The vehicle operator may complain of slow acceleration or a lack of power when towing or hauling moderate to heavy loads. The condition may be worse at higher altitude. This bulletin involves diagnostic procedures that may be used to assist the technician in the diagnosis of a low power or poor performance complaint. The procedures outlined start with confirmation that TSB 18-11-98 (turbocharger wastegate actuator repair kit) has been performed. Additionally, the technician should verify that the throttle is opening fully.</p> <ul style="list-style-type: none">• Perform the complete FUEL TRANSFER PUMP PRESSURE TEST procedure.• Inspect the fuel tank rollover valve for restrictions and to ensure that the shipping cap has not been left on the end of the valve.• Inspect the charge air cooler hoses and clamps for proper installation. Inspect all connections and clamps for looseness. Verify that no leaks are present when the engine is under boost conditions.• While performing the following road test, verify that the turbo boost pressure is 16 psi during wide open throttle (WOT) acceleration.

CATEGORY 18**VEHICLE PERFORMANCE**

<u>TSB #</u>	<u>MODELS</u>	<u>SUBJECT/DESCRIPTION</u>
18-24-99 11/15/99 <i>continued</i>		<ul style="list-style-type: none"> • While road testing the vehicle in a safe area and manner, conduct an acceleration test. For vehicles equipped with an automatic transmission conduct a 0-60 mph acceleration test. For vehicles equipped with a manual transmission, conduct a 40-60 mph acceleration test in fourth gear. It may take the technician performing several acceleration tests to obtain consistent acceleration times. A performance vehicle/tire size/weight chart is provided. A summary of the chart reveals 0-60 mph test for automatic trucks 13.5 to 15 seconds acceptable. In the 40 to 60 mph test, for manual trucks in fourth gear, can vary from 7.5 to 9.0 seconds. Correction factors for vehicle weight and altitude are presented.
18-24-99 11/15/99	'00 (BR)	<p><i>5.9L - 24V diesel engine intermittent engine stumble.</i></p> <p>This information applies to vehicles equipped with a 5.9L - 24V diesel engine built before engine serial number 56624822 with a date of manufacture of August 28, 1999. This information is available on the engine data plate, which is located on the left side of the engine, affixed to the gear housing. The customer may experience a quick, momentary stumble while driving or when stopped with the engine running. This condition is intermittent and may occur at any time during the operation of the vehicle. A change to the Cummins CM551 Engine Control Module (ECM) software corrects this condition (calibration change 99CalT9A).</p>

CATEGORY 19**STEERING**

<u>TSB #</u>	<u>MODELS</u>	<u>SUBJECT/DESCRIPTION</u>
19-03-99 05/07/99	'94-'99 (BR)	<p><i>Steering slow to return to center.</i></p> <p>This bulletin supersedes technical service bulletin 19-01-94, dated January 28, 1994. This bulletin applies to 4x4 vehicles equipped with a Dana model 60 front axle (sales code DRD). The rate of steering return to center (after turning a corner) may be slower than normal or may require slight steering wheel correction while driving straight ahead. The repair involves performing a ball joint tightening sequence.</p>
19-04-99 05/28/99	'99 (BR)	<p><i>Steering system diagnosis.</i></p> <p>Customers may complain that the steering system "feels heavy" or the steering wheel is not centered while driving on a straight road. The steering gear used on the 1999 Ram Truck is designed to have a heavy on-center steering characteristic. Before replacing a steering gear for a steering system "feel" complaint, perform the suggested diagnosis to ensure that the rest of the steering system components perform as designed.</p>

CATEGORY 21**TRANSMISSION**

<u>TSB #</u>	<u>MODELS</u>	<u>SUBJECT/DESCRIPTION</u>
21-08-99 04/30/99	'96-'99 (BR)	<p><i>Buzz, whine or moaning-type noise from a cold transmission when reverse is selected.</i></p> <p>Some vehicles may exhibit an intermittent noise from the transmission when reverse gear is selected. This noise has been described as a buzz, whining, or moaning-like noise. The noise is most noticeable when transmission fluid temperature is below 100 degrees F (38C). The condition is caused by a resonance of the transmission regulator valve system. The repair involves replacing the transmission regulator valve.</p>
21-14-99 11/05/99	'00 (BR)	<p><i>47RE transmission - harsh or early shifts.</i></p> <p>This information applies to vehicles equipped with a 5.9L - 24V diesel engine and 47RE automatic transmission built before engine serial number 56624822 with a date of manufacture of August 28, 1999. This information is available on the engine data plate, which is located on the left side of the engine, affixed to the gear housing.</p> <p>Some early-built 2000 model year Ram Trucks may experience a harsh 3-4 shift. This condition may occur during any throttle position situation when transmission sump temperatures are 60 degrees F (15C) or higher. The harsh 3-4 shift may be more pronounced during heavy vehicle loading, e.g., trailer towing. Some 2000 M.Y vehicles may also experience an early 1-2 or 2-3 shift condition during wide open throttle (WOT) situations. This condition may have an impact on vehicle performance (acceleration). This condition may occur when transmission sump temperatures are 32 degrees F (0C) or higher. Changes to the Cummins CM551 engine control module (ECM) software/calibration corrects the above two conditions (calibration change 00Cal57T9A).</p>

CATEGORY 21 TRANSMISSION

<u>TSB #</u>	<u>MODELS</u>	<u>SUBJECT/DESCRIPTION</u>
21-19-99 11/12/99	'99-'00 (BR)	<p><i>47RE delayed TCC lock-up and/or MIL P1740 = TCC or O/D solenoid performance.</i></p> <p>This information applies to vehicles built for the California market (NAE), equipped with a 5.9L - 24V diesel engine and built between March 2, 1999 and October 1, 1999. The customer may experience a delayed torque converter clutch engagement (lock-up). This condition may illuminate the Malfunction Indicator Lamp (MIL) due to Diagnostic Trouble Code (DTC) P1740 - TCC or O/D Solenoid Performance. In some situations, the customer may describe the condition as a lack of a transmission shift (TCC lock-up) between 30 and 50 mph. The transmission valve body upper housing separator plate was revised (wider slot) to improve fluid flow to the torque converter clutch. This bulletin describes the replacement of the transmission valve body upper housing separator plate.</p>

CATEGORY 23 BODY

<u>TSB #</u>	<u>MODELS</u>	<u>SUBJECT/DESCRIPTION</u>
23-08-99 03/05/99	'94-'99 (BR)	<p><i>Instrument panel creak.</i></p> <p>This bulletin supersedes technical service bulletin 23-45-96, dated August 2, 1996. A creak or squeak may be present near the left and/or right side(s) of the instrument panel. The noise is caused by the sheet metal joint between the A-pillar and the dash panel plenum lower rubbing together. This bulletin describes the repair procedure which involves loosening the instrument panel and providing additional clearance between the A-pillar inner panel and dash panel.</p>
23-18-99 05/21/99	'98-'99 (BR)	<p><i>Bezel comes loose from seat belt retractor cover.</i></p> <p>This bulletin applies to club/quad cab vehicles. The seat belt retractor cover bezel comes loose due to a cracked seat belt retractor cover. The crack may occur at the bottom of the opening where the seat belt bezel snaps into the cover. This bulletin describes the installation of a new seat belt retractor cover.</p>
23-22-99 07/02/99	'94-'00 (BR)	<p><i>Rattle in door area.</i></p> <p>This bulletin supersedes technical service bulletin 23-46-96, dated August 2, 1996. Customers may complain of one or more of the following symptoms: rattle heard in the door area; door window shakes when closing; door lower window channel bolt has pulled through the door sheet metal; door sheet metal is cracking around the lower window channel bolt. This bulletin involves removing the window channel from the door and installing a revised window channel.</p>
23-28-99 08/13/99	'98-'99 (BR)	<p><i>Power seat track vertical adjustment stuck in a full upward or full downward position.</i></p> <p>This bulletin applies to club or quad cab vehicles built before March 1, 1999. The repair condition is that the front and/or rear power seat track vertical adjuster motors are stuck in a full upward or full downward position. The repair involves removing existing lubrication on the power seat track adjustment lead screws and then applying a new lubricant.</p>
23-35-99 Rev. A 10/01/99	'94-'00 (BR)	<p><i>Child seat tether anchors.</i></p> <p>This bulletin supersedes technical service bulletin 23-35-99 dated September 3, 1999. This bulletin identifies the parts and labor operation numbers necessary to install a child seat tether anchor.</p>

TECHNICAL SERVICE BULLETINS ISSUED DURING 2000

CATEGORY 2 FRONT SUSPENSION

<u>TSB #</u>	<u>MODELS</u>	<u>SUBJECT/DESCRIPTION</u>
02-04-00 Rev. A 05/12/00	'94-'01 (BR)	<i>Squeaking/clicking noise from rear leaf springs.</i> If the vehicle has a squeaking/clicking noise coming from the rear of the vehicle, verify that the noise is coming from the rear springs as the vehicle's suspension goes through jounce and rebound. If a squeaking/clicking noise is coming from the rear springs, perform the repair procedure. The procedure involves replacing the spring tip liners and installing spring clinch clip insulators.

CATEGORY 25 BRAKES

<u>TSB #</u>	<u>MODELS</u>	<u>SUBJECT/DESCRIPTION</u>
05-04-00 05/01/00	'00 (BR)	<i>High pitched squeal from rear brakes.</i> This bulletin applies to 2500/3500 series Ram trucks built before March 1, 2000. The condition discussed is a high-pitched squeal coming from the rear brakes when the brakes are applied. The repair procedure involves installing revised rear brake shoes.
05-06-00 06/09/00	'00-'01 (BR)	<i>Front brake caliper anti-rattle clip retainer service procedures.</i> This bulletin applies to vehicles built before June 26, 2000. Vehicles built between April 19, 2000, and June 26, 2000, were built with a front brake caliper anti-rattle clip retainer. This Technical Service Bulletin provides the installation procedures for the retainer.

CATEGORY 8 ELECTRICAL

<u>TSB #</u>	<u>MODELS</u>	<u>SUBJECT/DESCRIPTION</u>
08-05-00 04/21/00	'99 (BR)	<i>Intermittent operation of the instrument cluster.</i> The needle of the instrument cluster gauges may intermittently drop to zero and/or the telltale lamps, such as the AIRBAG warning lamp, may intermittently come on. The bulletin involves replacing the instrument cluster wire harness connector and associated wire terminals.
08-08-00 03/17/00	'99-'00 (BR)	<i>Inoperative or intermittent remote keyless entry (RKE) transmitter.</i> The problem described is an inoperative RKE transmitter. This condition may be intermittent and will have similar symptoms to a dead transmitter battery. This bulletin discusses replacing and reprogramming the (RKE) transmitter.
08-11-00 03/24/00	'94-'00 (BR)	<i>Recordable compact discs used in automotive CD players.</i> Some recordable compact disc media, such as CD-R and CD-RW, may not comply with the standard CD format used in automotive CD players. When these CDs are used, customers may encounter error messages skipping, or delaminating of the labels, which can cause an eject failure. It is important to question whether these kinds of CD media are being used. When customers encounter these symptoms, check the system with a known playable CD. The media may not be compatible with some automotive CD players. Replacing or exchanging the CD player will not address these issues.
08-16-00 04/28/00	'94-'00 (BR)	<i>Front door speaker buzz.</i> The bulletin discusses a buss noise coming from the front door speaker(s). The noise may be more noticeable while listening to "talk" radio segments with deep male voices. The repair procedure involves installing a urethane foam pad between the inner door panel and the door trim.
08-17-00 05/12/00	'96-'00 (BR)	<i>Intermittent speaker operation/static.</i> Intermittent operation/static may occur in any or all speakers. The bulletin applies to vehicles equipped with the Infinity sound system sales codes (RBR, RBN, and RAZ) built before October 1, 1999. This repair involves installing new speaker kits on both right and left front doors and installing foam between the inner door trim panel and the door.
08-18-00 05/12/00	'98-'01 (BR)	<i>Radio Interference to/from two-way radio receivers.</i> Customers may complain of intermittent poor reception on their two-way radios. This bulletin involves installing a RFI filter in series with the electric fuel pump motor.

CATEGORY 8**ELECTRICAL**

<u>TSB #</u>	<u>MODELS</u>	<u>SUBJECT/DESCRIPTION</u>
08-23-00 06/23/00	'98-'01 (BR)	<p><i>Plastic boot to protect the electrical harness B+ end terminal at the generator.</i></p> <p>While service is being performed to the engine, it may be possible for a momentary electrical short to occur. The electrical short may be caused when a metallic object, such as a wrench or oil filter, comes in contact with the B+ end terminal of the generator wire harness. The B+ end terminal is bolted to the generator B+ stud (output terminal). The B+ stud on the generator is protected by a plastic surround. Part of the wire harness end terminal may extend beyond the protective plastic surround for the B+ output terminal.</p> <p>This bulletin applies to vehicles equipped with a 5.9L – 24V diesel engine built before engine serial number 56681800 with a date of manufacture of January 29, 2000. The repair procedure involves the installation of a protective rubber boot (part number 04487042) over the B+ terminal.</p>
08-26-00 09/29/00	'00-'01 (BR)	<p><i>Central timer module electrically “locks-up.”</i></p> <p>This bulletin applies to vehicles equipped with remote keyless entry (sales code GXR). In addition, this bulletin applies to vehicles built on or before the following build dates: Ram trucks built at the St. Louis North Assembly Plant on or before August 21, 2000; Ram trucks built at the Saltillo Truck Assembly Plant on or before August 31, 2000; Ram trucks built at the Lago Alberto Truck Assembly Plant on or before September 6, 2000. The repair involves replacing the Central Timer Module (CTM) with a revised part.</p>

CATEGORY 9**ENGINE**

<u>TSB #</u>	<u>MODELS</u>	<u>SUBJECT/DESCRIPTION</u>
09-03-00 02/18/00	'99-'00 (BR)	<p><i>A heavy oil or fuel-like odor coming from the diesel engine compartment.</i></p> <p>This bulletin applies to vehicles equipped with a 5.9L diesel engine. The problem is a heavy oil or fuel-like odor coming from the engine compartment. This condition may occur after the engine oil has been changed. The odor appears to reduce in intensity as the engine oil ages. This aging usually occurs between the first 300 to 500 miles following the oil change.</p> <p>The odor condition is the result of certain diesel engine oil additives. These oil additives are blended with the base oil during the manufacture of the engine oil. Some diesel engine oils with the American Petroleum Institute quality rating of CH-4 or CH-4+ may be more prone to exhibiting the odor condition.</p> <p>The DaimlerChrysler recommended diesel engine oil (p/n 04798231 or p/n 0479832) is formulated to minimize the heavy oil odor condition.</p>
09-03-00 02/18/00	'00 (BR)	<p><i>Engine oil seepage past the oil fill cap on 5.9L-24V diesel engine.</i></p> <p>This bulletin applies to vehicles equipped with a 5.9L-24V diesel engine built before engine serial number 56664950 with a date of manufacture of December 8, 1999.</p> <p>Oil seepage may be noticed in the area of the oil fill cap. This may be due to paint overspray around the oil fill opening of the cylinder head valve cover. The paint overspray may cause an uneven sealing surface. The corrective action involves using fine grit sandpaper to insure a smooth mating surface.</p> <p>Another possible cause for the oil seepage may be a damaged oil fill cap o-ring. The o-ring may be cut due to the presence of a sharp corner around the top edge of the cylinder head cover oil fill opening.</p>

CATEGORY 14**FUEL**

<u>TSB #</u>	<u>MODELS</u>	<u>SUBJECT/DESCRIPTION</u>
14-01-00 02/04/00	'00 (BR)	<p><i>Thump/bump sound heard 1-3 seconds after the vehicle comes to a stop.</i></p> <p>This bulletin applies to 2500 series Club/Quad cab vehicles equipped with the 6 ½ foot box built before December 1, 1999.</p> <p>Customers may hear a thump/bump sound that occurs 1-3 seconds after the vehicle comes to a complete stop. In some cases, the thump/bump sound may be transmitted through the floor of the vehicle allowing the customer to feel the thump/bump in the floor pan of the vehicle. The sound will only occur when the fuel level of the vehicle is between ½ and 7/8 tank of fuel.</p> <p>Since the fuel level of the vehicle must be between ½ to 7/8 full, the condition may be difficult to diagnose. The repair involves replacing the fuel tank.</p>
14-02-00 04/14/00	'00-'01 (BR)	<p><i>Crack in diesel fuel filter housing cover caused by an improper servicing procedure.</i></p> <p>This bulletin applies to vehicles equipped with a 5.9L-24V diesel engine built before engine serial number 56686747 with a date of manufacture of February 09, 2000. Analysis of returned fuel filter housing covers has determined that a number of plastic covers are being replaced due to cracks. Further analysis has revealed that the cracks may be caused by improper cover removal procedures. Do not use the square opening to remove or install the cover. The fuel filter cover may crack. To remove or install the fuel filter cover correctly, only use the 1 1/8" hex head. Use of a six point socket is preferred.</p>
14-03-00 04/14/00	'98-'01 (BR)	<p><i>Maintenance to the Water-In-Fuel sensor probes due to possible fuel contamination.</i></p> <p>The probes on the end of the Water-In-Fuel (WIF) sensor may become less effective at sensing the presence of water in the fuel if they are exposed to contaminated fuel. Contaminant from the fuel may insulate the WIF sensor probes and inhibit the WIF lamp from illuminating when water is present.</p> <p>Any time service is performed on the fuel filter or fuel filter housing, the probes on the end of the Water-In-Fuel sensor should be cleaned. Use a clean cloth to wipe the WIF probes of any contaminant.</p>

CATEGORY 18**VEHICLE PERFORMANCE**

<u>TSB #</u>	<u>MODELS</u>	<u>SUBJECT/DESCRIPTION</u>
18-015-00 Rev. A 12/21/00	'99-'00 (BR)	<p><i>Driveability enhancements for winter fuel use and for hard starts.</i></p> <p>This bulletin applies to vehicles equipped with a 5.9L-24V diesel engine built between engine serial numbers 56419738 to 56798357, with a date of manufacture of December 16, 1997 to November 15, 2000.</p> <p>The customer may complain of poor driveability when winter fuel is used to power the engine. Or, the customer may complain of a hard or no-start condition, while the engine is at normal operating temperatures, when using any type of good quality diesel fuel. The poor driveability condition may occur only when either straight #1 diesel fuel is used or when other special cold climate winter blend fuels are in use.</p> <p>The no-start or long engine crank condition may occur when attempting to restart the engine while the temperature of the engine is till close to its normal operating temperature. This hard hot restart condition may be experienced in all ambient climates, but may be more of a concern in warmer ambient climates. The repair involves selectively erasing and reprogramming the Cummins CM551 Engine Control Module (ECM) with new software.</p>
09-03-00 02/18/00	'00 (BR)	<p><i>Engine oil seepage past the oil fill cap on 5.9L-24V diesel engine.</i></p> <p>This bulletin applies to vehicles equipped with a 5.9L-24V diesel engine built before engine serial number 56664950 with a date of manufacture of December 8,j 1999.</p> <p>Oil seepage may be noticed in the area of the oil fill cap. This may be due to paint overspray around the oil fill opening of the cylinder head valve cover. The paint overspray may cause an uneven sealing surface. The corrective action involves using fine grit sandpaper to insure a smooth mating surface.</p> <p>Another possible cause for the oil seepage may be a damaged oil fill cap o-ring. The o-ring may be cut die to the presence of a sharp corner around the top edge of the cylinder head cover oil fill opening.</p>

CATEGORY 18**VEHICLE PERFORMANCE****TSB # MODELS SUBJECT/DESCRIPTION**

18-015-00 '99-'00 (BR)
Rev. A
12/21/00

Low engine power when the automatic transmission is in overdrive.

This bulletin applies to vehicles equipped with a 24-valve diesel engine and automatic transmission built between engine serial numbers 56666444 to 56798357, with a date of manufacture of December 15, 1999 to November 15, 2000. This information is available on the engine data plate, which is located on the left side of the engine, affixed to the side of the timing gear housing.

The customer may complain of low engine power and/or poor performance. This engine condition may occur while the automatic transmission is being operated in its overdrive gear. This condition may be further aggravated if the customer is using the vehicle for towing purposes.

The Engine Control Module (ECM) software, on a 2001 Ram Truck equipped with a 24-valve diesel engine, is designed to "torque manage" the power output of the engine. This is done to protect the automatic transmission components. The revised software calibration restores the power output and improves the vehicle performance in overdrive.

Note: If TSB 18-015-00 Rev A has previously been performed too the vehicle in question, then the ECM software has already been revised with the correct calibration to address the above condition. The ECM will not require reprogramming.

The repair procedure involves selectively erasing and reprogramming the Cummins CM551 Engine Control Module (ECM) with new software (calibration versions: 56T13, 59T6). There is no change to the JTEC PCM software.

CATEGORY 19**STEERING****TSB # MODELS SUBJECT/DESCRIPTION**

19-04-00 '94-'00 (BR)
06/09/00

This bulletin applies to vehicles equipped with non-tilt steering columns. A squeaking/creaking sound may be heard coming from the area of the steering wheel while turning. The sound is associated with rotation fo the steering wheel or may be heard while going over bumps in the road. The repair involves installing new lock housing attaching screws.

CATEGORY 21**TRANSMISSION****TSB # MODELS SUBJECT/DESCRIPTION**

21-02-00 '99-'00 (BR)
03/10/00

47RE transmission-delayed upshift or no TCC engagement between 30 and 50 MPH.

This bulletin applies to vehicles equipped with a federal market 5.9L-24V diesel engine and built between March 2, 1999 and October 1, 1999.

The customer may experience a condition where the transmission may seem to have a delayed 3-4 upshift, while moderately accelerating from 30 to 50 MPH. The customer may also note high engine rpm's while operating in third or fourth gear. This condition may be caused by a delay in the engagement of the transmission torque converter clutch (torque converter lockup). The repair involves the replacement of the transmission valve body upper housing separator plate.

21-04-00 '96-'99 (BR)
06/30/00

Erroneous MIL illumination for P1763 – Transmission Governor Pressure Sensor Volts Too High.

Some vehicles may exhibit a MIL illumination with a Diagnostic Trouble Code (DTC) of P1763 – Transmission Governor Pressure Sensor Volts Too High. The vehicle operator may experience slower than normal vehicle accelerations because the transmission may have temporarily entered its third gear "limp-In" mode as a result of the DTC. The "Limp-In" mode may last until the vehicle owner cycles the ignition key. The technician may not detect a problem with the automatic transmission during a diagnostic test or test drive.

The MIL is caused by an increase in hydraulic pressure. The increased hydraulic pressure is the result of a new valve body machining process, which entered into production January 1, 1998. This condition will occur most often with vehicles that were built between January 1, 1998 and December 18, 1998.

Vehicles built prior to January 1, 1998 may also experience this condition if the valve body or the transmission assembly is replaced with components built after January 1, 1998.

This bulletin involves selectively erasing and reprogramming the JTEC Powertrain Control Module (PCN) with new software.

CATEGORY 21 TRANSMISSION

<u>TSB #</u>	<u>MODELS</u>	<u>SUBJECT/DESCRIPTION</u>
21-08-00 09/01/00	'99-'00 (BR)	<p><i>47RE transmission-delayed upshift or no TCC engagement between 30 and 50 MPH.</i></p> <p>This bulletin applies to vehicles equipped with a federal market 5.9L-24V diesel engine and built between March 2, 1999 and October 1, 1999.</p> <p>The customer may experience a condition where the transmission may seem to have a delayed 3-4 upshift, while moderately accelerating from 30 to 50 MPH. The customer may also note high engine rpm's while operating in third or fourth gear. This condition may be caused by a delay in the engagement of the transmission torque converter clutch (torque converter lockup). The repair involves the replacement of the transmission valve body upper housing separator plate.</p>
21-12-00 09/15/00	'00-'01 (BR)	<p><i>Tapping/knocking sound during idle.</i></p> <p>This bulletin applies to vehicles built before May 10, 2000, equipped with an automatic transmission. A tapping/knocking sound may be heard or felt in the driver side floor pan area during idle conditions. With the engine running at an idle, listen for knocking sound coming from the driver side floor pan area. If a tapping/knocking sound can be heard, replace the shift linkage with revised parts.</p>

CATEGORY 23 BODY

<u>TSB #</u>	<u>MODELS</u>	<u>SUBJECT/DESCRIPTION</u>
23-03-00 02/04/00	'00 (BR)	<p><i>Vehicle Identification Number (VIN) Plate Relocated</i></p> <p>The VIN plate on the subject model vehicles has been relocated from the instrument panel to the cowl bar. Due to the relocation of the VIN plate, the windshield frit (the frit is the black-out band at the bottom of the windshield) required a change so that the VIN plate could be seen through the windshield. The view of the VIN plate may be blocked if a 1999 or earlier windshield is installed on the vehicle.</p> <p>Do not install or have class suppliers install 1999 or earlier windshields on 2000 model year subject model vehicles. Likewise, do not install or have glass suppliers install 2000 or later windshields on earlier models.</p>
23-19-00 05/05/00	'94-'01 (BR)	<p><i>Instrument panel creak.</i></p> <p>A creak or squeak may be present near the left and/or right side(s) of the instrument panel. The noise is caused by the sheet metal joint between the A-pillar and the dash panel plenum lower rubbing together. The repair involves loosening that instrument panel and providing additional clearance between the A-pillar inner panel and dash panel.</p>
23-25-00 06/30/00	'97-'01 (BR)	<p><i>Paint fogging/whitening.</i></p> <p>Painted surfaces of the vehicle that are covered for extended periods of time with front end covers (bras), transit films or magnetic signs may appear to have a white "milky" spot on dark colors, or a fogging, coffee colored spot lighter colors. The repair involves removal of a fogging or staining condition from any painted surface where moisture may be trapped under the clear coat by using a heat gun.</p>

TECHNICAL SERVICE BULLETINS ISSUED DURING 2001

CATEGORY 2 FRONT SUSPENSION

<u>TSB #</u>	<u>MODELS</u>	<u>SUBJECT/DESCRIPTION</u>
02-001-01 1/19/01	'94-'01 (BR)	<p><i>Rear of vehicle sits too high to allow hook up to a fifth-wheel trailer.</i></p> <p>This bulletin applies to 2500 and 3500 4x4s. The curb height lowering package is designed to reduce the rear spring spacer block by 1-7/8 inch, which will lower the rear of the vehicle by several inches providing clearance so that most customers can attach their fifth-wheel or goose neck trailer to the trailer hitch turntable.</p>

CATEGORY 5 BRAKES

<u>TSB #</u>	<u>MODELS</u>	<u>SUBJECT/DESCRIPTION</u>
05-002-01 3/9/01	'01	<p>This bulletin applies to vehicles equipped with non-tilt steering columns. A squeaking/creaking sound may be heard coming from the area of the steering wheel while turning. The sound is associated with rotation of the steering wheel or may be heard while going over bumps in the road. The repair involves installing new lock housing attaching screws.</p>

CATEGORY 8 ELECTRICAL

<u>TSB #</u>	<u>MODELS</u>	<u>SUBJECT/DESCRIPTION</u>
08-010-01 5/25/01	'94-'02	<p><i>Airbag/clock spring service.</i></p> <p>When servicing any airbag system, it is essential to follow the proper Service Manual and/or Diagnostic Manual procedures for diagnosing, testing, and replacing of any component. Do not use silicone or any other lubricant spray on or near the clock spring. Lubricants are often used in the clock spring area of the steering column to eliminate noise. Any repair that may disrupt the positioning of the steering wheel with the front wheels will require that the clock spring be centered. This includes clock spring replacement, steering column service, HVAC service, steering gear service, and front suspension crossmember service.</p>

CATEGORY 9 ENGINE

<u>TSB #</u>	<u>MODELS</u>	<u>SUBJECT/DESCRIPTION</u>
09-002-01 03/02/01	'98-'01 (BR)	<p><i>Exhaust manifold bolt retention straps.</i></p> <p>This bulletin applies to vehicles equipped with a 24-valve diesel engine built on or between engine serial number 56419738 and 56777585, with a date of engine manufacture from January 01, 1998 to September 22, 2000. This information is available on the engine data plate, which is located on the left side of the engine, affixed to the side of the timing gear housing.</p> <p>Vehicles that are used for extended heavy trailer hauling purposes may experience a loss of exhaust manifold bolt torque. This condition may lead to exhaust gas blow-by past the exhaust manifold gasket(s) and even loss of exhaust manifold bolts.</p> <p>A new exhaust manifold bolt retention strap has been released as a means of locking the outboard exhaust manifold bolts in place. This will prevent bolt rotation and torque loss during the thermal expansion and contraction cycles of the exhaust manifold.</p>
09-001-01 1/19/01	'01	<p><i>Intermittent loss of oil pressure sensor output voltage.</i></p> <p>This bulletin applies to 2500/3500 diesels with engine serial number 56744083 to 56809910. The output voltage of the oil pressure sensor may intermittently dropout. This condition may cause the engine oil pressure gauge needle to erroneously indicate lower than actual oil pressure. A warning chime may sound and the "Check Gauges" lamp may illuminate. The Engine Control Module (ECM) software has been revised to address this condition. Replacing the oil pressure sensor will not correct this condition.</p>

CATEGORY 9**ENGINE**

<u>TSB #</u>	<u>MODELS</u>	<u>SUBJECT/DESCRIPTION</u>
09-003-01 5/4/01	All	<i>Engine oil additives/supplements.</i> Engine oil additives/supplements (EOS) should not be used to enhance engine oil performance. Engine oil additives/supplements should not be used to extend engine oil change intervals. No additive is known to be safe for engine durability and can degrade emission components. Additives can contain undesirable materials that harm the long term durability of engines. Generally it is not desirable to mix additive packages from different suppliers in the crankcase; there have been reports of low temperature of low temperature engine failures caused by additive package incompatibility with such mixtures.
09-006-01 08/24/01	'98-'02	<i>Engine oil pan gasket sealing.</i> This bulletin applies to Ram trucks equipped with the 24-valve diesel engine. Repeat oil pan gasket leaks can occur on 24-valve diesels if the gasket is applied without the use of Mopar Silicon Rubber Adhesive (RTV) sealant (PN 04883971). This bulletin provides specific routing of the sealant when replacing the engine oil pan gasket. When replacing an oil pan gasket, apply a 1/8" bead of RTV to the oil pan side of the gasket, around the back of the engine, extending up to the fourth bolt hole from the rear on each side, as per the referenced diagram.
To be determined	'94-'02 (BR)	<i>Crankcase breather overflow.</i> This bulletin applies to '98 - '02 (BR) Ram trucks equipped with the 24-valve Cummins diesel engine built after March 27, 1998 (ESN 56443872). Owners of '98 - '02 trucks equipped with the 24-valve Cummins diesel engine may experience engine oil overflow from the front crankcase breather when the vehicle is operated on an extreme downhill grade (36.5% or 22° slope/grade). Operation of this type for extended periods of time can cause enough engine oil depletion to damage the engine. A kit containing all components necessary to eliminate the oil overflow has been made available. The bulletin outlines the repair procedure that relocates the breather from the front of the engine to a new location on the driver's side tappet cover.

CATEGORY 18**VEHICLE PERFORMANCE**

<u>TSB #</u>	<u>MODELS</u>	<u>SUBJECT/DESCRIPTION</u>
09-002-01 03/02/01	'98.5-'02 (BR/BE)	<i>Cold idle engine warming.</i> This bulletin involves selectively erasing and reprogramming the Engine Control Module with new software. This bulletin applies to all Ram trucks built after December 17, 1997 equipped with the 24-valve 5.9L Cummins diesel engine. Extended idle operation, especially in cold weather, can allow varnishes/oils to condense on the exhaust valve stems, leading to stuck valves, and damaged valve train components. The repair procedure involves calibration software that will activate when certain parameters are met, reducing the chance of valve sticking as well as improving cab heat warm-up time. Idle speed will slowly ramp up from 800 rpm to 1200 rpm when all of the following conditions are met: <ul style="list-style-type: none"> • Intake Manifold Temperature less than 60°C (32°F) • Coolant Temp is less than 60°C (140°F) • The transmission is in Neutral or Park • The Service Brake pedal is not depressed • Throttle = 0% • Vehicle Speed = 0 mph If intake manifold temperature (IMT) is less than -9°C (15°F), three of the cylinders will be shut off upon reaching 1200 rpm, creating a slight change in engine sound which is normal. Thus the engine has to work to overcome the three "dead" cylinders. This allows the engine to create increased heat in the cooling system, allowing more rapid warm up. Either feature will abort when any one of the following occurs: <ul style="list-style-type: none"> • The automatic transmission is placed in gear (forward or reverse) • The service brake pedal is depressed • Throttle position is greater than 0% • Vehicle speed greater than 0 mph • Coolant temperature is greater than 79°C (175°F)

CATEGORY 21**TRANSMISSION**

<u>TSB #</u>	<u>MODELS</u>	<u>SUBJECT/DESCRIPTION</u>
09-002-01 03/02/01	'01 (BR)	<p><i>Overdrive disabled to improve transmission reliability during cold temperature operation.</i></p> <p>This bulletin applies to vehicles equipped with an automatic transmission where the vehicle was built on or between June 26, 2000 and December 23, 2000, and the PCM software level is earlier (lower) than calibration 14 for model year 2001.</p> <p>Quality analysis has determined that insufficient lubrication of certain internal transmission components may occur when a vehicle is operated in temperatures lower than -20°C (-5°F). This condition may be caused by the automatic transmission fluid (ATF) freezing in the cooler lines and interrupting the flow of lubricating oil (ATF) to the transmission overdrive unit. This condition should be a concern only in areas where very cold ambient temperatures of -20°C (-5°F) are experienced.</p> <p>The revised software will not allow 4th gear overdrive to occur if ambient temperatures are less than -20°C (-5°F). The revised PCM software has been implemented to improve transmission reliability. The customer should be informed that reduced fuel economy would be expected when overdrive is not in use.</p> <p>The repair involves selectively erasing and reprogramming the Powertrain Control Module (PCM) with new software (calibration level 01Cal14).</p>

CATEGORY 21**TRANSMISSION**

<u>TSB #</u>	<u>MODELS</u>	<u>SUBJECT/DESCRIPTION</u>
25-001-01 1/19/01	'01 (BR/BE)	<p><i>Generic Scan Tool May Not Display Certain DTC's and Erroneous LDP Switch.</i></p> <p>This bulletin applies to vehicles with an RE automatic transmission built before January 12, 2001 (MDH 0112XX). A generic scan tool may not display certain Diagnostic Trouble Codes (DTC) when a Malfunction Indicator Lamp (MIL) illuminates. The PCM software must be updated to calibration level 01Call4A.</p>
25-002-01 1/19/01	'01 (BR/BE)	<p><i>Scan Tool Erroneously Displays P000 For DTC's P1740 And P0461.</i></p> <p>This bulletin applies to vehicles with an RE automatic transmission built before January 31, 2001 (MDH 0131XX). A Generic Scan Tool or an Enhanced Scan Tool, like the DRB III, may erroneously display certain Diagnostic Trouble Codes (DTC) as P0000. As a result, the scan tool may display Freeze Frame data incorrectly. The PCM software must be updated to calibration level 01Call4A.</p>

TECHNICAL SERVICE BULLETINS ISSUED DURING 2002

CATEGORY 2 FRONT SUSPENSION

<u>TSB #</u>	<u>MODELS</u>	<u>SUBJECT/DESCRIPTION</u>
02-001-01 1/19/01	'94-'01	<i>Rear of vehicle sits too high to allow hook up to a fifth-wheel trailer.</i> This bulletin applies to 2500 and 3500 4x4s. The curb height lowering package is designed to reduce the rear spring spacer block by 1 7/8 inch, which will lower the rear of the vehicle by several inches providing clearance so that most customers can attach their fifth-wheel or goose neck trailer to the trailer hitch turntable.

CATEGORY 5 BRAKES

<u>TSB #</u>	<u>MODELS</u>	<u>SUBJECT/DESCRIPTION</u>
05-002-01 3/9/01	'01	<i>Parking brake pedal adjustment.</i> This bulletin applies to 2500/3500 series Ram trucks with four-wheel disc brakes, built before November 20, 2000. Parking brake cable appears to be mis-adjusted, which may cause the parking brake lamp to remain illuminated even after the parking brake pedal has been released. The parking brake system, however, is not mis-adjusted and functions normally. Install new parking brake cables.

CATEGORY 8 ELECTRICAL

<u>TSB #</u>	<u>MODELS</u>	<u>SUBJECT/DESCRIPTION</u>
08-010-01 5/25/01	'94-'02	<i>Airbag/clock spring service.</i> When servicing any airbag system, it is essential to follow the proper Service Manual and/or Diagnostic Manual procedures for diagnosing, testing, and replacing of any component. Do not use silicone or any other lubricant spray on or near the clock spring. Lubricants are often used in the clock spring area of the steering column to eliminate noise. Any repair that may disrupt the positioning of the steering wheel with the front wheels will require that the clock spring be centered. This includes clock spring replacement, steering column service, HVAC service, steering gear service, and front suspension crossmember service.
08-016-01 8/3/01	'02 (BR/BE)	<i>Locking radio antenna connector.</i> This information only bulletin applies to all 2002 vehicles equipped with radios. The radio units will have a new locking radio antenna connector. This connector requires that a sliding plastic collar be pulled away from the radio, similar to an air hose connector, to release the lock. Pulling the antenna out of the radio without activating the release could damage the antenna or the radio.
08-017-01 9/21/01	'02 (BR/BE)	<i>Safety systems -- Vehicle modifications/repair.</i> Any of the safety systems may be disabled by inadvertent damage to wiring or system components or by changing or modifying the location of a component.
08-025-01 11/23/01	'94-'01 (BRE)	<i>Airbag on-off switches.</i> This bulletin supersedes technical service bulletin 08-037-99, dated 11/12/99. This bulletin is provided to identify the parts and procedures necessary to deactivate airbags authorized by NHTSA. Airbag deactivation is a customer pay procedure, not covered under the provisions of the warranty. The component parts are covered under the appropriate Mopar part warranty. DaimlerChrysler Corporation is now offering airbag on-off switches for the selected vehicles listed above. The switches are packaged in a kit containing all necessary parts (except as indicated) and a detailed instruction sheet. Under the National Highway Traffic Safety Administration's rule, consumers will be authorized for on-off switches by claiming they meet any of several criteria. Airbag on-off switches must not be installed without the vehicle owner presenting the NHTSA authorization letter. For more information concerning the authorization process and/or the authorization letter call NHTSA's Auto Safety Hotline at 1-800-424-9393. We encourage the dealer to install these switches when the customer is interested in doing so and has the necessary NHTSA authorization.

CATEGORY 9**ENGINE**

<u>TSB #</u>	<u>MODELS</u>	<u>SUBJECT/DESCRIPTION</u>																		
09-002-01 03/02/01	'98-'01 (BR)	<i>Exhaust manifold bolt retention straps.</i> This bulletin applies to vehicles equipped with a 24-valve diesel engine built on or between engine serial number 56419738 and 56777585, with a date of engine manufacture from January 01, 1998 to September 22, 2000. This information is available on the engine data plate, which is located on the left side of the engine, affixed to the side of the timing gear housing.																		
09-001-01 1/19/01	'01	<i>Intermittent loss of oil pressure sensor output voltage.</i> This bulletin applies to 2500/3500 diesels with engine serial number 56744083 to 56809910. The output voltage of the oil pressure sensor may intermittently dropout. This condition may cause the engine oil pressure gauge needle to erroneously indicate lower than actual oil pressure. A warning chime may sound and the "Check Gauges" lamp may illuminate. The Engine Control Module (ECM) software has been revised to address this condition. Replacing the oil pressure sensor will not correct this condition.																		
09-003-01 5/4/01	All	<i>Engine oil additives/supplements.</i> Engine oil additives/supplements (EOS) should not be used to enhance engine oil performance. Engine oil additives/supplements should not be used to extend engine oil change intervals. No additive is known to be safe for engine durability and they can degrade emission components. Additives can contain undesirable materials that harm the long term durability of engines. Generally it is not desirable to mix additive packages from different suppliers in the crankcase; there have been reports of low temperature engine failures caused by additive package incompatibility with such mixtures.																		
09-004-01 5/18/01	'89-'93 (AD) '94-'01 (BR/BE)	<i>Engine lubricant.</i> This bulletin involves 1989 – 2001 Ram trucks equipped with the 5.9L Cummins diesel engines. This bulletin discusses the recommended oil filters for use with Cummins 5.9L diesel engine: <table border="1" data-bbox="568 945 1006 1207"> <thead> <tr> <th><u>Part No.</u></th> <th><u>Manufacturer</u></th> </tr> </thead> <tbody> <tr> <td>05016547AC</td> <td>Mopar</td> </tr> <tr> <td>LF3894</td> <td>Fleetguard Stratapore</td> </tr> <tr> <td>LF3552</td> <td>Fleetguard Microglass</td> </tr> <tr> <td>LF3959</td> <td>Fleetguard Cellulose</td> </tr> <tr> <td>3937695</td> <td>Cummins Cellulose</td> </tr> <tr> <td>FL896</td> <td>MotorCraft Cellulose</td> </tr> <tr> <td>L45335</td> <td>Purolator Cellulose</td> </tr> <tr> <td>PF1070</td> <td>AC Delco Cellulose</td> </tr> </tbody> </table> <p>The information only bulletin was issued to alert the field to problems caused by aftermarket oil filters. For example, neoprene compounds used internally in the manufacture of oil filters not recommended by DaimlerChrysler may separate from the filter, lodge in the piston cooling nozzle, and cause the engine to fail. THIS IS NOT AN ENGINE DEFECT.</p>	<u>Part No.</u>	<u>Manufacturer</u>	05016547AC	Mopar	LF3894	Fleetguard Stratapore	LF3552	Fleetguard Microglass	LF3959	Fleetguard Cellulose	3937695	Cummins Cellulose	FL896	MotorCraft Cellulose	L45335	Purolator Cellulose	PF1070	AC Delco Cellulose
<u>Part No.</u>	<u>Manufacturer</u>																			
05016547AC	Mopar																			
LF3894	Fleetguard Stratapore																			
LF3552	Fleetguard Microglass																			
LF3959	Fleetguard Cellulose																			
3937695	Cummins Cellulose																			
FL896	MotorCraft Cellulose																			
L45335	Purolator Cellulose																			
PF1070	AC Delco Cellulose																			
09-006-01 08/24/01	'98-'02 (BR)	<i>Engine Oil Pan Gasket Sealing</i> This bulletin applies to Ram trucks equipped with the 24-valve diesel engine. Repeated oil pan gasket leaks can occur on 24-valve diesels if the gasket is applied without the use of Mopar Silicon Rubber Adhesive (RTV) sealant (PN 04883971). This bulletin provides specific routing of the sealant when replacing the engine oil pan gasket. When replacing an oil pan gasket, apply a 1/8" bead of RTV to the oil pan side of the gasket, around the back of the engine, extending up to the fourth bolt hole from the rear on each side, as per the referenced diagram.																		
09-002-02 3/11/02	'98-'02 (BR)	<i>Crankcase Breather Overflow</i> This bulletin applies to '98 - '02 (BR) Ram trucks equipped with the 24-valve Cummins diesel engine built after March 27, 1998 (ESN 56443872). Owners of '98 - '02 trucks equipped with the 24-valve Cummins diesel engine may experience engine oil overflow from the front crankcase breather when the vehicle is operated on an extreme downhill grade (36.5% or 22° slope/grade). Operation of this type for extended periods of time can cause enough engine oil depletion to damage the engine. A kit containing all components necessary to eliminate the oil overflow has been made available. The bulletin outlines the repair procedure that relocates the breather from the front of the engine to a new location on the driver's side tappet cover.																		

CATEGORY 18**VEHICLE PERFORMANCE**

<u>TSB #</u>	<u>MODELS</u>	<u>SUBJECT/DESCRIPTION</u>
18-019-01 9/3/01	'98.5-'02 (BR/BE)	<p><i>Cold idle engine warming.</i></p> <p>This bulletin addresses selectively erasing and reprogramming the Engine Control Module with new software. This bulletin applies to all Ram trucks built after December 17, 1997, equipped with the 24-valve 5.9L Cummins diesel engine.</p> <p>Extended idle operation, especially in cold weather, can allow varnishes/oils to condense on the exhaust valve stems, leading to stuck valves, and damaged valve train components. The repair procedure involves calibration software that will activate when certain parameters are met, reducing the chance of valve sticking as well as improving cab heat warm-up time. Idle speed will slowly ramp up from 800 rpm to 1200 rpm when all of the following conditions are met:</p> <ul style="list-style-type: none"> • Intake Manifold Temperature is less than 60°C (32°F) • Coolant Temp is less than 60°C (140°F) • The transmission is in Neutral or Park • The Service Brake pedal is not depressed • Throttle = 0% • Vehicle Speed = 0 mph <p>If intake manifold temperature (IMT) is less than -9°C (15°F), three of the cylinders will be shut off upon reaching 1200 rpm, creating a slight change in engine sound which is normal. Thus the engine has to work to overcome the three "dead" cylinders. This allows the engine to create increased heat in the cooling system, allowing more rapid warm up.</p> <p>Either feature will abort when any one of the following occurs:</p> <ul style="list-style-type: none"> • The automatic transmission is placed in gear (forward or reverse) • The service brake pedal is depressed • Throttle position is greater than 0% • Vehicle speed is greater than 0 mph • Coolant temperature is greater than 79°C (175°F)

18-014-01 7/9/01	'98.5-'02 (BR/BE)	<p><i>Performance enhancement for severe cold weather environments.</i></p> <p>This bulletin applies to all Ram trucks equipped with a 5.9L 24-valve Cummins diesel engine with a 49-state emissions calibration and an automatic transmission. The bulletin describes how to selectively erase and reprogram the Powertrain Control Module (PCM) with new software (59t7a). The problem addressed by the PCM reprogram is a hard starting and/or idle speed fluctuations condition.</p> <p>Cummins 24-valve engines used with automatic transmissions can be severely affected by the use of sub-grade #1 diesel fuel when ambient temperatures are below 0°C (32°F), typically prevalent during the Winter months in Alaska, Northwestern Canada, and similar climates/temperatures elsewhere.</p> <p>This change will have no effect on performance during warm weather or when standard grade diesel fuels #1 or #2 are used.</p> <p>Vehicles with 49-state certification can apply this calibration change if needed. The calibration can be changed back to the original calibration if desired.</p>
---------------------	-------------------	--

CATEGORY 19**STEERING**

<u>TSB #</u>	<u>MODELS</u>	<u>SUBJECT/DESCRIPTION</u>
19-009-01 10/26/01	'97-'02 (BE/BR)	<p><i>Driver airbag trim cover service.</i></p> <p>Driver airbag trim covers/horn switches for the above vehicles are serviceable and as such, when applicable, must be used instead of replacing the airbag module assembly. Airbag module assemblies returned for trim cover and serviceable horn switch issues, are subject to charge back.</p> <p>The horn switch is integral to the driver airbag unit. Only DaimlerChrysler-trained and authorized dealer service technicians should perform service of this unit. Failure to take the proper precautions or to follow the proper procedures could result in accidental, incomplete, or improper airbag deployment and possible occupant injuries.</p>

CATEGORY 21**TRANSMISSION**

<u>TSB #</u>	<u>MODELS</u>	<u>SUBJECT/DESCRIPTION</u>
21-004-01 02/16/01	'01 (BR)	<p><i>Overdrive disabled to improve transmission reliability during cold temperature operation.</i></p> <p>This bulletin applies to vehicles equipped with an automatic transmission where the vehicle was built on or between June 26, 2000, and December 23, 2000, and the PCM software level is earlier (lower) than calibration 14 for model year 2001.</p> <p>Quality analysis has determined that insufficient lubrication of certain internal transmission components may occur when a vehicle is operated in temperatures lower than -20°C (-5°F). This condition may be caused by the automatic transmission fluid (ATF) freezing in the cooler lines and interrupting the flow of lubricating oil (ATF) to the transmission overdrive unit. This condition should be a concern only in areas where very cold ambient temperatures of -20°C (-5°F) are experienced.</p> <p>The revised software will not allow 4th gear overdrive to occur if ambient temperatures are less than -20°C (-5°F). The revised PCM software has been implemented to improve transmission reliability. The customer should be informed that reduced fuel economy would be expected when overdrive is not in use.</p> <p>The repair involves selectively erasing and reprogramming the Powertrain Control Module (PCM) with new software (calibration level 01Cal14).</p>
21-009-01 10/15/01	'01 (BE/BR)	<p><i>NV5600 Countershaft service.</i></p> <p>This bulletin involves Ram trucks manufactured prior to March 17, 2001, and equipped with the NV5600 6-speed, heavy duty transmission. Customers may experience a shifter vibration (commonly referred to as "gear clash") of the shift knob when shifting from one gear to another between 2500 and 3500 RPM after a cold start up. This condition is most evident when ambient temperatures are at or near 0°C (32°F) but can occur at warmer temperatures as well. The condition is most often reported on 3rd to 4th gear shifting, but can occur in the other shift ranges as well. The problem can be verified by assuring the transmission is at ambient temperature, vehicle moving and, with the engine at 2500 to 3500 RPM, shifting into and out of the gear ranges.</p> <p>This repair may include disassembly of the countershaft assembly, requiring the use of a 20-ton press. Attempts to use lesser equipment to effect this repair could result in damage or injury.</p> <p>If such a press is available, rebuilding the countershaft assembly is preferred. In the event a press is not available, a new countershaft assembly (PN 05073361AA) has been made available.</p> <p>Follow the service procedures in the appropriate service manual to complete necessary repairs. Follow normal warranty procedures to report the repairs.</p>

CATEGORY 21

TRANSMISSION

<u>TSB #</u>	<u>MODELS</u>	<u>SUBJECT/DESCRIPTION</u>
21-006-01 6/29/01	'94-'02 (BE/BR)	<p><i>Automatic transmission fluid usage ATF+4 (Type 9602).</i></p> <p>This information only bulletin supersedes technical service bulletin 21-16-99, dated October 22, 1999. The bulletin discusses a new transmission fluid (ATF+4 – Type 9602) which has been developed and is being used as factory fill for all vehicles with Chrysler automatic transmissions. Until now, vehicles originally filled with ATF+2 or ATF+3 were to be serviced with ATF+3. Effective immediately, it is recommended that all vehicles with Chrysler automatic transmissions except for 1999 and earlier minivans be serviced with ATF+4. ATF+3 should continue to be used for 1999 and earlier minivans because of the potential for torque converter shudder during break in. For all other applications the ATF+4 fluid offers significant benefits as outlined below.</p> <p>ATF+4 must always be used in vehicles that were originally filled with ATF+4.</p> <p>Service intervals do not change. The service interval currently in effect for a given vehicle should continue to be followed.</p> <p>ATF+4 is compatible with ATF+3 and can be used to top off vehicles that currently have ATF+2 or ATF+3. Do not use ATF+2 or ATF+3 to top off vehicles that have ATF+4 fluid.</p> <p>Benefits:</p> <ul style="list-style-type: none">• Better anti-wear properties• Improved rust/corrosion prevention• Controls oxidation• Eliminates deposits• Controls friction• Retains anti-foaming properties• Superior properties for low temperature operation <p>Mopar ATF+4 is a World Class Fluid having exceptional durability. However, the red dye used in ATF+4 is not permanent; as the fluid ages it may become darker or appear brown in color. ATF+4 also has a unique odor that may change with age. With ATF+4 fluid, color and odor are no longer indicators of fluid condition and do not support a fluid change.</p>

CATEGORY 22

WHEELS

<u>TSB #</u>	<u>MODELS</u>	<u>SUBJECT/DESCRIPTION</u>
21-004-01 02/16/01	'01 (BR)	<p><i>Chrome wheel care.</i></p> <p>Chrome wheels should be cleaned regularly with mild soap and water to maintain their luster and prevent corrosion. Wash them with the same soap solution as the body of the vehicle.</p> <p>To clean extremely dirty wheels care must be taken in the selection of tire and wheel cleaning chemicals and equipment to prevent damage to wheels. Only Mopar Wheel Treatment, p/n 05066247AB – 12 oz. Or 05066248AB – 5 gal., is recommended to remove brake dust, dirt, grease and grime. Any of the “DO NOT USE” items listed below can damage or stain wheels and wheel trim.</p> <p>DO NOT USE:</p> <ul style="list-style-type: none">• Any abrasive type cleaner• Any abrasive cleaning pad (such as steel wool) or abrasive brush• Any cleaner that contains an acid (this will immediately react with and discolor the chromium surface)• Any oven cleaner• Any abrasive metal cleaner.• Chrome polish unless it is buffed off immediately after application.• Any abrasive cleaning pad or brush• A car wash that has carbide tipped wheel-cleaning brushes.

CATEGORY 23**BODY**

<u>TSB #</u>	<u>MODELS</u>	<u>SUBJECT/DESCRIPTION</u>
23-027-01 9/21/01	'98-'02 (BR/BE) Equipped with 6x9 Mirrors Sales Code GPS or GPU	<i>Outside rearview mirror glass replacement.</i> This bulletin supersedes technical service bulletin 23-034-00 Rev. A, dated December 15, 2000. It is unnecessary to replace the entire outside rearview mirror assembly when the mirror glass is broken or is missing. Replacement mirror glasses are available from Mopar. Because of the extremely long list of part numbers involved, please consult the Mopar parts catalog for the correct part number(s).
23-034-01 11/30/01	'00-'01 (BR/BE)	<i>Scratching sound from the door seal while driving.</i> A scratching or itching type sound may be heard, coming from the front door opening. If a customer indicates that the condition is present, perform the repair procedure, which involves lubricating the secondary door seal with part number 04773427: Weather Seal Lubricant.

CATEGORY 25**EMISSIONS**

<u>TSB #</u>	<u>MODELS</u>	<u>SUBJECT/DESCRIPTION</u>
25-001-01 1/19/01	'01 (BR/BE)	<i>Generic Scan Tool May Not Display Certain DTC's and Erroneous LDP Switch.</i> This bulletin applies to vehicles with an RE automatic transmission built before January 12, 2001 (MDH 0112XX). A generic scan tool may not display certain Diagnostic Trouble Codes (DTC) when a Malfunction Indicator Lamp (MIL) illuminates. The PCM software must be updated to calibration level 0ICall4A.
25-002-01 1/19/01	'01 (BR/BE)	<i>Scan Tool Erroneously Displays P000 For DTC's P1740 And P0461.</i> This bulletin applies to vehicles with an RE automatic transmission built before January 31, 2001 (MDH 0131XX). A Generic Scan Tool or an Enhanced Scan Tool, like the DRB III, may erroneously display certain Diagnostic Trouble Codes (DTC) as P0000. As a result, the scan tool may display Freeze Frame data incorrectly. The PCM software must be updated to calibration level 0ICall4A.

TECHNICAL SERVICE BULLETINS ISSUED DURING 2003-2009

CATEGORY 2 FRONT SUSPENSION

<u>TSB #</u>	<u>MODELS</u>	<u>SUBJECT/DESCRIPTION</u>
02-003-02 6/17/02	'00-'02 (BR/BE)	<p><i>Toe-in specification change.</i></p> <p>This bulletin involves an update to the toe-in specification for front end alignments. The specification for toe-in has been revised to 0.2° ± 0.1° total toe in. This change has been shown to improve straight ahead driving performance and should be used whenever a front end alignment is performed.</p>
02-003-08 6/20/08	'08 (DM) 4500/5500	<p><i>Front and/or rear shock absorber noise.</i></p> <p>The customer may experience a clunking-like sound when traveling over small inputs (bumps and dips) in the road. This clunk-like sound is sometimes described as being similar to the sound that "loose lumber" may make when loose boards strike each other. This condition is more noticeable during cold ambient conditions below 40°F and at lower vehicle speeds when background noise is less. The sound may come from the front and/or rear shock absorbers.</p> <p>This condition is due to internal components within the vehicle shock absorber and the bulletin describes the replacement procedure.</p>

CATEGORY 3 AXLE/DRIVELINE

<u>TSB #</u>	<u>MODELS</u>	<u>SUBJECT/DESCRIPTION</u>
03-001-02 2/11/02	'02 (BR/BE)	<p><i>Front axle disconnect system.</i></p> <p>This bulletin involves a mid-2002 model year deletion of the front axle disconnect system on 2002 (BE/BR) 2500 and 3500 Ram Trucks. This change effects the front axle, transfer case and engine/headlamp and dash wiring harnesses. The bulletin applies to 2500 and 3500 (BE/BR) Ram trucks built after January 4, 2002 and equipped with front axles with the following part numbers: 52070136AO, 52070137AO, 52070138AP, and 52070139AO.</p> <p>The vehicles involved will retain Shift On the Fly (SFO) capability; however, with this change, the front driveshaft will now turn continuously when the vehicle is being driven. Due to the timing of this change this information is not reflected in the Service Manual and a future release will outline service procedures.</p>
03-002-02 7/1/02	'02-'03 (DR)	<p><i>Use of synthetic rear axle lubricant.</i></p> <p>This bulletin applies to 2002-2003 (DR) Ram trucks equipped with the 9-1/4" rear axle and trailer tow package. It is critical to optimum performance in trailer towing conditions that when service is being performed on the 9-1/4" rear axle on 2002-2003 (DR) Ram trucks, the axle must be refilled with Mopar 75W-140 synthetic gear and axle lubricant (PN 04874469). Five ounces (148ml) of Mopar friction modifier (PN 04318060AB) must also be added to vehicles equipped with the trac-lok style rear axle.</p>
03-003-04 6/15/04	'03-'04 (DR)	<p><i>Launch shudder.</i></p> <p>This bulletin involves adjusting the propeller shaft working angles and applies to vehicles equipped with a two-piece rear driveshaft. The problem is described as a drive line shudder or vibration while accelerating from a stop. The condition is most noticeable under heavy throttle acceleration and is usually present only at low speeds (below 25 mph). Vehicles equipped with a two-piece driveshaft are designed to minimize reaction forces that result from the universal joint transmitting torque at an angle. These forces cannot be eliminated entirely because of the necessity to compromise joint angle selection between curb and design loading conditions. U-joint angles change depending upon the amount of weight applied to the vehicle bed.</p> <p>Therefore U-joint angle readings may need to be taken with different vehicle loads in order to obtain a satisfactory compromise. The vehicle should be evaluated under the loaded condition that produces the objectionable disturbance.</p> <p>The repair procedure involves measurements at the transmission yoke, front propeller shaft, rear propeller shaft and rear axle. The working angles should be adjusted to provide the lowest angle possible for the output shaft to front propeller shaft, front propeller shaft to rear propeller shaft, and rear propeller shaft to axle pinion. The measurements will determine which direction to move the center bearing to optimize the angles. Install the appropriate bracket to obtain the minimum working angle, but still maintain at least ½ degree to ensure that there will be some movement in the U-joint bearings.</p>

CATEGORY 3**AXLE/DRIVELINE**

<u>TSB #</u>	<u>MODELS</u>	<u>SUBJECT/DESCRIPTION</u>
03-001-02 2/11/02	'03-'04 (DR)	<i>Axle whine.</i> This bulletin applies to 4x2, 2500 series, 140.5 inch wheelbase vehicles equipped with diesel engine, sales code ETC/ETH, and an automatic transmission, sales code DG8. The problem is that some vehicles may exhibit rear axle whine at speeds between 35 and 70 mph. The repair procedure involves identification of the pinion flange and propeller shaft that the vehicle is equipped with. If a repair is necessary, the propeller shaft is replaced using the chart listing the appropriate part numbers.

03-002-02 7/11/02	'02-'03 (DR)	<i>Axle-fluid level.</i> This bulletin supersedes TSB 03-001-04, revision A dated 5/11/04. The axle fill holes on some 2004 Dodge Truck axles may be located considerably higher than the actual fluid level. Filling the axle until the fluid comes out of the fill hole will overfill the axle, which could cause fluid foaming. When checking fluid level or filling a rear axle with fluid, you must measure distance from the bottom of the fill hole to the actual fluid level. This can easily be accomplished using a pipe cleaner or piece of wire. Make a 90 degree bend in the wire two inches from the end. The wire can then be inserted into the axle fill hole and used as a dipstick. Measure the distance from the bend to the oil level. The fluid levels for the axles are shown in the table below.
----------------------	--------------	---

Ram Truck 2500/3500

Axle	Fluid Level (measured from the bottom of the fill hole)	Fluid Capacity
10.5 Rear Axle	1 inch ± ¼ inch	85 oz. SAE 75W-90 Synthetic
11.5 Rear Axle	¼ inch ± ¼ inch	122 oz. SAE 75W-90 Synthetic
9-¼ Front Axle	¼ inch ± ¼ inch	76 oz. SAE 75W-90 Synthetic

Note: The limited slip feature on 2500/3500 series Ram Trucks utilizes the Trac Rite locking feature which does not require Trac-Lok additives or friction modifiers.

CATEGORY 6**CLUTCH**

<u>TSB #</u>	<u>MODELS</u>	<u>SUBJECT/DESCRIPTION</u>
06-001-03 5/16/03	'03 (BR)	<i>Rattle sound from transmission when idling.</i> This bulletin applies to vehicles equipped with a 5.9L Cummins high output Turbo Diesel (sales code ETH) and NV5600 six-speed manual transmission (sales code DEE) built on or before May 11, 2003. The vehicle operator may describe a rattle sound when idling in neutral with the clutch pedal released. The bulletin involves replacing the clutch disc with a revised part.

06-001-07 2/03/07	'07	<i>Clutch system may over-adjust causing difficulty engaging transmission gear.</i> This bulletin involves replacement of the clutch system flywheel, pressure plate, and disc. This bulletin applies to vehicles equipped with a 5.9 liter or 6.7 liter Cummins Turbo Diesel engine and the G56 manual transmission (sales code ETH, ETJ, and DEG respectively), and built on or before November 09, 2006. The customer may experience difficulty attempting to engage a manual transmission gear. This may be due to the self-adjusting mechanism in the clutch system. The self-adjusting clutch mechanism may over-adjust (forward adjust). This condition most often will occur within the first 1,000 miles of vehicle operation. The bulletin describes the proper repair technique to replace the flywheel, clutch plate, and clutch disc.
----------------------	-----	--

CATEGORY 8**ELECTRICAL**

<u>TSB #</u>	<u>MODELS</u>	<u>SUBJECT/DESCRIPTION</u>
08-016-02 9/2/02	'02-'03 (DR)	<i>Horn chirp and erroneous alarm.</i> This bulletin involves reprogramming the forward control module (FCM) should there be an erroneous horn chirp when a door is opened or an erroneous alarm. The correction is a reflash of the FCM.
08-004-03 3/14/03	'02-'03 (DR)	<i>Electro mechanical instrument cluster (MIC) erroneous indicator lamps.</i> Three conditions have been identified which may be caused by communication errors between the electro mechanical instrument cluster (MIC) and other electronic modules on the vehicle. 1. An intermittent false "Check Gauges" on diesel engine equipped vehicles. 2. An intermittent false chime and "Low Wash" indicator. 3. A "Trans Temp" indicator on a manual transmissions equipped vehicle. This bulletin involves selectively erasing and reprogramming the MIC with new software.
08/007/03 4/4/03	'03 (DR)	<i>Alternator mounting bracket cracked.</i> This bulletin applies to vehicles equipped with a 5.9L 24-valve diesel engine (sales codes ETC, or ETH) and built on or before February 13, 2003, with engine serial numbers prior to 57013271. The problem is that the vehicle operator may experience an accessory drive belt squeal during normal driving conditions. This bulletin describes how to replace the alternator support bracket with a revised bracket.
08-019-03 6/20/03	'03 (DR)	<i>Lamp-out indicator with aftermarket pickup box installation.</i> This information-only bulletin discusses situations where an aftermarket utility box is installed after the removal of the original equipment pickup box. Under the circumstances the lamp-out indicator may illuminate. This is due to the use of aftermarket rear stop and turn signal lamps which use a dual filament bulb instead of separate circuits for the stop and turn indicator. The bulletin then describes the reprogramming procedure to reset the lamp-out indicator.
08-031-03 10/31/03	'03 (DR)	<i>PCM connector corroded—sets MIL light.</i> This bulletin applies to vehicles equipped with a 5.9 liter diesel engine and an automatic transmission. Water may enter the PCM connector causing corrosion of electrical terminals on the PCM. This condition can set diagnostic trouble codes and illuminate the MIL light. If diagnostic trouble codes are present or other diagnostics lead to PCM connector problems, inspect the PCM and the PCM wire harness connector. The repair procedure involves replacement of the wiring harness.
08-011-04 3/16/04	'04 (DR)	<i>Poor radio sound quality with Infinity speakers.</i> This bulletin applies to vehicles equipped with Infinity speakers, sales code RCK. Radios equipped with Infinity Speakers may exhibit a variety of symptoms due to reversed right front speaker wiring (polarity). Symptoms include: front door or speaker buzz, poor sound quality, lack of bass. The solution involves correcting speaker wiring polarity in the radio connector.
08-014-04 3/30/04	'04 (DR)	<i>Radio intermittent audio.</i> This bulletin applies to vehicles equipped with an AM/FM/cassette radio built prior to January 30, 2004 or AM/FM/CD radio built prior to January 30, 2004. Radios built after 1/30/04 will no longer have vent holes in the area the repair procedure covers. If the audio drops out when the vehicle is moved from a cold to a warm or humid environment, the reason is that condensation builds up across the audio amplifier circuitry, causing the amplifier to shut down. Typically, cycling the ignition switch off and on will restore the audio output. If the problem persists, the correct repair procedure is to apply tape over the row of slots on the left hand side of the radio's top cover.

CATEGORY 8**ELECTRICAL**

<u>TSB #</u>	<u>MODELS</u>	<u>SUBJECT/DESCRIPTION</u>
08-016-02 9/2/02	'02-'03 (DR)	<p><i>Mopar accessory remote starter inoperative due to hood switch.</i></p> <p>This bulletin applies to vehicles equipped with a Mopar remote starter kit. The problem frequently occurs as one or more of the following:</p> <ul style="list-style-type: none">• When the transmitter is pressed twice for start, the vehicle horn will chirp once but the vehicle engine will not start.• When the transmitter is pressed twice for start, the vehicle horn will chirp twice, indicating a problem with the remote start system and the vehicle engine will not start.• When the transmitter is pressed twice for start, the vehicle will chirp once, the engine will start and then turn off. <p>The technician may not be able to verify the symptom(s) because it may be an intermittent condition. The corrective action involves replacing the hood switch for the remote starting system.</p>
08-024-05 5/4/05	'02-'06 (DR)	<p><i>Radio communication equipment installation recommendations.</i></p> <p>This information only bulletin gives the dealership technician some guidelines for the installation of two-way radio equipment.</p>
08-058-05 10/29/05	'05-'06 (DR)	<p><i>Revised radio antenna mast installation procedure.</i></p> <p>This information only bulletin advises the proper tightening torque (30-32 in-lbs) for the radio antenna mast for various Chrysler group products.</p>
08-014-06 3/16/06	'06 (DR)	<p><i>UConnect Hands Free module fails to respond due to module lock-up.</i></p> <p>This bulletin supersedes service bulletin 08-049-05 dated September 1, 2005, and applies to vehicles equipped with UConnect Hands Free Communications (sales code RSP) that were built prior to October 2, 2005. If the UConnect Hands Free Communications system does not respond when system activation is attempted by the customer, the technical service bulletin gives the technician the proper repair technique to reset the hands-free module.</p>
08-016-06 Rev. A 7/18/06	'06-'07 (DR)	<p><i>Intermittent operation of electrical components due to ignition off draw (IOD) fuse not being fully seated.</i></p> <p>This bulletin supersedes technical service bulletin 08-016-06, dated March 22, 2006. The ignition off draw (IOD) fuse is used to prevent battery discharge during shipping and long term storage of vehicles. If the fuse is not completely inserted, partial contact of the fuse terminals could occur. When the vehicle is prepped for customer delivery, ensure that the fuse is fully engaged. When the IOD fuse holder is depressed into the carrier, an initial distinct detent will be felt to overcome the "pre-hold position." On '06 and '07 DR vehicles the circuits fed by the IOD fuse are: Radio, EVIC, Wireless Control Module, Hands Free Module, Satellite Radio, Video Screen, CCN wake-up with ignition off, Underhood Lamp, and CCN Interior Lighting.</p>
08-020-06 5/5/06	'06 (DR)	<p><i>Overhead console average fuel economy display.</i></p> <p>This information-only bulletin discusses the calculation method used by the truck's average fuel economy display. On '06 vehicles, the calculation has been changed to use the last displayed average fuel economy as a starting point for the calculation after a reset. The average fuel economy will then be adjusted from that point. If the display read 21.6 mpg at the time the reset was activated, the new display will start at 21.6 mpg and would change from that point depending on the current fuel usage. This was done to eliminate the extreme variations caused by very high or low fuel usage at the time of the reset.</p>

CATEGORY 8**ELECTRICAL**

<u>TSB #</u>	<u>MODELS</u>	<u>SUBJECT/DESCRIPTION</u>
08-016-02 9/2/02	'02-'03 (DR)	<p><i>TIPM Flash: DTC's indicating short circuits in the wiring on the trailer or no engine crank with DTC P1277 – starter control circuit too low.</i></p> <p>This bulletin supersedes technical service bulletin 08-021-06, dated May 10, 2006.</p> <p>This bulletin involves a discussion and reprogramming of the totally integrated power module (TIPM). This bulletin applies to vehicles built prior to April 03, 2006.</p> <p>The customer may experience any of the following TIPM diagnostic trouble codes (DTC's):</p> <p>B166B - Left Trailer Tow Lamp Control Circuit Low. Trailer harness left lamp circuit is shorted to ground.</p> <p>B166C - Left Trailer Tow Lamp Control Circuit High. Trailer harness left lamp circuit is shorted to battery voltage.</p> <p>B178C - Left Trailer Tow Lamp Control Circuit Over Current. Trailer harness left lamp circuit is intermittently grounding.</p> <p>B166F - Right Trailer Tow Lamp Control Circuit Low. Trailer harness right lamp circuit is shorted to ground.</p> <p>B1670 - Right Trailer Tow Lamp Control Circuit High. Trailer harness right lamp circuit is shorted to battery voltage.</p> <p>B166E - Right Trailer Tow Lamp Control Circuit Over Current. Trailer harness right lamp circuit is intermittently grounding.</p> <p>B1667 - Back Up Lamp Feed Low. Trailer harness back up circuit is shorted to ground.</p> <p>B2215 - Front Control Module Internal (TIPM). An internal fault code counter has exceeded its limit of 250 counts and one or more electrical outputs controlled by the TOPM have been disabled.</p> <p>P1277 - Starter Control Circuit 2 Low (TIPM). The output feed current to the starter solenoid has exceeded the upper current limit of 75 amps. This may result in a no-crank condition.</p> <p>DTC's B1667, B166B, B166E, B166F, B178C and B2215: These DTC's indicate that a (hard or intermittent) short circuit to ground exists in the wiring of one or more of the trailer electrical harness circuits. The TIPM retries the output on each ignition cycle or request (brake or turn signal activation) in an attempt to enable the output in case the fault is intermittent. The new TIPM software raises the TIPM circuit trigger point from 15 amps to 20 amps.</p> <p>DTC's B166C and B1670: These DTC's indicate that a short circuit to battery voltage (12 volts) exists in the wiring of one of the trailer electrical harness circuits.</p> <p>DTC B2215 - Front Control Module (TIPM): This fault code occurs when the TIPM detects a short (to ground or to battery) on one of the trailer circuits more than 250 times. When B2215 is present with one of the above trailer circuit faults, the TIPM will turn off (disable) the respective faulty trailer circuit or circuits. This internal fault does not mean that the TIPM module is defective. The TIPM memory can be cleared, and this action will turn on a previously disabled trailer circuit. If possible, the fault in the circuit should be repaired first before clearing the TIPM memory. The dealer will need a scan tool to clear the TIPM memory.</p> <p>DTC P1277 - Starter Control Circuit too Low (TIPM): The TIPM monitors the output current to the starter solenoid for over-current conditions. The DTC is set when the output current to starter solenoid exceeds 75 amps. On trucks equipped with a diesel engine, there may be times in cold climates when it is normal for the starter solenoid current to exceed 75 amps. The new TIPM software raises the TIPM current trigger point for DTC P1277 from 75 amps to 100 amps.</p> <p>If any of the DTC's listed above are present, perform the repair procedure.</p>
08-026-06 Rev. A 10/25/06	'06 (DR/DH/D1)	<p><i>Overhead console temperature reading inaccurate or dome lamp turns off too soon.</i></p> <p>This bulletin supersedes technical service bulletin 08-026-06, dated June 02, 2006.</p> <p>This bulletin involves selectively erasing and reprogramming the cabin compartment node (CCN) with new software. This bulletin applies to vehicles built on or before May 30, 2006. The vehicle owner may notice that if a vehicle door is left open for longer than 20 seconds the illuminated interior (dome) lamps will turn off. Or the vehicle operator may report that the ambient temperature first displayed in the overhead console is not accurate (displays -40°C or -40°F), when the ignition switch is turned to the "On" position, then slowly updates to the outside ambient temperature as the vehicle is driven. If the vehicle operator describes or experiences the symptom/condition, perform the repair procedure which involves a reflash to the CCN.</p>

CATEGORY 8**ELECTRICAL**

<u>TSB #</u>	<u>MODELS</u>	<u>SUBJECT/DESCRIPTION</u>
08-044-06 10/07/06	'07 (DR)	<i>Steering angle sensor over travel performance (DTC:C1240).</i> This bulletin involves the diagnosis and possible replacement of the steering angle sensor. This bulletin applies to vehicles equipped with the Electronic Stability Program (sales code BNB) and built prior to October 03, 2006. The customer may experience an illumination on the instrument cluster of the ABS (anti-Lock Brake System) and/or the ESP/BAS (Electronic Stability Program/Brake Assist System) warning lights. Investigation may reveal the presence of diagnostic trouble code (DTC) C1240 – Steering Angle Sensor Over Travel Performance. If the diagnostic test procedure for DTC C1240 determines that the steering angle sensor is at fault, then perform the repair procedure.
08-046-06 10/25/06	'04-'07	<i>Cell phone induced buzz or clicking-like sound in radio speakers.</i> This bulletin involves a discussion regarding cell phone generated signal interference with the vehicle radio system. A customer may experience a buzzing or clicking-like sound coming from the vehicle radio speaker(s). The sound may be heard when the radio is in AM or FM mode. The clicking-like sound may sound like Morse code. This information-only bulletin points out that the construction of certain cell phones may generate frequencies that can interfere with the vehicle radio system. These frequencies may result in buzzing and/or clicking-like sounds in the vehicle radio. This condition can be easily corrected by instructing the customer to move their cell phone away from the immediate area around vehicle radio system (radio, radio amplifier, antenna, antenna lead). Do not replace any radio system component in an attempt to address this condition.
08-003-07 01/27/07	'0 (DR/DH/D1/DC)	<i>7 Remote start system – Diagnostic chart for antenna.</i> This bulletin involves a diagnostic chart that may be used to aid the technician with the diagnosis of the antenna on an originally equipped (factory installed) remote start system. This bulletin applies to vehicles with an original equipment remote start system (sales code XBM). The customer may notice that the signal range of the remote keyless entry system is reduced (less than 100 feet). This condition may be due to the RKE antenna. The diagnostic flow chart is provided as a diagnostic aid for dealer technicians.
08-015-07 06/06/07	'06-'07 (DR)	<i>Flash: Sunroof module, excessive ignition off draw, pop in radio with ignition off, dome lamp flickers and may not go off.</i> This bulletin involves selectively erasing and reprogramming the Sunroof Motor Module with new software.
08-018-07 06/23/07	'0 (DR/DH/D1/DC)	<i>7 MOPAR remote start system – RKE – intermittent operation or alarm may sound.</i> This bulletin involves the installation of a Mopar remote start system service repair kit.
08-007-08 REV. A 7/4/08	'07-'08	<i>Engine does not crank or start due to electronic lockup of the remote key module.</i> This bulletin applies to vehicles built on or before May 05, 2008. The customer may experience a no engine crank and a no engine start condition. Also, the remote keyless entry system will not operate. This condition may be due to an electrostatic discharge from the ignition key into the wireless control module (WCM), causing the WCM to electronically lock up. This condition is corrected by the replacement of the WCM (also known as the Sentry Key Remote Entry Module).
08-028-08 9/18/08	'0 (DR/DH/DC/D1)	<i>8 Voice recognition screen lock-up on REN or REZ radio equipped with hands-free communications.</i> The customer may experience one of the following conditions: a) A "lock up" condition of the radio screen when the voice recognition (VR) button is pressed b) When the VR button is pressed, the radio display changes to the phone screen and there is a lack of the "Ready" audio prompt. If the above symptom/condition is experienced, the HFM is replaced. This bulletin applies to radios built before 11/6/07.
08-035-08 11/21/08	'07-'09 (DH/D1)	<i>Proper testing tools for oxygen sensor terminals.</i> This bulletin describes the use of proper test probes to test the oxygen (O2) sensor connector terminals equipped with the new TP2 style sensor. The recommended tool for these testing procedures is the Miller Tool #6801.

CATEGORY 9**ENGINE**

<u>TSB #</u>	<u>MODELS</u>	<u>SUBJECT/DESCRIPTION</u>
09-002-02 3/11/02	'98-'02 (BR)	<p><i>Crankcase breather overflow.</i></p> <p>This bulletin applies to 1998-2002 (BR) Ram trucks equipped with the 24-valve Cummins diesel engine built after March 27, 1998 (engine serial number 56443872). Owners of these vehicles may experience engine oil overflow from the front crankcase breather when the vehicle is operated off-road on an extreme downhill grade (37.5% or 22° slope/grade). Operation of this type for extended periods of time can cause enough engine oil depletion to damage the engine. A kit containing all components necessary to eliminate the oil overflow has been made available. If the condition exists, perform the repair procedure outlined in this bulletin. The repair involves the addition of a new breather kit.</p>
09-008-02 10/21/02	'98-'02 (BR/BE)	<p><i>Engine knock or rattle sound when climbing a long grade and towing a heavy trailer.</i></p> <p>This bulletin applies to 1998-2002 Ram trucks equipped with the 24-valve Cummins diesel engine (sales code ETC or ETH). Owners may experience an engine knock or rattle sound when climbing a long grade while towing a heavy trailer. If the condition exists, replace the engine thermostat as outlined in the service manual. Note: Mopar 05015708AC is to be used exclusively for this service bulletin. Use thermostat 05015708AB for all other 24-valve Cummins thermostat repairs.</p>
09-004-06 03/31/06	'03-'06 (DR)	<p><i>Accessory drive belt chirp at shutdown.</i></p> <p>This bulletin applies to vehicles with diesel engine sales code ETH. A chirping sound may be heard coming from the accessory drive belt when the engine is shut down. If a customer indicates that the condition is present, the bulletin directs the technician to install an overrunning clutch pulley on the generator.</p>
08-015-07 06/06/07	'06-'07 (DR)	<p><i>MIL illumination due to DTC P2262 - Revised diagnosis and repair procedures.</i></p> <p>This bulletin applies to vehicle equipped with a Cummins 6.7-liter engine (sales code ETJ). The bulletin supersedes technical service bulletin 09-002-09 dated 5/2/09. This bulletin discusses revised diagnostic and repair procedures for DTC P2262 - Turbocharger Boost Pressure Not Detected - Mechanical. Recent PCM calibration updates have improved the robustness to this DTC through updated diagnostic strategies. As a result, many events which have no adverse affects on drivability, emissions, or reliability will no longer set the P2262 fault.</p> <p>As a result of recent PCM calibration updates, the proper repair for <i>some</i> P2262 faults is merely to update the calibration, while others will require cleaning or replacing the turbocharger. Scan Tool software includes a P2262 diagnosis test for this purpose. The new P2262 diagnosis test must be used <i>prior</i> to performing any of the following:</p> <ul style="list-style-type: none">• Clearing codes• Updating the PCM• Beginning the turbocharger repair. <p>Based on the outcome of the P2262 diagnosis test, the Scan Tool will provide one of the following as the proper direction for the appropriate repair. Service info and complete the repair as directed:</p> <ul style="list-style-type: none">• Update PCM flash calibration to the latest calibration. No repair required to the turbocharger.• Clean the turbocharger.• Update PCM flash calibration to the latest calibration and clean the turbocharger.• Replace the turbocharger.• Update PCM flash calibration to the latest calibration and replace the turbocharger.

CATEGORY 11**EXHAUST**

<u>TSB #</u>	<u>MODELS</u>	<u>SUBJECT/DESCRIPTION</u>
11-002-07 9/25/07	'07-'08 (DH/D1) 2500/3500	<p><i>Inspection and test procedures for the 6.7-liter diesel particulate filter (DPF).</i></p> <p>This bulletin applies to vehicle equipped with a Cummins 6.7-liter engines (sales code ETF). The customer may experience a malfunction indicator lamp (MIL) illumination, warning chime, and an overhead electronic vehicle information center (EVIC) message that states "Catalyst Full Service Required." Investigation may reveal that the MIL illumination is due to one or more of the following diagnostic trouble codes (DTCs):</p> <p>P1451 – Diesel Particulate Filter System Performance. P2463 – Diesel Particulate Filter – Soot Accumulation. P242F – Diesel Particulate Filter Restriction – Ash Accumulation.</p> <p>The balance of the 10-page bulletin describes the inspection, test, repair, or replacement of the DPF based on the severity of the accumulation in the DPF.</p>
11-001-08 5/21/08	'07-'08 (DH/D1) 2500/3500	<p><i>Cleaning the turbocharger on the Cummins 6.7-liter engine.</i></p> <p>This 17-page bulletin describes the process of cleaning the turbocharger using Cummins Engine Update Kit 10138-UPD to address excess soot accumulation. The procedure cleans the internal components on the exhaust side of the turbocharger.</p> <p>The bulletin goes hand-in-hand with TSBs 11-005-08 and 11-002-07 for detailed turbocharger, engine and exhaust aftertreatment system repair procedures.</p>
11-002-08 5/21/08	'07-'08 (DH/D1) 2500/3500	<p><i>Inspections and test for the turbocharger on the Cummins 6.7-liter engine.</i></p> <p>The customer may experience a malfunction indicator lamp (MIL) illumination due to diagnostic trouble code (DTC): P2262 – Turbocharger Boost Pressure Not Detected – Mechanical.</p> <p>If further codes of P1451, P2463 or P242F are present, the technician is referred to the repair procedure listed in TSB 11-002-07. If the codes are not present, the repair and cleaning procedures in this 8-page bulletin and TSB 11-001-08 are to be performed.</p>
11-001-09 7/23/09	'07-'09 (DH/D1)	<p><i>Diesel Particulate Filter: Diagnosis and repair of DTC's P1451, P200C, P242F or black smoke from exhaust.</i></p> <p>This bulletin applies to vehicles equipped with a Cummins 6.7-liter engine (sales code ETJ). The customer may experience a malfunction indicator lamp (MIL) illumination, warning chime and an overhead electronic vehicle information center (EVIC) message regarding the aftertreatment system and/or black smoke from the exhaust and/or a no start condition. Further investigation by the technician may reveal that the MIL illumination and/or EVIC message is due to one or more of the following diagnostic trouble codes (DTC's):</p> <p>P1451 - Diesel Particulate Filter - System Performance P242F - Diesel Particulate Filter Restriction - Ash Accumulation P200C - Diesel Particulate Filter Over Temperature - Bank 1.</p> <p>This bulletin provides revised diagnostic and repair procedures for DTC's P1451, P200C, P242F, black smoke from the exhaust, or a no start condition due to a nonfunctional or plugged diesel particulate filter (DPF).</p>
11-002-09 8/5/09	'07-'09 (D1/DH)	<p><i>Diesel particulate filter Stationary DeSoot.</i></p> <p>This bulletin applies to D1/DH vehicles equipped with a 6.7-liter Cummins diesel engine (sales code ETJ). Mobile DeSoot still applies to DC/DM vehicles equipped with the 6.7-liter Cummins diesel engine (sales code ETJ). Stationary DeSoot has replaced Mobile DeSoot as the repair for Diagnostic Trouble Codes P1451 and P2463. This bulletin provides the procedure to perform Stationary DeSoot. This new procedure allows running the DeSoot in a secured area with the vehicle unattended.</p> <p>Stationary DeSoot can only be performed when the diesel particulate filter has exceeded a specified soot threshold. The Diagnostic Scan Tool will not allow the procedure to operate unless the threshold has been exceeded. If the vehicle does not have an active P1451, the soot in the Diesel Particulate Filter is at a normal level and a scan tool initiated DeSoot is not needed.</p>

CATEGORY 13 FRAME & BUMPERS

<u>TSB #</u>	<u>MODELS</u>	<u>SUBJECT/DESCRIPTION</u>
13-001-03 2/7/03	'03 (DR)	<p><i>Frame alterations.</i></p> <p>This bulletin is to support the 2003 Body Builder's Guide and presents guidelines that must be followed during modifications or alterations to any 2003 Dodge Ram pickup frame. The following general industry standard procedures are recommended for proper installation of special bodies and/or equipment on the Ram pickup frame, such as fifth-wheel hitches, snow plows, etc. Failure to follow these recommendations could result in damage to the basic vehicle and possible injury to occupants. The information only bulletin gives the guidelines for welding and drilling of holes into the frame.</p>

CATEGORY 14 FUEL

<u>TSB #</u>	<u>MODELS</u>	<u>SUBJECT/DESCRIPTION</u>																					
23-018-02 5/20/02	'00-'01 (BR/BE)	<p><i>Fuel cap difficult to remove.</i></p> <p>This bulletin involves installing a revised fuel cap.</p>																					
14-002-02 Rev. A 6/13/03	'98-'02 (BE/BR)	<p><i>Tampering with VP44 fuel pump on Cummins diesel engine.</i></p> <p>This bulletin supersedes technical service bulletin 14-002-02, dated July 1, 2002. A number of the VP44 fuel pumps have been returned through the warranty process as a result of tampering. Generally, the customer complains that the vehicle dies while driving. When diagnosed, there may or may not be Diagnostic Trouble Codes (DTC) present. When DTCs are present, there may be one or more of the following:</p> <table border="1"><thead><tr><th><u>DTC</u></th><th><u>P Code</u></th><th><u>Description</u></th></tr></thead><tbody><tr><td>124</td><td>P 0234</td><td>Turbo boost limit exceeded.</td></tr><tr><td>146</td><td>P 0217</td><td>Decreased engine performance due to engine overheat condition.</td></tr><tr><td>361</td><td>P 0254</td><td>Fuel injection pump fuel valve current too high.</td></tr><tr><td>363</td><td>P 0251</td><td>Fuel injection pump mechanical failure fuel valve feedback circuit.</td></tr><tr><td>364</td><td>P 1689</td><td>No communication between ECM and injector pump module.</td></tr><tr><td>375</td><td>P 0602</td><td>ECM fuel calibration error.</td></tr></tbody></table> <p>The diagrams show the area where performance enhancing equipment is being connected into the outboard wire of the two wires that control operation of the metering solenoid in the pump. Another type of device places a connector between the metering solenoid harness and the upper connector on the pump. Telltale evidence can be seizure of the pump rotor, and/or cracked or overstressed pump cam ring. The protective sleeve around the two wires may be rolled or cut back to gain access for connection. Injection pumps that have been tampered with are not warrantable.</p>	<u>DTC</u>	<u>P Code</u>	<u>Description</u>	124	P 0234	Turbo boost limit exceeded.	146	P 0217	Decreased engine performance due to engine overheat condition.	361	P 0254	Fuel injection pump fuel valve current too high.	363	P 0251	Fuel injection pump mechanical failure fuel valve feedback circuit.	364	P 1689	No communication between ECM and injector pump module.	375	P 0602	ECM fuel calibration error.
<u>DTC</u>	<u>P Code</u>	<u>Description</u>																					
124	P 0234	Turbo boost limit exceeded.																					
146	P 0217	Decreased engine performance due to engine overheat condition.																					
361	P 0254	Fuel injection pump fuel valve current too high.																					
363	P 0251	Fuel injection pump mechanical failure fuel valve feedback circuit.																					
364	P 1689	No communication between ECM and injector pump module.																					
375	P 0602	ECM fuel calibration error.																					
14-005-02 11/8/02	'03 (DR)	<p><i>Fuel filter/water separator drain valve restriction.</i></p> <p>This bulletin applies to vehicles equipped with a 5.9L Cummins 24-valve diesel engine (sales code ETC or ETH), built before October 11, 2002. The problem described is that when the fuel filter/water separator drain valve is opened, nothing comes out. The bulletin outlines the procedure for purging fluid out of the filter.</p>																					
14-004-05	'03-'05 (DR)	<p><i>Electronic fuel control (EFC) actuator available for service</i></p> <p>This bulletin deals specifically with an engine surge at idle condition. The diagnostic procedures are the same as those listed in TSB 14-003-05. The bulletin describes the repair procedure for replacement of the electronic fuel control actuator.</p>																					
14-003-06 Rev. A 10/27/06	'03-'07 (DR/DH/D1/DC)	<p><i>Cummins diesel diagnostics.</i></p> <p>This bulletin applies to vehicles with the 5.9 liter engine, sales code ETH or ETC. Revised diagnostic procedures are available for the following conditions:</p> <ul style="list-style-type: none">• Engine cranks for a long time or will not start• White smoke and/or misfire after starting when the engine temperature is below 150° F• Engine surges at idle• Engine sounds <p>The 12-page bulletin gives the service technician a set of revised diagnostic procedures for the fuel system. Each condition is discussed and possible causes are established. Step-by-step instructions help the technician identify and repair the problem.</p>																					

CATEGORY 14**FUEL**

<u>TSB #</u>	<u>MODELS</u>	<u>SUBJECT/DESCRIPTION</u>
14-005-06 07/27/06	'06-'07 (DH/D1/DC)	<p><i>5.9-liter and 6.7-liter Cummins diesel engines - correct low and ultra-low sulfur highway diesel fuel use.</i></p> <p>This bulletin involves a discussion regarding the correct diesel fuel to use for either the 5.9-liter or the 6.7-liter Cummins diesel engine (sales code ETH and ETJ respectively).</p> <p>Dodge Ram trucks equipped with the 6.7L Cummins Turbo-Diesel engine are required by Federal law to be fueled with ultra-low sulfur diesel fuel (model year '07.5). Early production 2007 Dodge Ram trucks equipped with the 5.9 Cummins Turbo Diesel engine are allowed by Federal law to be fueled with low sulfur diesel fuel, and are encouraged to fuel with ultra-low sulfur diesel fuel. The new ultra-low sulfur highway diesel fuel enables vehicles equipped with the advanced emissions control devices to achieve more stringent U/S EPA vehicle emissions standards.</p>
14-007-06 Rev. A 09/02/06	'06-'07 (DH/D1/DC)	<p><i>Fuel and fuel filtering requirements for Cummins 5.9-liter and 6.7-liter engines.</i></p> <p>This bulletin supersedes technical service bulletin 14-007-06, dated August 25, 2006.</p> <p>This information-only bulletin involves a discussion regarding fuel system requirements. The bulletin applies to vehicles equipped with a 5.9-liter High Output or a 6.7-liter Cummins Turbo Diesel engine (sales codes ETH or ETJ respectively) that were built on or after March 07, 2006. Bulletin highlights follow:</p> <p>For the diesel engine system to operate at its peak performance a high level of fuel quality must be maintained. Emission control and fuel delivery systems have advanced significantly. Care must be taken to ensure that the fuel that is delivered to the engine fuel injection system is of the highest quality possible and free of contaminants.</p> <p>Significant components to fuel quality are: the initial quality of the fuel (as dispensed from the service station fuel pump or bulk storage), on-vehicle fuel storage, and the on-vehicle fuel filtering of the diesel fuel prior to the fuel injection process.</p> <p>Use good quality diesel fuel from a reputable supplier. It is recommended that purchase of diesel fuel be made from a service station that is known to dispense a high volume of highway diesel fuel.</p> <p>Ultra low sulfur highway diesel fuel is required for use in Dodge Ram trucks equipped with a 6.7-liter diesel engine.</p> <p>A maximum blend of 5% biodiesel (B5) is acceptable as long as the biodiesel mixture meets ASTM specification D-975, D-975-grade S-15, and ASTM D6751. A biodiesel fuel blend that is higher than 5% is not acceptable without additional fuel processing because these higher percentage biodiesel blends contain excess amounts of moisture which exceed the water stripping capability of the on-engine final fuel filter. Should a higher percentage biodiesel fuel be used, an auxiliary water stripping filter will be required.</p> <p>A maximum blend of 20% biodiesel (B20) can be used by government, military, and commercial fleets who equip their vehicle(s) with an optional water separator, and adhere to the guidelines in the <i>Department of Defense specification A-A-59693</i>.</p> <p>Fuel conditioners (additives) are not recommended and should not be required if you buy good quality fuel and follow cold weather advice supplied in the Owner's Manual.</p>

CATEGORY 18**VEHICLE PERFORMANCE**

<u>TSB #</u>	<u>MODELS</u>	<u>SUBJECT/DESCRIPTION</u>
18-024-02 8/12/02	'03 (DR)	<p><i>Incorrect dual wheel identification in VIN, may effect replacement powertrain control module (PCM) programming.</i></p> <p>The sixth character in the VIN is used to identify the vehicle series (1500, 2500, 3500). Some 2003 vehicles equipped with dual rear wheels, built prior to July 15, 2003, may have an incorrect number as the sixth character of the VIN. All vehicles equipped with dual wheels, sales code WLA, should have the number "4" as the sixth character. This identifies the vehicle as a 3500 series equipped with dual rear wheels. The incorrectly built vehicles will have the number "3" in that position. In the event that a Powertrain Control Module (PCM) would require replacement, the new module requires that the complete VIN be input during the programming procedure. If a new PCM is programmed with a "3" as the sixth character and it is equipped with dual rear wheels, a conflict is likely to occur with the ABS module which will set an error code. Dual rear wheel equipped vehicles require an ABS module calibrated for dual rear wheels. If PCM replacement is ever required, simply input a "4" instead of the "3" as the sixth character in the VIN when programming the PCM.</p>
18-015-03 4/4/03	'03 (DR)	<p><i>Powertrain control module (PCM) shift quality improvements</i></p> <p>The bulletin applies to vehicles equipped with a 5.9L standard output Cummins diesel engine(sales code ETC) and a 47RE transmission(sales code DGP) built before December 31, 2002. The vehicle operator may find that the vehicle will not shift out of third gear at throttle between 50% and 90% until 70 mph. The repair involves selectively erasing and reprogramming the powertrain control module (PCM) with new software.</p>
18-027-03 7/4/03	'03 (DR)	<p><i>No throttle response, lack of power while towing and diagnostic trouble codes (DTC) P2638/P0700.</i></p> <p>The bulletin applies to vehicles equipped with a Cummins diesel engine (sales code ETC or ETH) built on or before July 25, 2003. The vehicle may exhibit:</p> <ul style="list-style-type: none">• No throttle response if the engine is started with the Accelerator Pedal Position Sensor (APPS) in an off-idle position (pedal depressed) and the transmission is shifted into drive or reverse while the APPS remains in an off-idle position (pedal depressed), causing the engine to remain at idle.• Lack of power while towing or hauling a heavy load with the transmission in overdrive – vehicles equipped with 47RE transmission. <p>The repair involves selectively erasing and reprogramming the Cummins CM845 engine control module (ECM) with new software.</p>
18-030-03 8/29/03	'98.5-'02 (BE/BR) '03-'04 (DR)	<p><i>Generic Cummins engine control module (ECM) procedure.</i></p> <p>This bulletin applies to Ram trucks equipped with the 5.9L Cummins 24-valve diesel engine (sales code ETC or ETH). Mopar is phasing out pre-programmed Cummins Diesel engine control modules (ECM). New modules will no longer be pre-programmed when received from Mopar. Replacement of future ECM's will require programming utilizing the DRBIII and TechCONNECT.</p>
18-003-04 2/3/04	'03-'04 (DR)	<p><i>Poor A/C performance, slow fuel gauge response, and diagnostic trouble codes PO341 and P1757.</i></p> <p>This bulletin applies to vehicles equipped with a Cummins Turbo Diesel engine (sales code ETC or ETH) with an engine serial number 57130284 or earlier and the engine date of manufacture on or before December 10, 2003. The owner of the vehicle may describe slow fuel gauge response after adding fuel. On California emission equipped vehicles, the problem is rapid A/C clutch cycling and poor A/C performance until coolant temperature reaches 170°. The repair involves erasing and reprogramming the Cummins ECM with new software.</p>
18-004-04 2/3/04	'04 (DR)	<p><i>Poor cab heat and/or slow engine warm-up in cold ambient temperatures.</i></p> <p>This bulletin applies to DR vehicles equipped with a Cummins Turbo Diesel engine (sales code ETC or ETH) and an automatic transmission, with an engine serial number 57130284 or earlier and the engine date of manufacture on or before December 10, 2003. The vehicle operator may describe poor cab heat and/or slow engine warm-up in cold ambient temperatures. A new feature has been added that allows the vehicle operator to use the speed control switches to increase the engine speed up to 1500 rpm in order to improve cab heat. The feature must be enabled using the DRBIII. If the vehicle operator would like to have the feature enabled, perform the repair procedure which involves erasing and reprogramming the Cummins ECM with new software.</p>

CATEGORY 18**VEHICLE PERFORMANCE**

TSB #	MODELS	SUBJECT/DESCRIPTION
18-007-04 2/24/04	'04 (DR)	<p><i>White smoke, engine stumble/misfire, or flat spot in engine performance.</i></p> <p>This bulletin applies to vehicles equipped with a Cummins Turbo Diesel engine (sales code ETH) with an engine serial number 57130285 through and including 57149668 and the engine date of manufacture 12/10/2003 through and including 2/2/2004. The vehicle operator may describe:</p> <ul style="list-style-type: none"> • White smoke during no-load engine acceleration between 2800 and 3000 rpm. • Engine stumble/misfire or flat spot during moderate accelerations between 1500 and 2500 rpm. May be accompanied by white smoke. • During cold ambient temperatures (30° or below) white smoke and/or engine stumble when engine is started after an extended cold soak. • During cold ambient temperatures (30° or below) white smoke when restarting engine that has not yet reached normal operating temperature. <p>If the vehicle operator describes or the technician experiences the problem, perform the repair procedure which involves erasing and reprogramming the Cummins ECM with new software.</p>
18-033-04 8/20/04	'98.5 - '02 (BR) '03 - '05 (DR)	<p><i>Cummins engine control module (ECM) procedure.</i></p> <p>Mopar is phasing out pre-programmed Cummins diesel engine control modules (ECM). New modules will no longer be pre-programmed when received from Mopar. Replacement of future ECM's will require programming at the dealership. This bulletin describes the programming procedure.</p>
18-041-05 12/20/05	'06	<p><i>Flash: engine performance/white smoke.</i></p> <p>This bulletin applies to Ram trucks equipped with the 5.9L Cummins 24-valve diesel engine (sales code ETH) built on or after June 9, 2005, through and including November 8, 2005. This bulletin involves programming the PCM (Cummins) with new software. The software is designed to reduce white smoke and improve engine performance after a cold start at ambient temperatures below 60°F and to improve oil pressure gauge operation.</p>
18-030-03 8/29/03	'06-'07 (DR, DH, D1) '07 (DC)	<p><i>StarSCAN StarMOBILE abort recovery procedures.</i></p> <p>This information-only bulletin supersedes technical service bulletin 18-001-06, dated January 11, 2006, and provides guidelines to minimize flash reprogramming problems and recovery procedure information for failed flash attempts.</p>
18-003-06 Rev. A 09/27/06	'05-'06 (DH, D1)	<p><i>Flash: long crank when starting and/or transmission shift and battery charging enhancements.</i></p> <p>This bulletin applies to Ram trucks equipped with the 5.9L Cummins 24-valve diesel engine (sales code ETH) built on or after January 01, 2005. The vehicle operator may experience extended engine crank time in cold ambient temperatures on vehicles equipped with manual transmissions. This flash also provides the following enhancements:</p> <ul style="list-style-type: none"> • Improved start times for manual transmission vehicles • Improved automatic transmission shifting • Engine fan is activated if the coolant temperature sensor fails • Enhanced battery charging <p>This bulletin involves flash reprogramming the PCM (Cummins) with the software.</p>
18-005-06 Rev. B 05/31/06	'06 (DH/D1)	<p><i>Flash: DTC correction, turbocharger protection, and clutch durability improvement.</i></p> <p>This bulletin supersedes technical service bulletin 18-005-06 Rev. A, dated April 26, 2006. This bulletin applies to Ram trucks equipped with the 5.9L Cummins 24-valve diesel engine (sales code ETH) built on or after June 9, 2005, through and including May 31, 2006. The PCM software has been revised to address the following issues:</p> <ul style="list-style-type: none"> • A MIL may illuminate due to one or more of the following diagnostic trouble codes: P0071 – Inlet Air Temperature Sensor Rationality P0111 – Intake Air Temperature (IAT) Sensor Rationality P0514 – Battery Temperature Sensor Rationality P0191 – Fuel Pressure Rationality • Turbocharger durability improvement: Implemented an engine speed limitation when cold, to protect the turbocharger bearings. • Clutch durability improvement: Implemented a minimum engine speed limitation when launching vehicle from a stop, to protect the clutch. <p>This bulletin involves selectively erasing and reprogramming the PCM (Cummins) with new software.</p>

CATEGORY 18**VEHICLE PERFORMANCE**

<u>TSB #</u>	<u>MODELS</u>	<u>SUBJECT/DESCRIPTION</u>
18-022-07 03/14/07	'03-'05 (DR)	<p><i>Flash: 5.9L Turbo-Diesel engine system enhancements</i></p> <p>This bulletin applies to vehicles equipped with a 5.9L Turbo Diesel engine (sales codes ETC and ETH respectively). The bulletin supersedes 18-022-06 dated 07/13/06. The following enhancements are included with this software update:</p> <ul style="list-style-type: none">• Improved engine cooling (radiator fan activation) and prevention of possible engine overheating. When coolant temperature faults are present, the radiator fan is enabled (turned on) during vehicle operation.• Correction to oil pressure reading when engine is operating at higher engine temperatures above 195°F.• Improvement to the Temperature Sensor Rationality Test to prevent possible false test failures and their following related diagnostic trouble codes: DTC P0071 – Inlet Air Temperature Sensor Rationality DTC P0111 – Intake Air Temperature (IAT) Sensor Rationality DTC P0514 – Battery Temperature Sensor Rationality.• Additional water-in-fuel (WIF) warning added to indicate that the operator has had a WIF (DTC P2269) and has continued to operate the vehicle in excess of 500 miles without draining the water from the fuel filter. The following is the new WIF DTC that has been added: DTC P0169 – WIF Too Long Error• Improvement to the fuel pressure rationality test to prevent false test failures and the related DTC 0191. <p>This bulletin involves selectively erasing and reprogramming the engine control module with new software.</p>
18-038-06 12/05/06	'07 (DC)	<p><i>Flash: DTC P0471 – Exhaust pressure sensor rationality on Cummins 6.7-liter Turbo Diesel.</i></p> <p>This bulletin applies to vehicles equipped with a 6.7-liter engine (sales code ETJ) built on or before October 05, 2006. The vehicle operator may experience a malfunction indicator lamp (MIL) illumination due to diagnostic trouble code (DTC) P0471: exhaust pressure sensor rationality. This bulletin involves selectively erasing and reprogramming the engine control module (ECM-Cummins) with new software.</p>
18-001-07 01/06/07	'06-'07 (DH/D1)	<p><i>Flash: check gauges lamp illuminates for alternator charging with DTC P2502, P2503, or P2509</i></p> <p>This bulletin applies to vehicles equipped with a 5.9-liter engine (sales code ETH) built on or before November 29, 2006. The customer may experience the illumination of the "Check Gauges" lamp on the instrument panel cluster. Inspection of the gauges may reveal that the battery charging gauge may read in the 11-volt range rather than in the 14-volt range. There may not be a Check Engine/Malfunction Indicator Lamp (MIL) illumination.</p> <p>Further diagnosis may reveal the following diagnostic trouble codes (DTC's) have been set:</p> <ul style="list-style-type: none">P2502 – Charging System Error – DieselP2503 – Charging System Output Low – DieselP2509 – Powerdown Data Lost Error – Diesel <p>This bulletin involves selectively erasing and reprogramming the powertrain control module (Cummins PCM) with new software.</p>

CATEGORY 18**VEHICLE PERFORMANCE**

<u>TSB #</u>	<u>MODELS</u>	<u>SUBJECT/DESCRIPTION</u>
18-009-07 Rev. B 07/13/07	'07 (DC)	<p><i>Ram truck 3500 Cab and Chassis – Excessive soot accumulation in exhaust, PCM may not reprogram, and other engine system enhancements.</i></p> <p>This bulletin applies to Ram truck 3500 Cab and Chassis vehicles equipped with 6.7-liter Cummins Turbo Diesel engine (sales code ETJ). This bulletin supersedes technical service bulletin 18-009-07 Rev. A, dated May 16, 2007.</p> <p>The vehicle operator and/or technician may experience one or more of the following conditions:</p> <ul style="list-style-type: none">• The technician may not be able to reprogram (flash) the PCM with new application software.• After extensive idling of the vehicle engine or if an intake air leak is present, the vehicle operator may experience a MIL illumination and/or an electronic vehicle information center (EVIC) message alert due to one or more of the following DTC's:<ul style="list-style-type: none">P1451 – Diesel Particulate Filter System Performance.P2463 – Diesel Particulate filter – Soot AccumulationP242F – Diesel Particulate Filter Restriction – Ash Accumulation.• The vehicle operator may experience a MIL illumination due to one of the following DTC's:<ul style="list-style-type: none">P0101 – Manifold Absolute Pressure Sensor Performance.P0106 – Boost Pressure Sensor Rationality.P0191 – Fuel Rail Pressure Sensor Circuit Performance.• Improved Water-In-Fuel (WIF) alert. To improve awareness that water has been detected in the fuel system, the vehicle operator will be alerted to a five (5) chime alert versus a single (1) chime alert. <p>This bulletin involves selectively erasing and reprogramming the powertrain control module (PCM) with “bootloader” software and application software.</p>
18-030-07 04/26/07	'04-'07 (DR/DH/D1/DC)	<p><i>Engine off-idle speed limit feature to protect turbocharger when vehicle is not moving.</i></p> <p>This bulletin applies to vehicles equipped with a 5.9-liter or a 6.7-liter Cummins Turbo Diesel engine (sales codes: ETC, ETH, or ETJ). This bulletin involves a discussion regarding an engine control feature that limits engine off-idle speeds when the vehicle is not moving.</p> <p>Dependent upon engine coolant temperature, the engine control module (ECM) will temporarily limit the maximum engine speed when the vehicle is not moving. For automatic transmission equipped vehicles the maximum engine speed is temporarily delayed when the vehicle speed is less than one mph, and when the transmission selector is in either the neutral or park position. For manual transmission equipped vehicles, the maximum engine speed is temporarily delayed when the vehicle speed is less than one mph. This ECM feature is used to protect the engine turbocharger.</p> <p>This delay in maximum engine and turbocharger shaft speed allows for sufficient oil lubrication to the turbocharger shaft bearings which is important for long term turbocharger durability.</p> <p>The maximum engine speed for the 5.9-liter engine is temporarily limited to 1,600 RPM when the above conditions are met. The 6.7-liter engine speed is temporarily limited to 1,200 RPM when the above conditions are met. The length of time that the maximum engine speed is temporarily limited is dependent upon engine coolant temperature. For example, the delay can be up to 45 seconds at 35° or 7 seconds at 70°.</p>

CATEGORY 18**VEHICLE PERFORMANCE**

TSB #	MODELS	SUBJECT/DESCRIPTION
18-033-07 Rev. B 06/28/07	'07 (DH/D1)	<p><i>Ram truck 2500 and 3500 – Excessive soot accumulation in exhaust, PCM may not reprogram, OBD readiness status and other engine system enhancements.</i></p> <p>This bulletin applies to Ram truck 2500 and 3500 vehicles equipped with 6.7-liter Cummins Turbo Diesel engine (sales code ETJ) built on or before June 11, 2007. This bulletin supersedes technical service bulletin 18-033-07 Rev. A, dated June 12, 2007.</p> <p>The vehicle operator and/or technician may experience one or more of the following conditions and/or enhancements:</p> <ul style="list-style-type: none">• The technician may not be able to reprogram (flash) the PCM with new application software.• The vehicle may fail an emission inspection maintenance (I/M) test because two or more on-board diagnostic (OBD) monitors report that they are not ready for testing. This condition may cause the customer vehicle to fail an emissions I/M test. The following is a list of OBD Monitors that may report as not ready for testing:<ul style="list-style-type: none">a. Non-Methane Hydrocarbon (NMHC) Catalyst Monitor.b. Nitrogen Oxide (NOx) Absorber Monitor.c. Exhaust Gas Temperature Sensor Monitor.d. Electrical Charging System Monitor.e. EGR System Monitor.f. Oxygen Sensor Monitor.• After extensive idling of the vehicle engine or if an intake air leak is present, the vehicle operator may experience a MIL illumination and/or an electronic vehicle information center (EVIC) message alert due to one or more of the following DTCs:<ul style="list-style-type: none">P1451 – Diesel Particulate Filter System performanceP2463 – Diesel Particulate Filter – Soot AccumulationP242F – Diesel Particulate Filter Restriction – Ash Accumulation.• The vehicle operator may experience a MIL illumination due to one of the following DTC's:<ul style="list-style-type: none">P0106 – Manifold Absolute Pressure Sensor Performance.P242B – Exhaust Gas Temperature Sensor Circuit Performance – Bank 1 Sensor 3P245A – EGR Cooler Bypass Control Circuit – Open• An intermittent rough engine idle and/or white smoke following initial engine start.• A throttle tip-in stumble at engine speeds of 1,300 to 2,100 rpm.• An engine hesitation at altitude of 5,000 feet between engine speeds of 1,200 to 1,600 rpm.• A turbocharger “chuff-like” sound during rapid deceleration. <p>This bulletin involves selectively erasing and reprogramming the Powertrain Control Module (PCM) with “bootloader” software and application software.</p> <p>In October of '07 this TSB (and the number of fault codes addressed by the reprogramming of the ECM) was superseded by a recall (Recall G30) of all 6.7-liter engines built to that date. The TSB 18-033-07 was left in the magazine to give 6.7-liter owners data to see what the Recall G30 scope of work entailed.</p> <p>Then in December of '08 the G30 recall and the TSB 18-013-08 that described the proper repair technique were updated again by TSB 18-013-08A.</p>
18-037-07 Rev. A 07-20-07	'07 (DH/D1)	<p><i>68RFE Transmission – DTC P0868 low line pressure.</i></p> <p>This bulletin applies to vehicles equipped with a 68RFE automatic transmission (sale code DG7) built on or before April 30, 2007. The customer may experience a malfunction indicator lamp (MIL) illumination due to diagnostic trouble code (DTC) P0868-Low Line Pressure. This condition may be due to the transmission control module (TCM) software or to a hardware circuit in the TCM.</p> <p>This bulletin involves checking the transmission control module (TCM) to determine that it is in proper working order and then selectively erasing and reprogramming the TCM with new software</p>

CATEGORY 18**VEHICLE PERFORMANCE**

<u>TSB #</u>	<u>MODELS</u>	<u>SUBJECT/DESCRIPTION</u>
18-013-08 3/13/08	'07-'08	<p><i>Engine system and exhaust aftertreatment system enhancements.</i></p> <p>This bulletin applies to vehicles equipped with a Cummins 6.7-liter engine (sales code ETJ) built on or before February 14, 2008. This bulletin discusses the G30 recall and the many drivability issues that are addressed and covered in the G30 recall software update.</p>
18-013-08 REV. A 12/4/08	'07-'09 (DH/D1)	<p><i>Engine system and exhaust aftertreatment system enhancements.</i></p> <p>This bulletin applies to vehicles equipped with a Cummins 6.7-liter engine (sale code ETJ) built on or before November 27, 2008. This bulletin supersedes technical service bulletin 18-013-08, dated March 13, 2008. This bulletin involves verifying that Emission Recall G30 - Replace Oxygen Sensor Module and Reprogram ECM has been performed. If not, perform Recall G30 first, then verify the software level, and if necessary, selectively erasing and reprogramming the Engine Control Module (ECM) with new software. Additionally, verify the software level, and if necessary, selectively erasing and reprogramming the Cab Compartment Node (CCN) module with new software. With this latest ECM software release listed in this Service Bulletin, the following symptoms have been completely addressed.</p> <ul style="list-style-type: none">• One of the following driveability conditions:<ul style="list-style-type: none">a. An intermittent rough engine idle and/or white smoke following initial engine start.b. A throttle tip-in stumble at engine speeds of 1,300 to 2,100 rpm.c. An engine hesitation at altitude of 5,000 feet between engine speeds of 1,200 to 1,600 rpm.d. A turbocharger "chuff-like" sound during rapid deceleration.• The vehicle may fail an Emission Inspection Maintenance (I/M) Test because two or more On-Board Diagnostic (OBD) monitors report that they are not ready for testing. This condition may cause the customer vehicle to not pass an Emissions I/M test. The following is a list of OBD Monitors that may report as not ready for testing:<ul style="list-style-type: none">a. Non-Methane Hydrocarbon (NMHC) Catalyst Monitor.b. Nitrogen Oxide (NOx) Absorber Monitor.c. Exhaust Gas Temperature Sensor Monitor.d. Electrical Charging System Monitor.e. EGR System Monitor.f. Oxygen Sensor Monitor.• Malfunction Indicator Lamp (MIL) due to one or more of the following Diagnostic Trouble Codes (DTC's):<ul style="list-style-type: none">a. P0101 - Mass Air Flow (MAF) Sensor Rationalityb. P0128 - Thermostat Rationalityc. U1421 - Implausible Ignition Key Off Time Received. <p>The latest ECM software includes a new extended idle feature to accommodate the extended idle times present in some duty cycles. This feature may help to reduce the accumulation of soot in the exhaust aftertreatment system when the engine is idling for an extended period of time.</p> <p>A number of improvements have been made to the engine diagnostics. Performing this Service Bulletin completely will enable these diagnostic improvements.</p>

CATEGORY 18**VEHICLE PERFORMANCE**

18-013-08
REV. A
12/4/08
continued

To determine if the vehicle has the latest software, compare the software level to the following notes:

- If the vehicle in question is a 2007 model year vehicle, then compare the current ECM software level part number to one of the following part numbers (or with a higher suffix):
 - 55350430AZ (or higher) = DH 2500 6.7L Manual Transmission 50 State
 - 55350435AZ (or higher) = DH 2500 6.7L Automatic Transmission 50 State
 - 55351430AZ (or higher) = D1 3500 6.7L Manual Transmission 50 State
 - 55351435AZ (or higher) = D1 3500 6.7L Automatic Transmission 50 State
- If the vehicle in question is a 2008 model year vehicle, then compare the current ECM software level part number to one of the following part numbers (or with a higher suffix):
 - 62350430AR (or higher) = DH 2500 6.7L Manual Transmission 50 State
 - 62350435AR (or higher) = DH 2500 6.7L Automatic Transmission 50 State
 - 62351430AR (or higher) = D1 3500 6.7L Manual Transmission 50 State
 - 62351435AR (or higher) = D1 3500 6.7L Automatic Transmission 50 State
- If the vehicle in question is a 2009 model year vehicle, then compare the current ECM software level part number to one of the following part numbers (or with a higher suffix):
 - 72350430AF (or higher) = DH 2500 6.7L Manual Transmission 50 State
 - 72350435AF (or higher) = DH 2500 6.7L Automatic Transmission 50 State
 - 72351430AF (or higher) = D1 3500 6.7L Manual Transmission 50 State
 - 72351435AF (or higher) = D1 3500 6.7L Automatic Transmission 50 State
- Determine if the current CCN module level software part number is one of the following (or with a higher suffix):
 - 05172187AG (or higher) = 2007 DH (2500) or 2007 D1 (3500)
 - 05172334AG (or higher) = 2008 DH (2500) or 2008 D1 (3500)
 - 05172529AG (or higher) = 2009 DH (2500) or 2009 D1 (3500)

18-035-08 '07-'08 (DH/D1)
9/13/08

MIL illumination due to P2000, P2A00 and/or P2A01.

The customer may experience MIL illumination. Further investigation by the technician may find one or more of the following DTC(s) present:

- P2000 - NOx Absorber Efficiency Below Threshold - Bank 1.
- P2A00 - O2 Sensor 1/1 Circuit Performance.
- P2A01 - O2 Sensor 1/2 Circuit Performance.

This bulletin involves verifying all TSBs related to high sooting issues have been properly addressed, replacing both Oxygen (O2) Sensors, and wrapping the exhaust pipe in the area of the FRONT O2 sensor.

CATEGORY 18**VEHICLE PERFORMANCE**

TSB #	MODELS	SUBJECT/DESCRIPTION
18-001-09 1/21/09	'07-'09 (DC/DM) (3500/4500/5500 Cab/Chassis)	<p><i>Engine systems and exhaust aftertreatment systems enhancements.</i></p> <p>This bulletin applies to vehicles equipped with a Cummins 6.7-liter engine (sales code ETJ) built on or before January 13, 2009. This bulletin supersedes technical service bulletin 18-009-07 Rev. B, dated July 13, 2007.</p> <p>This bulletin involves verifying that the latest software has been installed on 2007 MY vehicles. Selectively erasing and reprogramming the Engine Control Module (ECM). Selectively erasing and reprogramming the Cab Compartment Node (CCN).</p> <p>The latest PCM software will address the erroneous MIL illumination of the following faults:</p> <ul style="list-style-type: none"> P0191 - Fuel Rail Pressure Sensor Circuit Performance P0128 - Thermostat Rationality P0106 - Manifold Absolute Pressure Sensor Performance P0524 - Engine Oil Pressure Too Low P061A - ETC Level 2 Torque performance P0607 - ECU Internal Performance <p>The latest PCM software will include the following operational and diagnostic improvements: Improve engine cooling capability and prevention of over temp condition (P0217 - Coolant Temperature Too High) when operating with snow plow. New feature that allows for customer selectable remote PTO speed (if equipped). The latest ECM software includes a new extended idle feature to accommodate the extended idle times present in some duty cycles. This feature may help to reduce the accumulation of soot in the exhaust aftertreatment system when the engine is idling for an extended period of time.</p> <p>To determine if the vehicle has the latest software, compare the following notes:</p> <ul style="list-style-type: none"> • If the vehicle in question is a 2007 model year vehicle, then compare the current PCM software level part number to one of the following part numbers (or with a higher suffix): <ul style="list-style-type: none"> 52300430AX (or higher) = DC 3500 6.7L Manual Transmission 50 State 55300434AX (or higher) = DC 3500 6.7L Automatic Transmission 50 State • If the vehicle in question is a 2008 model year vehicle, then compare the current PCM software level part number to one of the following part numbers (or with a higher suffix): <ul style="list-style-type: none"> 61300430AK (or higher) = DC 3500 6.7L Manual Transmission 50 State 61300434AK (or higher) = DC 3500 6.7L Automatic Transmission 50 State 61301430AK (or higher) = DM 4500/5500 6.7L Manual Transmission 50 State 61301434AK (or higher) = DM 4500/5500 6.7L Automatic Transmission 50 State • If the vehicle in question is a 2009 model year vehicle, then compare the current PCM software level part number to one of the following part numbers (or with a higher suffix): <ul style="list-style-type: none"> 71300430AH (or higher) = DC 3500 6.7L Manual Transmission 50 State 71300434AH (or higher) = DC 3500 6.7L Automatic Transmission 50 State 71301430AH (or higher) = DM 4500/5500 6.7L Manual Transmission 50 State 71301434AH (or higher) = DM 4500/5500 6.7L Automatic Transmission 50 State • Determine if the current CCN module level software part number is one of the following (or with a higher suffix): <ul style="list-style-type: none"> 05172187AH (or higher) = 2007 DC (3500) / DM (3500/4500) 05172334AG (or higher) = 2008 DC (3500) / DM (3500/4500) 05172529AG (or higher) = 2009 DC (3500) / DM (3500/4500)
18-024-09 8/6/09	'07-'09 (D1/DH)	<p><i>MIL illumination and stationary DeSoot and other enhancements.</i></p> <p>This bulletin applies to D1/DH vehicles equipped with a 6.7-liter Cummins engine (sales code ETJ) built before May 5, 2009. The customer may experience:</p> <ul style="list-style-type: none"> • An erroneous MIL illumination for P2262 - Turbocharger Boost Pressure Not Detected - Mechanical. • Improved diagnostics for P2299 - Brake Pedal Position/Accelerator Pedal position Incompatible. • An erroneous MIL illumination for P0402 - Exhaust Gas Recirculation (EGR) Flow Excessive Detected. • An erroneous MIL illumination for P040B - EFR Temperature Sensor 1 Circuit Performance. • An erroneous MIL illumination for P0405 - EFR Position Sensor Circuit Low. <p>This bulletin involves selectively erasing and reprogramming the Engine Control Module (ECM) with new software.</p>

CATEGORY 19 STEERING

<u>TSB #</u>	<u>MODELS</u>	<u>SUBJECT/DESCRIPTION</u>
19-003-02 4/15/02	'97-'02 (BR/BE)	<p><i>Hissing sound coming from the power steering system on vehicles equipped with hydroboost brakes.</i></p> <p>A hissing sound may be present in the power steering system during steering maneuvers or straight ahead driving. This bulletin involves replacing the power steering hoses connecting the hydroboost to the power steering pump and gear.</p>
19-005-03 8/29/03	'94-'02 (BR/BE) '02-'04 (DR)	<p><i>Power steering fluid usage.</i></p> <p>The factory fill power steering fluid for most 2004 model year Chrysler Group vehicles is ATF+4 (part number 05013457AA/S9602) and it provides superior performance at both low and high temperatures. Refer to the table to identify factory fill and the approved service power steering fluid by year and model. From the table it is noted that the '94 to '02 truck uses part number 04883077/MS5931. MS9602 should not be mixed or used as a "topping off" fluid on systems requiring MS5931.</p>
19-008-03 11/28/03	'03 (DR)	<p><i>Vibration in steering column.</i></p> <p>A vibration may be felt in the steering wheel and/or the accelerator pedal on diesel engine vehicles with the engine operating between 2000 and 2200 rpm. The vibration may be more pronounced with the A/C compressor on. Operate the engine between 2000 and 2200 rpm. If the vibration is present, perform the repair procedure which involves installing a power steering hose containing a vibration damper.</p>
19-010-04 11/29/04	'04-'05 (DR)	<p><i>Power steering fluid contamination.</i></p> <p>This information-only bulletin discusses the use of supplements to the power steering fluid. Do not use fluids or supplements that contain Teflon as they will cause a restriction at the filter in the power steering system. The power steering fluid used in Chrysler Group vehicles is an engineered product. The addition of any unapproved fluids or supplements can interfere with the proper function of the fluid and cause damage to the steering system. To ensure the performance and durability of Chrysler Group steering systems, use only Mopar Power Steering Fluid +4, ATF+4 automatic transmission fluid, or equivalent (MS-9602), in the power steering system.</p>
19-003-05 5/3/05	'03-'05 (DR)	<p><i>In and out movement in steering column.</i></p> <p>This bulletin applies to vehicles built after December 1, 2003. If there is a small amount of movement in the steering column when pulling the steering wheel toward you while seated in the driver's seat, the TSB outlines the proper repair procedure which involves the installation of a steering retainer kit to the steering column.</p>
19-008-05 Rev. A 11/2/05	'02-'06 (DR)	<p><i>Revised power steering system bleeding procedures.</i></p> <p>This bulletin supersedes service bulletin 19-008-05, dated October 26, 2005. The bulletin discussed that Mopar Power Steering fluid +4 or ATF+4 (MS-9602) is to be used in the power steering system of DR vehicles. No other power steering or automatic transmission fluid is to be used in these systems. Damage may result to the power steering pump and system if the incorrect fluid is used. Do not overfill the power steering reservoir. If the air is not purged from the power steering system correctly, pump failure could result.</p>

CATEGORY 21**TRANSMISSION**

<u>TSB #</u>	<u>MODELS</u>	<u>SUBJECT/DESCRIPTION</u>
21-023-05 11/11/05	'06	<p><i>Out of park sense alarm.</i></p> <p>This information only bulletin applies to vehicles equipped with a 5.9L Turbo Diesel engine (sales code ETH). This information only bulletin discusses an alarm for "out of park" transmission setting. Vehicles with a diesel engine and an automatic transmission are equipped with an alarm that warns the customer, upon exiting the vehicle, that the transmission is not in the "Park" position. This feature will only be functional under the following conditions:</p> <ul style="list-style-type: none">• engine running• foot off the brake pedal• driver's seat belt unbuckled• driver's door open. <p>When this feature is triggered the horn will sound and the high beams and turn signal lamps will flash. This feature is standard equipment and cannot be disabled.</p>
21-006-06 3/11/06	'05-'06	<p><i>Transmission jumps out of reverse.</i></p> <p>This bulletin applies to vehicles equipped with Cummins Turbo Diesel engines, sales code ETH and G56 manual transmissions sales code DEG. A customer may experience the transmission jumping out of reverse. If the customer indicates that the condition is present, perform the repair procedure which involves replacing the reverse synchronizer.</p>
21-010-06 4/14/06	All	<p><i>Automatic transmission fluid usage ATF+4 (Type MS9602).</i></p> <p>This bulletin supersedes technical service bulletin 21-004-04, dated March 16, 2004. ATF+4, type 9602, is being used as factory fill for Chrysler Group automatic transmissions. ATF+4 is recommended for all vehicles equipped with Chrysler Group automatic transmissions except for those noted: AW-4 transmissions, Sprinter transmissions, Crossfire transmissions, MK/PM vehicles equipped with Continuously Variable Transmission (CVT). ATF+4 is backward compatible with ATF+3, ATF+2, and ATF+. Additionally, ATF+4 can be used to top off vehicles that used ATF+3, ATF+2, or ATF+. Benefits:</p> <ul style="list-style-type: none">• Better anti-wear properties• Improved rust/corrosion prevention• Controls oxidation• Eliminates deposits• Controls friction• Retains anti-foaming properties• Superior properties for low temperature operation. <p>Mopar ATF+4 has exceptional durability. However, the red dye used in ATF+4 is not permanent; as the fluid ages it may become darker or appear brown in color. ATF+4 also has a unique odor that may change with age. With ATF+4 fluid, color and odor are no longer indicators of fluid condition and do not necessarily support a fluid change.</p>
21-003-07 02/09/07		<p><i>Automatic transmission diagnostic tear down procedure.</i></p> <p>This bulletin provides a procedure to determine repair versus replacement of an automatic transmission assembly. Follow the proper repair procedure based on the transmission type. This procedure is to be used after the transmission has been removed from the vehicle.</p> <p>This bulletin supersedes technical service bulletin 21-008-06, dated 04/08/06. This bulletin supersedes technical service bulletin 21-021-08, dated 09/17/08.</p>
21-006-07 03/20/07	'05 (DH)	<p><i>Flash: New 48RE feature that allows normal shift schedule with full disable of 4th gear overdrive.</i></p> <p>This bulletin applies to vehicles equipped with a 5.9-liter Cummins Turbo Diesel engine and a 48RE automatic transmission (sales codes ETH and DG8 respectively). A new 48RE transmission feature is added that will allow normal shift schedule with full disable of 4th gear (overdrive gear), when the customer selects the Over-Drive (O/D) switch.</p> <p>Prior to the implementation of this new transmission feature, the use of the O/D switch changed the automatic transmission shift schedule from a "normal" shift schedule to a tow/haul mode shift schedule, and allowed 4th gear (overdrive gear) engagement.</p> <p>This new transmission feature will not change the transmission shift schedule, but will allow full 4th gear overdrive disable (lock out). With this new feature the customer will have the "normal" shift schedule with NO overdrive (4th gear).</p> <p>This bulletin involves selectively erasing and reprogramming the Cummins Engine Control Module (ECM) with new software.</p>

CATEGORY 21**TRANSMISSION**

<u>TSB #</u>	<u>MODELS</u>	<u>SUBJECT/DESCRIPTION</u>
21-009-07 5/24/07	'04-'07	<p><i>48RE Transmission – 1-2 shift hunt at light throttle.</i></p> <p>The customer may experience a 1-2 shift transmission hunt during light throttle application. This condition may be due to a governor pressure solenoid valve. This bulletin involves the replacement of the governor pressure solenoid valve in the transmission valve body.</p>
21-014-07	All	<p><i>Automatic transmission fluid usage ATF+4 (Type MS9602).</i></p> <p>This bulletin supersedes technical service bulletin 21-010-06, dated 4/16/06. ATF+4, type 9602, is being used as factory fill for Chrysler Group automatic transmissions. ATF+4 is recommended for all vehicles equipped with Chrysler Group automatic transmissions except for those noted: Sprinter transmissions, Crossfire transmissions, MK/PM vehicles equipped with Continuously Variable Transmission (CVT), all vehicles equipped with a A568RC transmission (sales code DG3), all vehicles with a Getrag MP56 (sales code DG5), and Grand Cherokees with the diesel engine option. ATF+4 is backward compatible with ATF+3, ATF+2, and ATF+. Additionally, ATF+4 can be used to top off vehicles that used ATF+3, ATF+2, or ATF+. Benefits:</p> <ul style="list-style-type: none"> • Better anti-wear properties • Improved rust/corrosion prevention • Controls oxidation • Eliminates deposits • Controls friction • Retains anti-foaming properties • Superior properties for low temperature operation. <p>Mopar ATF+4 has exceptional durability. However, the red dye used in ATF+4 is not permanent; as the fluid ages, it may become darker or appear brown in color. ATF+4 also has a unique odor that may change with age. With ATF+4 fluid, color and odor are no longer indicators of fluid condition and do not necessarily support a fluid change.</p>
21-019-07 11/14/07	'07-'08 (DH/D1) 2500/3500	<p><i>68RFE transmission – harsh coast downshift and/or harsh 2-3 upshift.</i></p> <p>This bulletin applies to vehicles equipped with a 68RFE automatic transmission (sale code DG7) built on or before November 6, 2007. The customer may experience a harsh downshift from the transmission when coming to a stop. When a vehicle stop is initiated from 4th gear (around 25mph), the harsh downshift condition will usually occur as the vehicle decelerates to a speed of about 10mph. If the transmission is in 2nd, 3rd, 5th, or 6th gear when the stop is initiated, the condition will not be present. This may cause the condition to appear to be intermittent to the customer. Because the harsh downshift may occur below 10mph, the customer may believe that they are experiencing a harsh 2-1 downshift.</p> <p>Some customers may also experience a harsh 2-3 upshift during normal acceleration. This symptom is less common than the harsh coast downshift.</p> <p>This bulletin involves selectively erasing and reprogramming the transmission control module (TCM) with new software.</p>
21-021-08 9/17/08	'95-'02 (BR/BE) '07-'09 (D1/DC) '02-'09 (DR/DH)	<p><i>Automatic transmission diagnostic tear down procedure.</i></p> <p>This bulletin provides a procedure to determine repair versus replacement of an automatic transmission assembly. Follow the proper repair procedure based on the transmission type. This procedure is to be used after the transmission has been removed from the vehicle.</p>

CATEGORY 22**WHEELS & TIRES**

<u>TSB #</u>	<u>MODELS</u>	<u>SUBJECT/DESCRIPTION</u>
22-001-05 12/1/05	'00-'01 (BR/BE) '02-'06 (DR)	<i>Chrome wheel care.</i> This information-only bulletin discusses chrome wheel care. Chrome wheels should be cleaned regularly with mild soap and water or Mopar Car Wash Concentrate to maintain their luster and prevent corrosion. Wash them with the same soap solution as the body of the vehicle. Care must be taken in the selection of tire and wheel cleaning chemicals and equipment to prevent damage to wheels. Any of the "Do Not Use" items listed below can damage or stain wheels and wheel trim. <ul style="list-style-type: none"> • Wheel cleaners that contain hydrofluoric acid, bifluoride compounds, sulfuric acid, or phosphoric acid. • Any abrasive type cleaner. • Any abrasive cleaning pad (such as steel wool) or abrasive brush. • Any oven cleaner. • A car wash that has carbide tipped wheel-cleaning brushes.
22-005-06 10/07/06	'03-'07 (DR/DH/D1/DC)	<i>Front end shimmy on 4x4 vehicles when traveling over rough surfaces in the road.</i> This bulletin applies to four wheel drive (4x4) 2500 and 3500 model vehicles. The customer may experience a self sustaining vibration (shimmy) felt in the front end of the vehicle after striking a bump or pothole. This bulletin involves verifying the condition of the vehicle front suspension and steering components, and adjusting the front tire pressure. If the customer experiences the above condition, perform the repair procedure which includes a steering damper, tie rods and end links.
22-002-07 Rev. A 7/12/07	'08 (DH) 2500	<i>Tire pressure monitor system (TPMS) "Light Load" reset switch and tire rotation caution.</i> This information-only bulletin provides information for new vehicle preparation, setting tire pressures, rotating tires and setting the light load switch on vehicles with the tire pressure monitoring system installed.

CATEGORY 23**BODY**

<u>TSB #</u>	<u>MODELS</u>	<u>SUBJECT/DESCRIPTION</u>
23-018-02 5/20/02	'00-'01 (BR/BE)	<i>Armrest lid difficult to open.</i> The armrest lid may be difficult to latch or if latched, may be difficult to open. This may be caused by an improperly adjusted latch pin. This bulletin involves adjusting the armrest lid latch pin.
23-018-03 6/13/03	'03 (DR)	<i>Instrument panel whistle.</i> A whistling sound may be present coming from the front of the instrument panel near the bottom of the windshield when the heater A/C blower is on. This may be caused by air escaping through the holes in the center of the rivets that attach the VIN plate to the instrument panel. This can be mis-diagnosed as a windshield air leak. If necessary, remove the instrument panel top cover and apply a small drop of clear glass sealer to the center of each of the rivets to seal the rivet holes.
23-016-03 6/13/03	'03 (DR)	<i>Buzzing or vibrating sound coming from the front of the vehicle.</i> The description of the problem is a buzzing or vibrating sound coming from the front of the vehicle at highway speeds. Open the hood and inspect the ID plate located on the radiator support. The ID plate should be attached with four rivets. If there are only two rivets securing the ID plate, the ID plate may be vibrating against the radiator support. The repair involves securing the ID plate with additional rivets.
23-025-03 10/24/03	'03 (DR)	<i>Scratched aftermarket window tint film.</i> Customers who have installed aftermarket window tint film see scratches on the film on the windows from contact with the door inner belt weather strip. Some vehicles may have been built with the weather strip not having a coating of soft protective flocking on the surface that contacts the window. The repair involves installing a revised door inner belt weather strip.

CATEGORY 23**BODY**

TSB #	MODELS	SUBJECT/DESCRIPTION
23-001-04 1/13/04	'03 (DR)	<i>Bug deflector wind whistle.</i> Some vehicles equipped with a factory installed hood mounted bug deflector may exhibit a whistling sound coming from the front of the vehicle. The repair procedure involves installing foam tape to the bug deflector.
23-003-04 1/27/04	'02-'04 (DR)	<i>Water leak at grab handle.</i> Water may enter the vehicle through the secondary door seal retainer or the roof seam, onto the headliner and run down the "A" pillar, coming out at the grab handle. The repair involves sealing holes in the roof panel.
23-011-04	'04 (DR)	<i>Cup holder binds or sticks.</i> If the cup holder binds, will not open, or only opens partially, the instrument panel trim should be adjusted to provide clearance for the cup holder.
23-011-04	'03-'04 (DR)	<i>Bug deflector loose/rattling.</i> This bulletin applies to vehicles equipped with a factory installed bug deflector, sales code MXB. The bug deflector or air dam located on the front of the hood may become loose and rattle. The deflector could become dislodged in an automatic car wash. The repair involves replacing the bug deflector fasteners.
23-029-04 8/2/04	'04 (DR)	<i>Binding front power window.</i> This bulletin applies to vehicles equipped with trailer tow mirrors, sales code GPD or GPG. Vehicle owners may experience the power window on the front door binding or slow to operate. The corrective action involves lubricating the window channel and installing a spacer under the outside mirror.
23-005-05 1/31/05	'03-'04 (DR)	<i>Improved secondary door seal.</i> Mud or dirt may accumulate on the rocker panel, causing customers to complain that their clothing gets dirty when they enter or exit the vehicle. This bulletin involves installing a new lower secondary door seal
23-022-05 4/2/05	'05 '06 (DR)	<i>Low gloss interior trim.</i> This information-only bulletin discusses that all Chrysler, Dodge, and Jeep vehicles are designed with a low gloss interior trim. This low gloss finish maintains pleasing aesthetics, and minimizes glare of the instrument panel into the windshield. This low gloss finish should not be altered with a medium or high gloss interior treatment solution such as MOPAR Protector's or other Armor All-like products. Instead, MOPAR Satin Select (part number 05174395AA) which has been specifically developed to remove minor surface contamination and maintain the low gloss appearance, should be used for interior trim treatment.
23-049-05 10/12/05	'04-'05 (DR)	<i>Drip rail door seal torn.</i> The drip rail or secondary door seal may become torn from contact with the lower "A" pillar of the front door. The repair involves replacing the secondary door seal with an improved seal.
23-009-06 2/14/06	'04-'05	<i>Water leak at roof mounted marker lamps.</i> Water leaks may be present coming from the roof mounted marker lamps. New marker lamps have been released which contain base gaskets. These marker lamps should be used in all cases where water leaks are present at the marker lamps. These lamps will have to be replaced in sets of five due to appearance differences. If water leak tests reveal that water leaks are present at the marker lamps, perform the repair procedure.

CATEGORY 23**BODY**

TSB #	MODELS	SUBJECT/DESCRIPTION
23-014-06 3/8/06	All	<p><i>Windshield wiper blade maintenance.</i></p> <p>Windshield wiper blades/elements are frequently replaced unnecessarily. If the wipe pattern appears to be streaky or if there is chatter and no damage to the wiper blades/elements is obvious, the following steps should be performed:</p> <ul style="list-style-type: none">• Use a soft cloth or sponge and squeegee and a solution of 50/50 alcohol and water, to wash the windshield.• Raise the wiper blades off the glass and clean the wiper blade elements with a solution of 50/50 alcohol and water and a soft cloth, paper towel or sponge.• Return the wiper blades to their normal operating position. If the wipe pattern is still objectionable, repeat several times. If the wipe pattern is still objectionable, replace the wiper blades/elements.
23-018-06 5/5/06	'06 (DR)	<p><i>Speaker buzz.</i></p> <p>Customers may experience a buzzing sound coming from the door area when the radio is on. This bulletin involves adding insulating tape to the inner door and door trim panel.</p>
23-004-07 01/26/07	'04-'07 (DR)	<p><i>Transit film removal.</i></p> <p>This information only bulletin provides a transit film removal procedure.</p>
23-021-06 Rev. A 08/09/06	'07 (DR)	<p><i>YES Essentials stain, odor, and static resistant fabric care.</i></p> <p>This bulletin applies to vehicles equipped with YES Essentials stain, odor, and static resistant fabric (sales code XGW). YES Essentials fabric is an easy-care material that repels and releases soil to maintain the like-new appearance. Spills remain on the surface of the fabric to allow for easy clean up and to prevent stains and odors. The material is antimicrobial and static resistant.</p> <p>YES Essentials fabric may be cleaned in the following manner:</p> <ul style="list-style-type: none">• Remove as much of the stain as possible by blotting with a clean, dry towel.• Blot any remaining stain with a clean, damp towel.• For tough stains, apply Mopar Total clean, p/m 04897840AA, or a mild soap solution to a clean damp cloth and remove the stain. Use a fresh, damp towel to remove the soap residue.• For grease stains, apply Mopar Multi-purpose Cleaner, p/n 05127532AA, to a clean, damp cloth and remove the stain. Use a fresh, damp towel to remove the soap residue.• Do NOT use any solvents or fabric protectants on Yes Essentials fabric.
23-047-06 10/21/06	'06-'07 (DR/DH/D1)	<p><i>Cracked windshield.</i></p> <p>Windshield cracks caused by an impact from a foreign object (i.e. stone) are often difficult to identify. The following assessment should be used to verify the presence of an impact chip on the crack.</p> <p>If no obvious impact chip is present, run a ball point pen along the crack and feel for a slight drop or pit in the glass. If a slight drop or pit in the glass is present, this indicates a small impact caused the crack. If the molding contains a witness mark or dent from an impact, inspect under the molding for an impact chip in the same manner. Cracks caused by an impact are not warrantable.</p>
23-010-07 3/24/07	'06-'07 (DR/DH/D1) 1500/2500/3500	<p><i>Water leak due to small void in backlite sealer.</i></p> <p>The customer may experience the presence of water on or under the rear area floor carpet. This condition is likely due to water leaking past a small void in the adhesive used to retain the backlite glass to the body panel. It is recommended that a flowable sealer be applied to seal a small void in the backlite adhesive.</p>
23-011-07 3/30/07	'06-'07 (DR/DH/D1) 1500/2500/3500	<p><i>Glass keeper loose on back power sliding window.</i></p> <p>The customer may notice that the glass keeper on the rear backlite has separated from the glass. The bulletin gives directions for the proper repair procedure.</p>

CATEGORY 23**BODY**

<u>TSB #</u>	<u>MODELS</u>	<u>SUBJECT/DESCRIPTION</u>
23-013-07 04/13/07	'02-'07 (DR/DH/D1/DC)	<p><i>Trailer Towing Mirror – New mirror glass locking tab, new removal procedure.</i></p> <p>This bulletin applies to vehicles equipped with trailer tow mirrors (sales codes GPD or GPG) built after April 16, 2007, and for any vehicle where service replacement of the mirror glass is required.</p> <p>The trailer towing mirror assembly has a replaceable mirror glass. As part of the replaceable mirror glass, a locking tab has been added to the plastic backing on the mirror glass. This change has been made to vehicles built after April 16, 2007. This change is also being incorporated in service replacement of mirror glass.</p> <p>This bulletin involves a discussion regarding new removal procedure when replacing the mirror glass on a trailer tow mirror.</p>
23-028-07 Rev.A 7/20/07	'06-'07 (DR/DH/D1) 1500/2500/3500	<p><i>Buzz-like sound from front door speaker area when radio is on.</i></p> <p>The sound in question will come from the interior door trim panel, in the area where the radio speaker is mounted. This condition may be misdiagnosed as a bad radio speaker. The actual cause is typically the interface between the door trim panel sound insulation and the door water shield. The repair procedure involves the addition of sound insulation to the door panel.</p>
23-035-07 08/08/07	'06-'08 (DC/DM/DR/ DH/D1)	<p><i>Exterior Lamp – lens fogging.</i></p> <p>Some customers may report that vehicle exterior lamp assemblies are fogged with a light layer of condensation on the inside of the lenses. This may be reported after the lamps have been turned on and brought up to operating temperature, turned off, and then rapidly cooled by cold water (such as rain, or the water from a car wash). Lens fogging can also occur under certain atmospheric conditions after a vehicle has been parked outside overnight (i.e., a warm humid day followed by clear cool night). This will usually clear as atmospheric conditions change to allow the condensation to change back into a vapor. Turning the lamps on will usually accelerate this process.</p> <p>A lamp that has a large number of water droplets visible on most internal surfaces indicates a problem with the lamp sealing that has allowed water to enter the lamp. In this instance, the customer is likely to report that moisture in the lamp is always present and never disappears. A lamp that exhibits internal moisture permanently should be replaced.</p> <p>This bulletin supersedes technical service bulletin 23-041-06, dated September 27, 2006.</p>
23-017-08 5/10/08	'08 (DR/DH/D1) 1500/2500/3500	<p><i>Tailgate retaining cables appear to be of unequal lengths.</i></p> <p>This bulletin applies to vehicles built on or before May 7, 2008. One of the two side tailgate check cables may not be properly tensioned. This condition may cause the appearance that the tailgate cables are of unequal lengths. The repair procedure involves setting the loose/longer in appearance cable firmly into its seat.</p>
23-046-07 10/30/07	'06-'08 (DR/D1/DC/DH)	<p><i>Repair of etched paint.</i></p> <p>This bulletin involves evaluating the paint condition on all horizontal panels for etching. If the problem exists, the bulletin describes the proper repair procedure using sanding/buffing techniques or spot paint refinishing.</p>

CATEGORY 24 HEATING & A/C

<u>TSB #</u>	<u>MODELS</u>	<u>SUBJECT/DESCRIPTION</u>
24-009-02 10/28/02	'90-'04 All Chrysler Group products using R-134A refrigerant	<i>A/C system leak detection.</i> Vehicles from the factory no longer have leak detection dye in the A/C system. To determine the source of a R-134a leak, a leak tracer dye has to be injected into the A/C system.
24-003-03 5/23/03	'90-'04 All Chrysler Group products	<i>A/C system additives.</i> The use of A/C system sealers may result in damage to A/C refrigerant recovery/evacuation/recharging equipment and/or A/C system components. Many federal, state/provincial and local regulations prohibit the recharge of A/C systems with known leaks. DaimlerChrysler recommends the detection of A/C system leaks through the use of approved leak detectors available through Pentastar Service Equipment (PSE) and fluorescent leak detection dyes available through Mopar Parts. Vehicles found with A/C system sealers should be treated as contaminated and replacement of the entire A/C refrigerant system is recommended.
24-004-03 6/13/03	'03 (DR)	<i>Defrost/door inoperative.</i> The defrost door may break at the pivot shaft causing inadequate travel. The system may not completely close, causing a lack of air discharge out the floor vents and full discharge from the defrost outlet. This may be caused by a broken actuator stop on the heater A/C (HVAC) housing. The bulletin describes the repair procedure for replacing the defrost door and the lower half of the heater/AC housing.
24-021-05 12/16/05	'06 (DR)	<i>Mega Cab – lack of air flow from rear seat heat duct.</i> This bulletin applies to 2006 Ram Truck Mega Cab built between 8/29/2005 and 8/31/2005. The rear seat actuator rod could become disconnected from the actuator lever, causing the rear seat heater door to become inoperative. This bulletin involves replacing the rear seat heat duct actuator lever.
24-006-06 8/9/06	'02-'07 (DR)	<i>A/C cooling coil odor.</i> This bulletin involves inspecting for leaves and other foreign material, cleaning, and treating the cooling coil and housing. Some vehicle operators may experience a musty odor from the A/C system, primarily at start up in hot and humid climates. This odor may be the result of microbial growth on the cooling coil. During normal A/C system operation, condensation, bacteria and fungi growth begins and odor results. If the operator describes, or the technician experiences, a musty odor when operating the A/C system, perform the appropriate repair procedure based on the vehicle model.

1997-2009 RECALL NOTICES

OUTER DASH SILENCER PAD AND HEAT SHIELD SAFETY RECALL (737)

The outer dash silencer pad, on the below listed vehicles, may contact the exhaust pipe. Under certain operating conditions, the exhaust pipe may become not enough to over heat or ignite the silencer pad. To correct this condition, part of the silencer pad must be removed and a heat shield must be added to the exhaust pipe.

Models: 1997 model year Dodge Ram (BR) trucks equipped with a 5.9L diesel engine ('D' in the 8th VIN Position) built at the:

- Saltillo Assembly Plant ('G' in the 11th VIN Position) from March 7, 1997 through May 15, 1997
- St. Louis North Assembly Plant ('J' in the 11th VIN Position) from March 15, 1997 through May 16, 1997
- Lago Alberto Assembly Plant ('M' in the 11th VIN Position) from March 18, 1997 through May 15, 1997

The service/repair procedure involves removal of a portion of the silencer pad and the installation of heat resistant foil tape to the remainder of the silencer pad and the installation of a heat shield onto the exhaust pipe.

IGNITION SWITCH WIRING RECALL (875)

The ignition switch and/or steering column wiring may overheat when the blower motor is operated at high speed for an extended period of time. This can cause stalling, loss of blower motor or power window operation, ABS or airbag lamp illumination or a steering column/instrument panel fire.

The vehicles involved in the recall have a vehicle identification number as follows:

- Warren ("S" in the 11th VIN position) through April 4, 1996;
- St. Louis ("J" in the 11th VIN position) through March 23, 1996;
- Lago Alberto ("M" in the 11th VIN position) through April 14, 1996;
- Saltillo ("G" in the 11th VIN position) through April 14, 1996.

The repair involves installing a blower motor relay and overlay harness to remove the blower motor circuit from the ignition switch. In addition, the ignition switch and electrical connector must be inspected for damage and replaced if necessary.

Note to TDR subscribers: the primary parts package for this repair does not include a replacement ignition switch assembly, but rather provides a blower motor relay and overlay harness; if necessary, an ignition switch wiring pigtail; clips, screws, washers, etc., to install the blower motor relay.

During the repair the ignition switch and associated connectors are to be inspected. The technician is instructed to look for indications of melting or deformation, specifically at terminals four and five. Very few vehicles are expected to require ignition switch replacement.

Editor's note: The title of the recall, "Ignition Switch Recall 875" leads one to conclude that the recall is to replace the ignition switch assembly. As summarized from the dealer service instructions, the recall has very little to do with the ignition switch, but rather is focused on adding a relay to the blower motor circuit. The moral of the story – don't jump to conclusions based on the title of a memo and be sure additional trailer light wiring and accessories that are added to your vehicle are on a separate relay-switched circuit.

FUEL TRANSFER PUMP RECALL (878)

The fuel transfer (lift) pump on about 12,000 24-valve vehicles may be susceptible to premature internal armature shaft bushing wear. Failure of the shaft bushing typically causes a no-start condition. To correct the problem, the supplier of the fuel transfer pump (Federal Mogul) has returned to the original sintered iron bushing design.

The suspect vehicles have a Cummins engine serial number sequence that falls between 56662576 and 56671920. These engines were installed at the DaimlerChrysler assembly plant in St. Louis from 12/3/99 to 1/18/00; Lago Alberto from 12/2/99 to 2/1/00; Satillo from 12/2/99 to 2/1/00.

The replacement involves removal of the starter motor to gain access to the electronic transfer pump. Remove and install a replacement pump. Reinstall the starter and check for leaks and proper operation. The flat rate time schedule for replacement is approximately one hour.

THROTTLE CONTROL CABLE AND THROTTLE LINKAGE REPLACEMENT SAFETY RECALL (970)

DaimlerChrysler Corporation has determined that a defect, which relates to motor vehicle safety, exists in some 1994 through 1996 model year Dodge Trucks equipped with a Cummins Turbo Diesel engine (identified by a "C" in the eighth position of the VIN).

The throttle control cable on your Ram truck may fray and eventually break. A frayed throttle control cable may not allow the throttle to return to the idle position.

In addition, the throttle control linkage joints may corrode and cause the throttle to bind or stick.

Either of the above conditions could increase the truck's stopping distance and cause an accident without warning.

DaimlerChrysler will repair your truck free of charge (parts and labor). To do this, your dealer will replace your truck's throttle control cable and throttle linkage. The work will take about 1.0 hour to complete. The service/repair procedure involves removal of the throttle control cable, throttle linkage rod ends and linkage ball studs as all of these parts are replaced. Detailed removal and reinstallation instructions are provided to the dealership (reference Safety Recall 970).

**UPPER CONTROL ARM FASTENERS
(Recall 955)**

2001 BR/BE Ram Truck Quad Cab manufactured in July 2000.

The upper control arms attached with cadmium coated nuts can cause the bolts to stretch due to the application of a higher than specified clamp load. Breakage of the upper control arm fasteners could cause the axle to rotate forward under braking conditions. This rotation could twist the steering linkage and possibly separate the brake lines, increasing the risk of a crash. Dealers will replace the upper control arm bolts and nuts.

**REAR AXLE SPACER PLATE
(Recall 966)**

2001 (BR/BE) Dodge Ram Truck Quad Cab equipped with a camper package and overload springs manufactured in July 2000.

The rear axle spacer plate could lead to deformation of the upper spring plate during assembly of the axle to the vehicle resulting a soft joint. The soft joint could cause the rear axle U-bolts to lose clamp load, resulting in displacement of the rear axle and a loss of vehicle control. This could increase the risk of a crash. Dealers will remove the spacer plates and the spring plates will be replaced.

**THROTTLE CABLE
(Recall 970)**

1994-1996 (BR/BE) Dodge Ram Truck with diesel engine manufactured from July 1993 to July 1996.

On certain pickup trucks, the throttle cable could unravel (fray) or break, resulting in a loss of throttle control. A throttle that does not return to idle could result in unexpected acceleration, increasing the risk of a crash. Dealers will inspect and replace the throttle cable and upper bell crank lever.

**BRAKE HOSE/ABS SENSOR WIRE
ASSEMBLY CLEARANCE
(Recall 971)**

2000 (BR/BE) Dodge Ram Truck with ABS manufactured from July 1999 To September 1999.

Some vehicles may have inadequate clearance between the front tire/wheel and the brake hose/ABS sensor wire assembly. During full lock turns, it is possible for the tire or wheel to contact the brake hose/ABS sensor wire assembly. This could ultimately result in wire damage and/or a hole in the brake line, affecting brake effectiveness, increasing the risk of a crash. Dealers will replace the front brake hose assemblies, and the ABS sensor wire will be inspected and replaced if necessary.

**CLOCKSPRING
(Recall 982)**

2001 (BR/BE) Dodge Ram Truck manufactured from May 2000 To October 2000.

Sound deadener material internal to the clockspring could become detached from the clockspring cover and housing. When this occurs, the material could interfere with the clockspring ribbon and cause an open circuit. The driver air bag system will become disabled and the air bag warning lamp will illuminate on the instrument panel. Dealers will replace the clockspring assembly.

**CUSTOMER SATISFACTION
NOTIFICATION NO. C44
TRANSMISSION COOLER LINE**

Date: February 2004
Models: '03-'04 (DR)

This notification applies only to trucks equipped with a 5.9 liter Cummins diesel engine (sales code ETC or ETH) and an automatic transmission (sales code DG8 or DGP) built through November 24, 2003. The transmission cooler line on about 97,000 of the above vehicles can transmit high pressure pulses when the vehicle is operated at heavy loads. These pulses may cause the engine-mounted transmission cooler to crack and leak fluid which could result in significant transmission damage.

Repair: The transmission cooler line must be replaced on all involved vehicles. In addition, the engine-mounted transmission cooler must be inspected and replaced if necessary.

**CUSTOMER SATISFACTION
NOTIFICATION NO. C42
POWERTRAIN CONTROL
MODULE CONNECTORS**

Date: February 2004
Models: '03 (DR)

This notification applies only to trucks equipped with a 5.9 liter Cummins diesel engine (sales code ETC or ETH) and an automatic transmission (sales code DGP or DG8) built through July 9, 2003. The Powertrain Control Module (PCM) electrical connectors on about 70,000 of the above trucks may allow water to enter into the connectors. Water and the resulting corrosion in a PCM connector can cause the speed control and/or transmission overdrive function to become inoperative.

Repair: The three electrical connectors on the PCM must be removed and inspected for corrosion. If no corrosion is found, the connectors must be sealed by installing rubber O-rings onto the harness connectors.

If corrosion is found in the connector, the transmission wiring harness and PCM must be replaced.
CUSTOMER SATISFACTION NOTIFICATION E10
FRONT SUSPENSION COIL SPRINGS

Date: July 2005
Models: '05 (DH) Dodge Ram 3500 4x2 Pickup Truck

This notification applies only to the above vehicles built through May 27, 2005. Incorrect front coil springs may have been installed on about 8,100 of the above trucks' front suspension. This may cause the front suspension to bottom out prematurely, which can reduce ride quality.

Repair: Both front suspension coil springs must be replaced.

**SAFETY RECALL E17
OUT-OF-PARK ALARM SYSTEM**

Date: March 2006
Models: '03 – '04 (DR)
'05 (DH)

This recall applies only to the vehicles equipped with a 5.9L diesel engine (6 or C in the eighth VIN Position) and an automatic transmission (sales code DGP or DG8). In certain circumstances when a driver has not placed the shifter lever fully into the "Park" position and leaves the engine running, the vehicle may unexpectedly move rearward after seeming to be stable. Unintended rearward movement of a vehicle could injure those in and/or near the vehicle.

Repair: An Out-of-Park alarm system must be installed on the vehicle. The alarm system will beep the horn and flash the headlamps and shift indicator if a driver tries to exit a running vehicle without fully placing the shifter into the "Park" position.

**SAFETY RECALL F05
ANTILOCK BRAKE SYSTEM CONTROL MODULE**

Date: July 2006
Models: '06 (D1) Dodge Ram Pickup (3500 Series)
'06 (DH) Dodge Ram Pickup (1500 Mega Cab
and 2500 Series)

This recall applies only to the above vehicles equipped with a four-wheel Antilock Brake System (sales code BGK or BRT) built from September 12, 2005 through December 11, 2005. The Antilock Brake System (ABS) control module on about 37,900 of the above vehicles may cause the rear brakes to lock up during certain braking conditions. This could result in a loss of vehicle control and cause a crash without warning.

Repair: The ABS control module must be replaced and initialized with the StarSCAN tool.

**CUSTOMER SATISFACTION NOTIFICATION F19
ROLL-OVER VALVE VENT HOSES**

Date: June 2006
Models: '06 (DH) Dodge Ram 2500 Pickup and
Cab-Chassis
'06 (D1) Dodge Ram 3500 Pickup and
Cab-Chassis

This notification applies only to the above vehicles equipped with a 5.9L diesel engine (C in the eighth VIN position) built through February 1, 2006. The roll-over valves on about 69,300 of the vehicles may allow water to enter into the fuel tank. Excessive water in the fuel can damage the injection pump and/or injectors if the engine is off for an extended period of time.

Repair: A vent hose must be installed at each tank roll-over valve (ROV). The fuel system must be inspected for excessive water content. If excessive water is found, the water must be removed and the fuel filter must be replaced.

**EMISSIONS RECALL G30
REPLACE OXYGEN SENSOR MODULE
AND REPROGRAM ECM**

Date: October 2007

Models: '07 – '08 (DH/D1) Dodge Ram 2500/3500 Pickup Truck

This notification applies only to the above vehicles equipped with a 6.7-liter diesel engine built through August 20, 2007. The on-board diagnostic (OBD) system on about 74,000 of the above vehicles may not detect a failed oxygen sensor or illuminate the malfunction indicator light (MIL) as required. In addition, the OBD system may cause these trucks to fail an inspection maintenance test and may not store mileage as required for certain transmission faults.

Repair: The oxygen sensor module must be replaced and the engine control module (ECM) must be reprogrammed (flashed). The new software will also improve vehicle drivability and reduce the potential for exhaust soot accumulation in the vehicle's particulate filter. The recalibration of the ECM updates and supersedes TSB 18-033-07 Revision B, dated 6/28/07 (see page 63 for details).

**EMISSIONS RECALL H31
VECI LABEL**

Date: October 2008

Models: '08 (D1) Dodge Ram 3500 Truck Cab and Chassis

An incorrect Vehicle Emission Control Information (VECI) label was inadvertently installed on about 60 of the above vehicles. The original VECI label does not include the required information for vehicles built without a pickup box.

Repair: A new VECI label must be installed over the vehicle's original VECI label.

**CUSTOMER SATISFACTION NOTIFICATION E10
FRONT SUSPENSION COIL SPRINGS**

Date: July 2005

Models: '05 (DH) Dodge Ram 3500 4x2 Pickup Truck

This notification applies only to the above vehicles built through May 27, 2005. Incorrect front coil springs may have been installed on about 8,100 of the above trucks' front suspension. This may cause the front suspension to bottom out prematurely, which can reduce ride quality.

Repair: Both front suspension coil springs must be replaced.

**SAFETY RECALL H34
DASH SILENCER PAD**

Date: January 2009

Models: '07 – '08 (DH, D1, DC, DM)

The dash silencer pad on about 110,000 vehicles, built with a Cummins 6.7-liter diesel engine through 11/5/07, may sag and contact the exhaust gas recirculation (EGR) cooler. This may cause the dash silencer to locally overheat and cause an underhood fire without warning.

Repair: All vehicles must have a dash silencer pad support bracket installed.

**SAFETY RECALL H36
STEERING DRAG LINK INNER JOINT
AND DAMPER BRACKET**

Date: May 2009

Models: '08 – '09 (DH/D1) 2500/3500 series or 1500 Mega Cab (4x4 only)

'08 – '09 (DC) 3500 series Cab Chassis

This recall applies only to the above vehicles built from February 19, 2008 through October 30, 2008.

The steering drag link inner joint on about 32,700 of the above vehicles may fracture under certain driving conditions. This could result in a loss of steering control and cause a crash without warning.

Also the steering damper bracket at the tie rod tube may loosen. This could allow the bracket to slide on the tube and may cause increased vehicle turning radius.

Repair: The drag link inner joint must be replaced and the steering damper bracket must be inspected and replaced, if required.

**SAFETY RECALL H46
MOPAR STEERING LINKAGE**

Date: May 2009

Models: '03 – '04 (DR) 2500/3500 series 4x4
'05 (DH) 2500/3500 series 4x4
'06 – '09 (DH) 2500/3500 series or 1500 Mega Cab 4x4
'06 – '09 (D1) 3500 series 4x4
'07 – '09 (DC) 3500 series Cab Chassis

This recall only applies to vehicles that had certain Mopar service parts steering components installed.

During a prior service appointment, a Mopar service parts steering linkage was installed on about 13,900 of the above vehicles. The drag link inner joint may fracture under certain driving conditions. This could result in a loss of steering control and cause a crash without warning.

Also, the steering damper bracket at the tie rod tube may loosen. This could allow the bracket to slide on the tube and may cause increased vehicle turning radius.

Repair: The steering linkage must be inspected and some steering linkage components may need to be replaced.

**CALIFORNIA EMISSIONS RECALL K01
REPROGRAM ECM—OBD READINESS**

Date: May 2010

Models: '03 (DR) Dodge Ram 2500/3500 Pickup Truck
'06-'07 (DH/D1) Dodge Ram 2500/3500 Pickup
Truck: '07 (DC) Dodge Ram 3500 Cab Chassis

This recall applies only to the above vehicles equipped with a 5.9-liter diesel engine (sales codes ETC and ETH) and a California emission control system (sales code NAE). And to above vehicles equipped with a 6.7-liter diesel engine (sales code ETJ) and a California emission control system (sales code NAE) built through January 5, 2007.

The Engine Control Module (ECM) on the above vehicles may fail to accurately report diagnostic system information with some generic scan tools. This may cause the vehicle to be rejected or fail an Inspection/Maintenance Test (also known as a Smog Check).

Repair: The Engine control Module (ECM) must be reprogrammed (flashed).

**EMISSIONS RECALL J35
REPROGRAM ECM—REGENERATION STRATEGY**

Date: April 2010

Models: '07.5-'09 (DH/D1) Dodge Ram 2500/3500 Pickup Truck

This recall applies only to the above vehicles equipped with a 6.7-liter diesel engine (sale code ETJ). The Engine Control Module (ECM) software program on the above vehicles may cause illumination of the Malfunction Indicator Lamp (MIL) when no problem exists or under certain conditions allow heavy sooting of the turbocharger, exhaust gas recirculation valve and diesel particulate filter. Heavy sooting could damage emissions components and result in increased emissions.

Repair: The Engine Control Module must be reprogrammed (flashed). The bulletin describes the service procedure that the dealership technician is to follow. Using the dealership's scan tools, the time allowance for the reprogramming operation is less than one hour. As a part of the recall and ECM update the technician has to verify that the previous emissions recall, recall G30, October 2007, has been performed. The G30 recall contains software that must be installed to prevent damage to the ECM. There are no parts involved in the J35 recall notice.

TECHNICAL SERVICE BULLETINS ISSUED DURING 2010

CATEGORY 8 ELECTRICAL

<u>TSB #</u>	<u>MODELS</u>	<u>SUBJECT/DESCRIPTION</u>
08-004-10 3/2/10	'10 (D1) '10 (DJ) '09-'10 (DS)	<i>Radio video disable update.</i> This information-only bulletin describes the programming process used for allowing the front seat video option to be displayed if the vehicle is in park (automatic) or the emergency brake is on (manual).
09-018-10 7/29/10	'10 (DJ) '09-'10 (DS)	<i>Left turn signal on trailer may be inoperative.</i> When verifying trailer turn signal function prior to towing a trailer, the customer may experience a non functional left trailer turn signal. Check connector terminal number one. If there is silicone in the connector use a suitable tool, such as a straight blade Exacto knife, to scrape the silicone off the outside of the number one, left terminal.

CATEGORY 9 ENGINE

<u>TSB #</u>	<u>MODELS</u>	<u>SUBJECT/DESCRIPTION</u>
09-001-10 7/2/10	All diesel models	<i>Dust-out diagnosis for Cummins diesel engines.</i> This information-only bulletin involves proper inspection procedures to determine engine failure due to dust-out condition. Engines damaged due to the infiltration of dirt and/or debris through the air intake system are not warrantable.

CATEGORY 14 FUEL

<u>TSB #</u>	<u>MODELS</u>	<u>SUBJECT/DESCRIPTION</u>
14-001-10 2/2/10	'03-'09 (DH, D1)	<i>Electronic fuel control actuator (FCA) available for service/New diagnostics available for DTC P0251.</i> This bulletin applies to vehicles equipped with a 5.9-liter Cummins Turbo Diesel engine. Should the engine surge at idle or MIL illumination of code P0251 occur, follow the diagnostics in the service bulletin. The bulletin involves replacing the FCA with a revised Mopar part number 05183245AA.
14-002-10 2/11/10	'03-'09 (DH, D1) '07-'09 (DC)	<i>Heavy duty filtration – Mopar retrofit or add on parts available.</i> This bulletin applies to D1/DH/DR vehicles equipped with a 5.9-liter Cummins engine built from 2003 model year and D1/DH/DC vehicles equipped with a 6.7-liter Cummins engine built from 2007 model year. Several fuel system add-on or retrofit parts are available to enhance the filtering capability for customers exposing their vehicles to extremely dirty conditions. The description of parts available for Cummins diesel equipped vehicles is listed below: <div style="text-align: center; margin: 10px 0;">6.7-Liter Changes</div> <ul style="list-style-type: none"> • New fuel filter. This is the FS2 design. (5 and 10 micron filter-in-filter) fuel filter to retrofit earlier models (shell and element). 68061633AA – FS2 Element, fuel filter and shell. 68061634AA – FS2 Element, fuel filter – This filter to supersede the original 5183410AA filter when supplies are exhausted. <div style="text-align: center; margin: 10px 0;">6.7-Liter and 5.9-Liter Changes</div> <ul style="list-style-type: none"> • Fuel tank vent hose. 5.9 and 6.7 add-on or upgraded fuel tank vent hose kit with vent cap. 68068997AA – Fuel Tank Vent. Must be used in conjunction with the appropriate Fuel Tank Vent Kit listed below: 68051906AA – Kit, Severe Duty Fuel Tank Ventilation – DC 52 Gallon Tank 68061341AA – Kit, Severe Duty Fuel Tank Ventilation – D1/DH 35 Gallon Tank 68061342AA – Kit, Severe Duty Fuel Tank Ventilation – D1/DH 34 Gallon Tank <div style="text-align: center; margin: 10px 0;">5.9-Liter Changes</div> <ul style="list-style-type: none"> • 5.9 upgraded air filter. This filter is similar in design to the current 6.7-liter air filter. The part number is: 53034249AA – Element, Air Filter – 2003-2007 5.9-liter

CATEGORY 18**VEHICLE PERFORMANCE**

<u>TSB #</u>	<u>MODELS</u>	<u>SUBJECT/DESCRIPTION</u>
18-024-09 12/3/09 Rev. A	'07-'09 (D1, DH)	<p><i>Diagnostic and System improvements and improved air filter minder.</i></p> <p>This bulletin supersedes technical service bulletin 18-024-09, dated August 6, 2009. This bulletin applies to D1/DH vehicles equipped with a 6.7-liter Cummins engine built before May 5, 2009. This bulletin involves selectively erasing and reprogramming the engine control module (ECM) with new software. Pickup trucks equipped with a 6.7-liter Cummins diesel have a number of software improvements available. This latest bulletin will include:</p> <ul style="list-style-type: none"> • EGR valve cleaning cycle. • DPF "Snuffer" feature to expand DPF temperature controls during deSoot. • DPF "Super deSoot" feature to enhance the deSoot process. • Improved air filter minder detection. • Added turbo cleaning scan tool service procedure available through a diagnostic scan tool. This procedure is available with version 10.02 due out in December. • Many other enhancements.
18-016-10 4/30/10	'07-'08 (DH) '07-'08 (D1)	<p><i>CCN update required with J35 recall.</i></p> <p>This bulletin applies to '07 and '08 vehicles equipped with a Cummins 6.7-liter engine. This bulletin supersedes service bulletin 18-013-08 Rev. A, dated December 4, 2008. Many improvements have been addressed with the latest engine control module (ECM) software addressed in Recall J35. The cab compartment node (CCN) may require updating in conjunction with the Recall. This service bulletin discusses the procedure used to update the CCN.</p>
18-017-10 5/15/10	'06 (DH) 2500 pickup 5.9-liter '06 (D1) 3500 pickup 5.9-liter '07 ((DH) 2500 pickup 5.9-liter '07 (D1) 3500 pickup 5.9-liter '07 (DC) 3500 Cab/Chassis 6.7-liter	<p><i>The problem addressed with this bulletin is that the truck will not pass a Smog Check On-Board Diagnostic (OBD) Test or Inspection and Maintenance check up.</i></p> <p>This bulletin applies to 2006 and 2007 vehicles equipped with a 5.9-liter Cummins engine (sales code ETC or ETH) with Federal emissions (sales code NAA) built after January 1, 2006, or Cab Chassis equipped with a 6.7-liter Cummins engine (sales code ETJ) built prior to January 11, 2007. This bulletin supersedes service bulletin 18-038-09, dated December 19, 2009. This revised bulletin will cover federal emissions (EPA) certified vehicles only. Vehicles equipped with CARB (California) emissions have been removed and are addressed in Recall K01, dated May 2010.</p> <p>The instructions in the bulletin tell the technician how to selectively erase and reprogram the Engine Control Module (ECM) with new software.</p>
18-020-10 6/10/10	'07-'10 (DC) '08-'10 (DM)	<p><i>Engine systems and exhaust aftertreatment systems enhancements.</i></p> <p>Cab/Chassis trucks equipped with a 6.7-liter Cummins engine have a number of software improvements available. This latest service bulletin (which supersedes 18-038-06 and 18-001-09) will include improvements to prevent erroneous Malfunction Indicator Lamp (MIL) illumination:</p> <ul style="list-style-type: none"> • P000F – Fuel System Over Pressure Relief Valve Activated • P0087 – Fuel Rail Pressure Too Low • P0106 – Manifold Absolute Pressure Sensor Performance • P0191 – Fuel Rail Pressure Sensor circuit Performance • P1011 – Fuel Pump Delivery Pressure Too Low • P2299 – Brake Pedal Position/Accelerator Pedal Position Incompatible • P2262 – Turbocharger Boost Pressure Not Detected – Mechanical <p>The bulletin involves selectively erasing and reprogramming the ECM.</p>

CATEGORY 19 FRONT SUSPENSION

<u>TSB #</u>	<u>MODELS</u>	<u>SUBJECT/DESCRIPTION</u>
19-002-10 1/23/10	'08-'09 (DM)	<i>Steering wander.</i> While traveling on a straight stretch of highway, a customer may feel the need to provide steering input to correct a vehicle wander condition. This bulletin applies to 4x2 vehicles built before August 8, 2009. This bulletin involves inspection or replacement of suspension components and revised caster specifications to improve road feel and correct a vehicle wander condition. If the vehicle operator describes the symptom/condition, perform the repair procedure.
19-004-10 5/29/10	'09 (DH)	<i>Steering Wander</i> While traveling on a straight stretch of highway, a customer may feel the need to provide steering input to correct a vehicle wander condition. This bulletin applies to 4x4 vehicles built before February 4, 2009. This bulletin involves installing an Intermediate steering shaft kit, part number 05165725AA.

CATEGORY 21 TRANSMISSION

<u>TSB #</u>	<u>MODELS</u>	<u>SUBJECT/DESCRIPTION</u>
21-003-10 5/12/10	'07 (DC)	<i>MIL illumination due to transmission related DTC P0711 or P0776.</i> This bulletin applies to 2007 3500 Chassis Cab models equipped with a 6.7-liter diesel engine and an AS68RC automatic transmission. This bulletin supersedes service bulletin 21-019-08, dated August 2, 2008. The customer may experience a malfunction indicator lamp (MIL) due to one or both of the following diagnostic trouble codes: P0711 – Transmission Temperature Sensor 1 Performance P0776 – Pressure Control Solenoid 3B Performance. This bulletin involves verifying software levels in the transmission control module (TCM) and the engine control module (ECM). Then, as necessary, selectively erasing and reprogramming the TCM and possibly the ECM.

CATEGORY 23 BODY

<u>TSB #</u>	<u>MODELS</u>	<u>SUBJECT/DESCRIPTION</u>
23-006-10 3/10/10	'10 (D2) '10 (DJ) '09 (DS)	<i>Hood creaking and squeaking sound.</i> The customer may experience a creaking and or squeaking sound from the hood area when turning the vehicle and or going over rough terrain. Inspect the hood, and if a squeaking or creaking sound is observed when pressing the front of the hood, perform the repair procedure, which calls for the addition of anti-squeak tape to the underside of the hood.

CATEGORY 25**EMISSIONS CONTROL**

<u>TSB #</u>	<u>MODELS</u>	<u>SUBJECT/DESCRIPTION</u>
25-001-09 10/20/09	'07-'09 (DH/D1)	<p><i>MIL Illumination due to P2000, P2A00 and/or P2A01.</i></p> <p>This bulletin supersedes service bulletin 18-035-08 dated September 13, 2008. This bulletin applies to vehicles equipped with a 6.7-liter Cummins diesel engine. The customer may experience MIL illumination. Further investigation by the technician may find one or more of the following DTC(s) present:</p> <ul style="list-style-type: none"> • P2000 – NOX Absorber Efficiency Below Threshold – Bank 1. • P2A00 – O2 Sensor 1/1 Circuit Performance. • P2A01 – O2 Sensor 1/2 Circuit Performance. <p>This bulletin involves verifying all TSB's related to high sooting issues have been properly addressed, inspecting both Oxygen (O2) sensors and either cleaning the sensors or replacing sensors, and installing an O2 Sensor Blanket/Shield on the exhaust pipe in the area of the front O2 sensor.</p>
25-001-10 7/9/10	'11 (DD) '11 (DP)	<p><i>Diesel exhaust fluid.</i></p> <p>This bulletin provides information regarding the diesel exhaust fluid (DEF) vehicle delivery fill guidelines. The vehicle is equipped with a "Low DEF" warning system that notifies the driver when the level of DEF drops below approximately 2.5 gallons. The warning system includes warning messages displayed by the EVIC and audible chimes. The first level warning displays the message "Refill DEF Engine Will Not Restart In XXX Miles". If the vehicle is driven too long with low DEF, the message "Refill DEF Engine Will Not Start" will be displayed. At that point, the engine will no longer restart if it is shut off. A minimum of 2.5 gallons of DEF will need to be added in order to be able to restart the engine.</p> <p>The following diagnostic trouble code may be displayed on a Diagnostic Scan Tool if the level of DEF was low.</p> <ul style="list-style-type: none"> • P203F – (Diesel Exhaust Fluid) Reductant Level Too Low When this code is set, the Powertrain Control Module (PCM) initiates a countdown that will inhibit an engine restart if the DEF system is not serviced within 500 miles. • P1C70 – SCR Error Detected – Engine Disabled When this code is set, the PCM commands the EVIC to display the "Refill DEF Engine Will Not Start" message. The message will continuously display when the counter reaches zero, and will be accompanied by a periodic chime. The engine will not start after it has been turned off unless up to 2.5 gallons of DEF is added to the tank. <p>DEF has a temperature dependent shelf life that shortens when exposed to elevated temperatures. As temperatures increase, the Urea in the DEF degrades. As the concentration degrades, the urea will become less effective at reducing NOx levels in the SCR catalyst. The following chart provides the approximate shelf life of DEF Versus temperature.</p>

Temperature	Estimated Useful Life
32°F (0°C)	Indefinite
50°F (10°C)	75 Years
68°F (20°C)	11 Years
86°F (30°C)	23 Months
95°F (35°C)	10 Months
104°F (40°C)	4 Months
122°F (50°C)	1 Month
140°F (60°C)	1 Week

2010 RECALL NOTICES

CALIFORNIA EMISSIONS RECALL K01 REPROGRAM ECM—OBD READINESS

Date: May 2010

Models: '03 (DR) Dodge Ram 2500/3500
'06-'07 (DH/D1) Dodge Ram 2500/3500
'07 (DC) Dodge Ram 3500 Cab Chassis

This recall applies only to the above vehicles equipped with a 5.9-liter diesel engine (sales codes ETC and ETH) and a California emission control system (sales code NAE). And to above vehicles equipped with a 6.7-liter diesel engine (sales code ETJ) and a California emission control system (sales code NAE) built through January 5, 2007.

The Engine Control Module (ECM) on the above vehicles may fail to accurately report diagnostic system information with some generic scan tools. This may cause the vehicle to be rejected or fail an Inspection/Maintenance Test (also known as a Smog Check).

Repair: The Engine control Module (ECM) must be reprogrammed (flashed).

EMISSIONS RECALL J35 REPROGRAM ECM—REGENERATION STRATEGY

Date: April 2010

Models: '07.5-'09 (DH/D1) Dodge Ram 2500/3500

This recall applies only to the above vehicles equipped with a 6.7-liter diesel engine (sale code ETJ). The Engine Control Module (ECM) software program on the above vehicles may cause illumination of the Malfunction Indicator Lamp (MIL) when no problem exists or under certain conditions allow heavy sooting of the turbocharger, exhaust gas recirculation valve and diesel particulate filter. Heavy sooting could damage emissions components and result in increased emissions.

Repair: The Engine Control Module must be reprogrammed (flashed). The bulletin describes the service procedure that the dealership technician is to follow. Using the dealership's scan tools, the time allowance for the reprogramming operation is less than one hour. As a part of the recall and ECM update the technician has to verify that the previous emissions recall, recall G30, October 2007, has been performed. The G30 recall contains software that must be installed to prevent damage to the ECM. There are no parts involved in the J35 recall notice.

www.techauthority.com

A HIGHLY RECOMMENDED RESOURCE

After a five-year absence of providing the service of listing new technical service bulletins for a given year, the folks at TechAuthority (www.techauthority.com) have reinstated this service feature. This is both good and not-so-good for the TDR audience.

How so?

Good: It allows the editor to list only those TSBs issued during a given year. This cuts down on my research and trims the page count as we don't have to print a compilation of TSBs that go on for three or four years.

Not-so-good: As the owner you only get to see a limited, one-year window of bulletins printed in the magazine. How can we make this news to you more agreeable? First, realize that a compilation of the yearly TSB updates is always available to you at the TDR's web site under the listing of "TSBs." Second, if you want to search the TSBs the old-fashioned way you can go back to your printed magazines and look specifically at our annual summaries (starting with a progression of four) at 66, 62, 58, 54, etc.

Elsewhere in the magazine I've already talked about TechAuthority as an outstanding resource for information. The value of the information available for your truck's VIN at www.techauthority.com far exceeds the TechAuthority subscription price of \$20. Using your VIN (I even tried a '97 truck's VIN and got the information), you'll be able to pull up and print all the TSBs and recall notices specific to your truck. And, as mentioned on page 53, you'll be able to scroll through the entire factory service manual for your vehicle.

Robert Patton
TDR Staff

TECHNICAL SERVICE BULLETINS ISSUED DURING 2011

CATEGORY 7 COOLING

<u>TSB #</u>	<u>MODELS</u>	<u>SUBJECT/DESCRIPTION</u>
07-003-10 9/9/10	'07-'10 DC/DM '11 (DD/DP)	<p><i>High coolant temperatures on vehicles equipped with snow plows.</i></p> <p>Customers that operate their vehicle with a snow plow attached to the vehicle may cause the airflow passing through the radiator to be disrupted resulting in higher than normal engine temperatures. The Cummins ECM is equipped with software that can fully engage the fan clutch to allow an increase of airflow through the radiator. Customers can initiate the fan clutch operation by performing the following button sequence:</p> <ul style="list-style-type: none"> • Turn the ignition key to the run position or start the truck. • Simultaneously press and release the Cruise Control "Cancel" button/lever and the "Exhaust Brake" button. Repeat this sequence four times within five seconds. The chime will sound twice as an audible indicator that the function is engaged. • To disable the function,s repeat the same procedure. The chime will sound four times as an audible indicator that the function is disengaged. <p>Note: '07-'09 truck engine ECMs were not equipped with the fan engagement software. These engines would require the latest software update (18-020-10) in order to have the fan-on capability.</p>
07-002-11 8/13/11	'11 DJ/D2	<p><i>Transmission cooler hose weepage.</i></p> <p>This bulletin applies to vehicles equipped with the Cummins engine and an automatic transmission built between September 20, 2010, and January 17, 2011. Some of the listed vehicles have been built with a transmission cooler hose that may experience fluid weepage. Inspect the upper transmission cooler hose ("Hot" side line that runs near the battery) for date code 2440. If the upper transmission cooler hose has date code 2440 on the hose, verify whether or not the hose was built between 21:14 – 23:16 (Time Stamp). The date code may be on the lower side of the hose. It may be necessary to use a mirror or rotate the hose.</p> <p>This bulletin involves inspecting the upper transmission cooler hose for a specific date code and time stamp. If found within the suspect range, the transmission cooler hose must be replaced.</p>
08-014-10 6/29/10	'10 D1/DJ	<p><i>Radio locks up.</i></p> <p>This bulletin applies to vehicles equipped with a radio with sales code REN, REZ. The problem may be that the radio will not change stations or frequency intermittently. The only function that will be available is volume control. The repair involves upgrading the software of the REN/REZ radio.</p>
08-026-10 Rev. A 12/18/10	'11 DD/DJ/DP/D2	<p><i>Park assist system for message clarity and false messages on 4x4 models.</i></p> <p>This bulletin applies to vehicles built with the Parksense Rear Park Assist (sales code XAA). Customers may not understand the EVIC message display "Blinded". This indicates that the Parksense Rear Park Assist sensors require cleaning. The EVIC flash will change the display to indicate "Clean Sensors". The EVIC may display the message "Press 4 Low" when a shift into 4x4 is not allowed. This message has no meaning on these vehicles. The EVIC flash will prevent this message from being displayed.</p> <p>This bulletin involves reprogramming the EVIC with new software.</p>

CATEGORY 8**ELECTRICAL**

<u>TSB #</u>	<u>MODELS</u>	<u>SUBJECT/DESCRIPTION</u>
08-028-10 Rev. A 11/2/10	'10 (DJ/DX/D2)	<p><i>RBZ radio software enhancements.</i></p> <p>This bulletin applies to vehicles built with a radio that has a sales code RBZ. The customer may experience one or more of the following problems:</p> <ul style="list-style-type: none"> • The display may appear to be dimly lit when in backup camera mode (if equipped). • Screen fonts too small or unclear. • Video playback, display too bright. • Audio playback, sound quality/frequency response could be improved. • Hands free call information does not display caller ID. • Bluetooth streaming audio information is incomplete. <p>The repair involves upgrading the software on the RBZ radio.</p>
08-001-11 Rev. A 3/5/11	'10-'11 (DJ/D2)	<p><i>Radio software enhancements.</i></p> <p>This bulletin applies to vehicles built with a radio/navigation units with sales codes RER, REW or REP. The problems experienced:</p> <ul style="list-style-type: none"> • The radio may lock up when a U-Connect call ends, this may cause battery drain. • Intermittent/no sound from audio system. • Repeated "Updating Channels" message when in satellite radio mode. • Losing Bluetooth connection intermittently and not displaying accurate caller ID information when using U-Connect. <p>This bulletin involves upgrading the software on the RER, REW, or REP Radio.</p>
08-003-11 Rev. B 3/17/11	'10-'11 (DD/DJ/DX/D2) '11 D2	<p><i>Exterior mirror courtesy lamps stay on longer than the customer desires.</i></p> <p>This bulletin involves checking the software version and, if necessary, flash reprogramming front door control modules with new software. This bulletin supersedes bulletin 08-003-11 revision A. This bulletin applies to vehicles equipped with exterior mirror courtesy lights (sales code LEC) built between January 1, 2010, and December 13, 2010.</p>
08-018-11 Rev. A 7/1/11	'10-'11 DJ/D2	<p><i>Static, squeal, no sound, or intermittent sound from speakers.</i></p> <p>This bulletin applies to DJ and D2 vehicles built between July 15, 2010, and November 30, 2010, equipped with 9 amplified speakers w/subwoofer (sales code RC3) or 9 amplified speakers (sales code RCZ). This bulletin also applies to DJ, and D2 vehicles built between July 15, 2010, and February 28, 2011, equipped with Premium I speakers (sales code RCK).</p> <p>The repair involves removing and replacing the amplifier.</p>
08-015-11 4/6/11	'11 DD/DJ/DP	<p><i>Flash: Intermittent no start or intermittent RKE function.</i></p> <p>This bulletin applies to DD, DJ, and DP vehicles built before April 7, 2011, equipped with remote keyless entry (sales code GXM). This bulletin involves flash reprogramming the wireless ignition node (WIN) with new software. The service flash corrects the following conditions</p> <ul style="list-style-type: none"> • Intermittent no start. • Intermittent RKE. <p>The above conditions may be caused by a software lockup in the module. The lockup condition may be cleared by removing the reinserting fuse M27. Flash reprogramming the WIN will correct these conditions.</p>
08-015-11 4/6/11	'11 DJ/D2/DD/DP	<p><i>Loss of communications with the hands free module (HFM).</i></p> <p>If there is a loss of the hands free module function the service bulletin involves performing a USB service flash of the hands free module.</p>
08-033-11 6/22/11	'11 DJ/D2/DD/DP	<p><i>Intermittent diagnostic trouble code P0201 – Fuel injector 1 circuit open/closed.</i></p> <p>This bulletin applies to a small number of vehicles equipped with the Cummins engine built between March 1, 2011, and March 11, 2011. Suspect vehicles may intermittently set DTC P0201 – Fuel injector 1 circuit open/closed. This bulletin involves replacing terminal number 26 from the powertrain control module (PCM) 76-way connector.</p>
08-049-11 8/12/11	'11 (DJ/D2/DD/DP/DX)	<p><i>Front overhead ambient light intermittent operation or inoperable.</i></p> <p>This bulletin applies to vehicles built between February 11, 2011, and March 9, 2011. If there is intermittent or no operation of the front overhead light this bulletin explains how to remove and repair the light.</p>

CATEGORY 9**ENGINE**

<u>TSB #</u>	<u>MODELS</u>	<u>SUBJECT/DESCRIPTION</u>
09-004-10 11/11/10	'11 DJ/D2/DD/DP	<i>Incorrect engine oil level indicator.</i> Cummins engines are equipped with an engine oil level indicator that identifies a "Safe" region on the end of the indicator. Some vehicles were equipped with an engine oil level indicator end that had "Add, Cold, Hot, and Do Not Add" increments on the end. These engine oil level indicators will need to be replaced. This bulletin involves inspecting the engine oil level indicator and replacing it if found to have an incorrect indicator end.

CATEGORY 13**FRAME & BUMPERS**

<u>TSB #</u>	<u>MODELS</u>	<u>SUBJECT/DESCRIPTION</u>
13-001-11 5/13/11	'10-'11 DJ/D2	<i>Front axle skid plate to oil pan contact.</i> This bulletin applies to vehicles equipped with 6.7-liter Cummins engine and TRX package (sales code AMW) built after September 1, 2009, and built prior to September 23, 2010. The front axle skid plate may contact the oil pan during extreme off road usage. The repair involves inspection of the oil pan and if necessary replacement of the front skid plate and oil pan.

CATEGORY 14**FUEL SYSTEM**

<u>TSB #</u>	<u>MODELS</u>	<u>SUBJECT/DESCRIPTION</u>
14-005-10 9/21/10	'10-'11 DJ/D2	<i>Fuel filler housing pops out of sheet metal.</i> This bulletin applies to vehicles equipped with a single wheel rear axle only built before August 9, 2010. The customer may notice that the fuel filler housing has popped out from the body on one side or the other. This bulletin involves removing the fuel filler housing to file some material off of the tabs that will not lock into place. If tab(s) are broken it will be necessary to replace the fuel filler housing and it still may be necessary to file some material off of the tab(s) that will not lock into place.

CATEGORY 18**VEHICLE PERFORMANCE**

<u>TSB #</u>	<u>MODELS</u>	<u>SUBJECT/DESCRIPTION</u>
18-004-11 Rev. A 2/18/11	'10 DJ/D2	<i>Diagnostic and system improvements.</i> This bulletin applies to trucks equipped with a 6.7-liter Cummins diesel. The bulletin describes a number of software improvements/enhancements that are available: <ul style="list-style-type: none"> • P046C – EGR position sensor performance • P051B – Crankcase pressure sensor circuit range/performance • P0101 – Mass air flow sensor "A" circuit performance • P2002 – Diesel particulate filter efficiency below threshold • P2196 – O2 sensor 1/1 out of range low • P245B – EGR cooler bypass status line intermittent • P2262 – Turbocharger boost pressure not detected – mechanical • P2271 – O2 sensor ½ out of range low This bulletin involves selectively erasing and reprogramming the engine control module (ECM) with new software.

CATEGORY 18**VEHICLE PERFORMANCE**

<u>TSB #</u>	<u>MODELS</u>	<u>SUBJECT/DESCRIPTION</u>
18-004-11 Rev. A 2/18/11	'10 DJ/D2	<p><i>Engine systems and PTO enhancements.</i></p> <p>This bulletin applies to vehicles equipped with a Cummins engine built before January 1, 2011. These cab chassis trucks have a number of software improvements available. This latest service bulletin will include:</p> <p>Improvements to prevent unnecessary malfunction indicator lamp (MIL) illumination for:</p> <ul style="list-style-type: none"> • P0524 – fault for low oil pressure, set during low ambient temperatures. • P051B – fault for crankcase pressure. <p>Enhanced diagnostics for:</p> <ul style="list-style-type: none"> • Variable geometry turbocharger. • Fuel level sensor. <p>Other updates:</p> <ul style="list-style-type: none"> • Low diesel exhaust fluid (DEF) level EVIC messaging strategy changes. • Diesel exhaust fluid (DEF) system tampering EVIC messaging strategy changes. • Oil change monitor – updated for easier reset (same basic procedure, easier to reset). • Scan tool display updates. • Enable mobile PTO capability. • Correct operation of remote PTO. • Correct EVIC messaging related to DEF level reporting. • System robustness improvements. • DEF tank level reporting erroneously at high DEF tank level. When DEF tank is overfilled, the EVIC may display low fluid level (20-22%). <p>This bulletin involves selectively erasing and reprogramming the engine control module (ECM) with new software.</p>

CATEGORY 19**STEERING**

<u>TSB #</u>	<u>MODELS</u>	<u>SUBJECT/DESCRIPTION</u>
19-001-11 Rev. A 8/9/11	'08-'10 DM '11 DP '10-'11 DJ/D2/DD '06-'09 DH/D1 '07-'09 DC '05 DH '03-'04 DR	<p><i>Tie rod ball stud housing alignment procedure.</i></p> <p>This bulletin describes the proper procedure to ensure parallel alignment of the right and left steering tie rod ball stud housings. The bulletin applies to 4x4 models of the 2500/3500 pickup truck and to all 3500/4500/5500 Cab Chassis trucks which have a solid front axle. The overview of this repair procedure: The right-to-left tie rod ball stud housings must be aligned parallel to one another and not exceed +/-3 degrees of combined parallelism. This procedure is required any time service is performed to either the tie rod or when performing a front end alignment or toe set procedure. Failure to properly perform the parallel alignment procedure may lead to tie rod damage</p>
19-003-11 2/2/11	'10-'11 DJ/D2 '11 DD	<p><i>Steering honk and/or groan sound during low speed parking lot maneuvers.</i></p> <p>This bulletin applies to vehicles equipped with 6.7-liter Cummins engine built prior to November 23,2010. The customer may experience a honk and/or groan sound coming from the steering system during low speed parking lot maneuvers. This bulletin involves inspecting and, if necessary, replacing the power steering gear. This bulletin applies to 4x4 models of the 2500/3500 pickup truck.</p>

CATEGORY 20**BODY**

<u>TSB #</u>	<u>MODELS</u>	<u>SUBJECT/DESCRIPTION</u>
23-024-11 7/12/11	'11 DD/DP '10-'11 DJ/D2 '09-'10 DM/DC '09 DH/D1	<i>Whistle and/or high pitch windnoise at door near windshield A-pillar.</i> This bulletin applies to vehicles built before April 18, 2011. The customer may experience whistle and/or high pitch windnoise at door near windshield A-pillar. This bulletin involves installing a foam stuffer block into door weatherstrip.

CATEGORY 25**EMISSIONS CONTROL**

<u>TSB #</u>	<u>MODELS</u>	<u>SUBJECT/DESCRIPTION</u>
25-002-10 9/22/10	'11 DD/DP	<i>Misassembled diesel exhaust fluid engine coolant control valve.</i> This bulletin applies to vehicles equipped with the Cummins engine built between March 3, 2010, and July 19, 2010. Some trucks may have been built with a DEF engine coolant control valve that may be internally misassembled which may not be able to completely shut the flow of coolant passing through the coolant tubes in the DEF tank. This allows the DEF temperature to rise above its normal operating range. DEF that has been exposed to elevated temperatures can cause the DEF to degrade. This bulletin involves replacing the diesel exhaust fluid (DEF) engine coolant con

2011 RECALL NOTICES

SAFETY RECALL K08 WIRELESS IGNITION NODE RECEIVER

Date: August 2010

Models: '10 (DJ) Ram Truck (2500)

'10 (D2) Ram Truck (3500)

This recall applies only to the above vehicles built at Saltillo Assembly Plant ("G" in the 11th VIN position) equipped with an automatic transmission from January 6, 2010 through February 16, 2010. This recall also affected other Chrysler vehicles.

The Wireless Ignition Node (WIN) receiver on about 8,900 of the above vehicles may experience a condition where the Frequency Operated Button Integrated Key (FOBIK) may be removed prior to placing the automatic transmission gear shift lever in the "PARK" position. This could result in unintended vehicle movement and cause a crash without warning.

To correct this condition, the Wireless Ignition Node receiver must be inspected and replaced if necessary. The new WIN must be programmed and all FOBIK transponders must be programmed so they are able to interface with the new WIN receiver.

CUSTOMER SATISFACTION NOTIFICATION K17 REPROGRAM HVAC CONTROL HEAD AND INSPECT/REPLACE ACTUATORS

Date: September 29, 2010

Models: '10 (DJ) Ram Truck (2500)

'10 (D2) Ram Truck (3500)

This recall applies only to the above vehicles built through May 22, 2010

The HVAC mode door actuator gears on about 52,000 of the above vehicles may break and result in the inability to fully control the HVAC functions.

To correct this condition, all involved vehicles must have updated HVAC control head software installed and the mode door actuators must be tested and replaced as required.

SAFETY RECALL K28 LEFT TIE ROD END

Date: February 2011

Models: '08-'10 (DM) Ram Truck (4500/5500) Cab/Chassis

'11 (DP) Ram Truck (4500/5500) Cab/Chassis

This recall applies only to the above vehicles built through September 02, 2010.

The left outer tie rod end on about 15,500 of the above vehicles may fracture due to a misalignment condition. Under certain driving conditions, this may lead to a weakening and eventual fracture of the left outer tie rod ball stud. A fractured tie rod end could cause a loss of directional stability and a crash without warning.

The left outer tie rod end must be replaced, toe-in must be set, and the tie rod ends must be aligned.

CUSTOMER SATISFACTION NOTIFICATION L14 REPROGRAM HVAC CONTROL HEAD

Date: April 12, 2011

Models: '10 (D2) Ram Truck (2500)

'10 (DJ) Ram Truck (3500)

This notification applies only to the above vehicles built with Manual Temperature Control (MTC) from March 18, 2010, through June 24, 2010.

The Heating, Ventilation, and Air Conditioning (HVAC) control head software on about 10,330 of the above vehicles may cause the mode door actuator gears to make noise and/or break. This could cause the inability to fully control the HVAC functions.

To correct this condition, the HVAC control head must be reprogrammed with new software.

**SAFETY RECALL K33
POWER STEERING RESERVOIR CAP**

Date: February 1, 2011

Models: '10-'11 (DC/DM/DJ/D2/DD/DP) Ram Truck

This recall applies only to the above vehicles equipped with a Cummins engine built at the Saltillo Assembly Plant ("G" in the 11th VIN Position) through October 05, 2010.

The power steering reservoir cap on about 11,300 of the above vehicles may cause excessive vent pressure levels in the power steering/hydraulic brake booster system. This may cause the vehicle to have brake lights that remain illuminated for an extended period of time after the brake pedal has been released. Brake lights that are slow to turn off could increase the risk of a crash.

To correct this condition, the power steering reservoir cap must be replaced.

**EMISSIONS RECALL K34
REPROGRAM ECM – EGR DIAGNOSTIC**

Date: February 8, 2011

Models: '10 (DJ/D2) Ram Truck (2500/3500) Pickup

This recall applies only to the above vehicles equipped with a Cummins engine built from October 1, 2009, through June 24, 2010.

The Engine Control Module (ECM) on about 1193 of the above vehicles may have been built with a software error that prevents the EGR cooler bypass valve diagnostic from running after detecting a pending fault, disabling deNOx without illuminating the MIL. This may cause the vehicle's exhaust emissions to exceed the allowable limit for oxides of nitrogen.

To correct this condition, the Engine Control Module (ECM) must be reprogrammed (flashed).

**CUSTOMER SATISFACTION NOTIFICATION L03
DOOR LATCHES**

Date: March 2011

Models: '11 (D2) Ram Truck (3500) Pick up
'11 (DD) Ram Truck (3500) Cab/Chassis
'11 (DJ) Ram Truck (2500) Pick up
'11 (DP) Ram Truck (4500/5500) Cab/Chassis

This notification applies only to the above vehicles equipped with power door locks (sales code JPB) built from July 01, 2010, through November 23, 2010.

The right front door latch, right rear door latch and/or swing gate latch on about 35,000 of the above vehicles may develop a ratcheting sound while using the power door locks.

The right front door latch and right rear door latch must be inspected and replaced if necessary.

TECHNICAL SERVICE BULLETINS ISSUED DURING 2012

CATEGORY 8 ELECTRICAL

TSB #	MODELS	SUBJECT/DESCRIPTION
08-011-12 2/8/102	'12 DJ/DD/D2/DP	<p><i>Radio anti-theft codes.</i></p> <p>Starting in model year 2012 radios will come equipped with an anti-theft feature. Once a radio is installed in a vehicle, it learns the vehicle's VIN and cannot be used in another vehicle unless an anti-theft code is applied.</p>

This "information only" TSB tells the dealer how to obtain the radio's anti-theft code. This bulletin also supersedes bulletin 08-051-11 dated 8/20/11 by providing updated service information.

Editor's Comments – Radios

Have you tried to restore a car with a "coded" radio? I've been playing with BMW coded radios from cars that are now 25 years old. What a pain in the tail.

This brings several questions to mind: In today's market, where a replacement can be purchased for \$69, does theft occur that often? Why is Chrysler 30 years behind the theft code thing? What implications will this have to Joe-second-owner/Joe-restoration who does not have TSB 08-011-12 to tell him how the dealer can unlock a code?

Geez.

CATEGORY 9 ENGINE

TSB #	MODELS	SUBJECT/DESCRIPTION
19-001-11 Rev. A 8/9/11	'08-'10 DM '11 DP '10-'11 DJ/D2/DD '06-'09 DH/D1 '07-'09 DC '05 DH '03-'04 DR	<p><i>Dust-out diagnosis for Cummins diesel engines.</i></p> <p>This "information only" bulletin involves proper inspection procedures to determine engine failure due to dust-out condition. Engines damaged due to the infiltration of dirt and/or debris through the air intake system are not warrantable.</p> <p>Engines that exhibit particular symptoms that may have been caused by improper air filtration and/or lack of proper maintenance. Some of these symptoms are listed below (not limited to):</p>

- Knocking
- Hard or no start
- Low power/poor performance
- Oil consumption
- Lower end bearing failure
- Broken rod
- Smoking
- Blow-by (rings not sealing)
- Oil on turbo (dust damage to seal/bearing)

This nine-page bulletin supersedes bulletin 09-001-10 dated 7/2/10 and gives the service network an easy to print/easy to follow diagnosis procedure. The highlights:

- Major mechanical damage can be caused by fuel, fuel injectors, up-rate kits or programmers. Inspect vehicle for any device that adds more power (fuel), which may damage the engine mechanically. Check for any aftermarket power enhancer box or downloader. Repairs performed on engines with failures caused by these devices do not qualify for warranty coverage.
- Inspect for aftermarket cold air performance air filter housing, duct work and/or air filter type (wrong style air filter which may be used in a stock air filter box).
- Vehicles with extremely large amounts of visible dirt accumulation are candidates for dust out damage if not properly maintained or use of improper filters. Engines with excessive cylinder and/or ring wear will consume excess oil. Look for oil spilled near filler on valve cover which may indicate oil has been (or is) added often.

As mentioned, the bulletin continues for nine-pages that show the cause/effect from lack of proper air filtration.

CATEGORY 9 ENGINE

Editor's Comments – Dust Out

If you spend a day answering the tech line at Geno's Garage you would be surprised at the number of phone calls asking about air filters and cold air boxes.

The staffs' answer: If you value your rights to warranty consideration, leave the air intake system alone.

Prior to this TSB there was the 09-001-10 TSB. Prior to these TSBs there was the "K&N story," the short version being that testing was done on this filter in 1999 by Dodge and Cummins. Prior to the test, K&N was the number two selling item at Geno's Garage. After the test, K&N filters were no longer offered by Geno's. However, folks still want to know more as aftermarket advertising does an admirable job of selling these parts. So, if you need to help control exhaust gas temperatures due to the high horsepower you are making, you should consider a cold air box and a multi-layer filter. The Geno's folks do sell a multi-layer filter. See TDR Issue 56, page 150 and Issue 59, page 130 for the cold air box story. See TDR Issue 34, page 105 and Issue 77, page 56, for the K&N story.

CATEGORY 14 FUEL SYSTEM

<u>TSB #</u>	<u>MODELS</u>	<u>SUBJECT/DESCRIPTION</u>
14-004-11 4/1/11	'03-'09 (D1/DH/DR) '07-'10 (DC)	<p><i>Heavy duty filtration – Mopar retrofit or add on parts available.</i></p> <p>This bulletin applies to D1/DH/DR vehicles equipped with a 5.9-liter Cummins engine built from 2003 model year and D1/DH/DC vehicles equipped with a 6.7-liter Cummins engine built from 2007.5 model year. Several fuel system add-on or retrofit parts are available to enhance the filtering capability for customers exposing their vehicles to extremely dirty conditions. The description of parts available for Cummins diesel equipped vehicles is listed below:</p> <p style="text-align: center;">5.9-Liter Changes – Air Filter</p> <ul style="list-style-type: none">• 5.9 upgraded air filter. This filter is similar in design to the current 6.7-liter air filter. The part number is: 53034249AA – Element, Air Filter – 2003-2007 5.9-liter <p style="text-align: center;">6.7-Liter Changes – Fuel Filter</p> <ul style="list-style-type: none">• New fuel filter. This is the FS2 design. (5 and 10 micron filter-in-filter) fuel filter to retrofit earlier models (shell and element). 68061633AA – FS2 Element, fuel filter and shell. 68061634AA – FS2 Element, fuel filter – This filter to supersede the original 5183410AA filter when supplies are exhausted. <p style="text-align: center;">6.7-Liter and 5.9-Liter Changes – Tank Ventilation</p> <ul style="list-style-type: none">• Fuel tank vent hose. 5.9 and 6.7 add-on or upgraded fuel tank vent hose kit with vent cap. 68068997AA – Fuel Tank Vent (\$66.10). Must be used in conjunction with the appropriate Fuel Tank Vent Kit listed below: 68051906AA – Kit, Severe Duty Fuel Tank Ventilation – DC 52 Gallon Tank (\$32.95) 68061341AA – Kit, Severe Duty Fuel Tank Ventilation – D1/DH 35 Gallon Tank (\$58.85) 68061342AA – Kit, Severe Duty Fuel Tank Ventilation – D1/DH 34 Gallon Tank (\$63.20) <p style="text-align: center;">6.7-Liter and 5.9-Liter – Auxiliary Fuel Filter</p> <ul style="list-style-type: none">• Severe duty fuel filter kit. This kit supplies the owner with an auxiliary fuel filter, mounting bracket for under the frame installaiton, hoses, hardware and electrical connections to add another fuel filter to the truck. 68083851AA kit, '07-'12 Cab and Chassis 68083853AA kit, '04-'12 Pickup (2500/3500) 68026934AA wiring adaptor, for use with kit 6808353AA and in the model years '04.5-'07

Editor's Comments – HD filtration

This is one of those "been there, done that" TSBs. We discussed the merits of this TSB and specifically the "6.7-liter and 5.9-liter – Auxiliary Fuel filter" in last issue's magazine, Issue 77, pages 14-16.

In the cost analysis/conclusion part of the article, I closed by saying, "Ding, ding, ding, bottom line, what is the cost analysis?" The Mopar kit will cost about \$450. From last issue, my "Fool Transfer Pump/Boy Scout" project for the '05 to current trucks cost \$625.

"The Fool Transfer Pump/Boy Scout project gives you better filtration and a redundant pump for fuel supply. However, its installation requires removal of the fuel tank. Nonetheless, for my peace of mind, I'll spend the \$625 and do the extra labor for the fool solution that I presented in Issue 76. Your decision?"

A lot can happen in the 11 months from the beginning of a project to magazine-in-hand. However, I continue to stand behind my decision to use the redundant FASS "Platinum 08-95G" fuel transfer pump and filter as I wrote about in Issue 76, pages 16-21.

CATEGORY 19**VEHICLE PERFORMANCE**

<u>TSB #</u>	<u>MODELS</u>	<u>SUBJECT/DESCRIPTION</u>
18-004-11 Rev. B 12/21/11	'10 (DJ/D2)s	<p><i>Diagnostic and system improvements.</i></p> <p>This bulletin supersedes service bulletin 18-004-11 Rev. A, dated February 18, 2011. This bulletin applies to vehicles equipped with a 6.7-liter Cummins engine. The software flash provides a number of software improvements/enhancements. These include:</p> <ul style="list-style-type: none">• P049D – EGR control position exceeded learning limit• P2002 – Diesel particulate filter efficiency below threshold• P2195 – O2 sensor 1/1 out of range high• P2196 – O2 sensor 1/1 out of range low• P2270 – O2 sensor ½ out of range high• P2271 – O2 sensor ½ out of range low• P241A – O2 sensor 1/1 and ½ oxygen concentration mismatch• P2609 – Intake air heater system performance <p>The previous TSB had software improvements for:</p> <ul style="list-style-type: none">• P046C – EGR position sensor performance• P051B – Crankcase pressure sensor circuit range/performance• P0101 – Mass air flow sensor “A” circuit performance• P245B – EGR cooler bypass status line intermittent• P2262 – Turbocharger boost pressure not detected – mechanical <p>The bulletin involves selectively erasing and reprogramming the engine control module (ECM) with new software.</p>
18-045-11 10/19/11	All 6.7-liter diesel-equipped vehicles	<p><i>Cummins 6.7-liter Turbo Diesel common diagnostic process.</i></p> <p>This bulletin supersedes service bulletins 09-002-09 dated June 13, 2009; 09-003-09 dated December 2, 2009; and 11-001-09 dated July 23, 2009.</p> <p>This diagnostic process was developed for any drivability concern with the 6.7-liter engine. Non-drivability engine issues or engine cooling system issues are not in the scope of this process.</p> <p>The process begins by identifying the customer’s concern and applying it to one of the following symptoms:</p> <ul style="list-style-type: none">• MIL illumination• Engine cranks but does not start or starts and immediately stalls• Engine surges, bucks, runs rough – no MIL• Engine noise – no MIL• Excessive black smoke out exhaust – no MIL• Excessive white smoke out exhaust – no MIL• Excessive blue smoke out exhaust – no MIL <p>Once the data has been collected and analyzed, the diagnostic process can continue. The tests are designed to direct the service technician to the diagnostic path that leads to corrective actions that repair conditions that occur most frequently for that specific concern.</p>

CATEGORY 19**VEHICLE PERFORMANCE**

<u>TSB #</u>	<u>MODELS</u>	<u>SUBJECT/DESCRIPTION</u>
18-005-12 1/28/12	'11 (DD/DP)	<p><i>Engine systems and PTO enhancements.</i></p> <p>This bulletin supersedes service bulletin 18-029-11 dated December 17, 2011. Cab chassis trucks equipped with a 6.7-liter Cummins diesel have a number of software improvements available. This latest Service bulletin will include:</p> <p>Improvements to prevent unnecessary malfunction indicator lamp (MIL) illumination for:</p> <ul style="list-style-type: none">• P0524 – Engine oil pressure sensor circuit low• P051B – Crankcase pressure sensor circuit range/performance• P20EE – SCR NOx catalyst efficiency below threshold – Bank 1• U010E – Lost communication with diesel exhaust fluid control unit• P2609 – Intake air heater system performance• P061A – ETC level 2 torque performance• P1123 – Power take off system monitor control error• P2579 – Turbocharger speed sensor circuit performance <p>Enhanced diagnostics for:</p> <ul style="list-style-type: none">• Variable geometry turbocharger• Fuel level sensor• Misfire without MIL illumination <p>Other updates:</p> <ul style="list-style-type: none">• Low diesel exhaust fluid (DEF) level EVIC messaging strategy changes• Diesel Exhaust fluid (DEF) system tampering EVIC messaging strategy changes• Oil change monitor – updated for easier reset (same basic procedure, easier to reset)• Scan tool display updates• Enable mobile PTO capability• Correct operation of remote PTO• Correct EVIC messaging related to DEF level reporting• System robustness improvements• DEF tank level reporting erroneously at high DEF tank level. When DEF tank is overfilled, the EVIC may display low fluid level (20-22%). <p>This bulletin involves selectively erasing and reprogramming the engine control module (ECM) with new software.</p>
18-001-12 Rev A 1/28/12	'12 (DD/DP)	<p><i>Engine systems and PTO enhancements.</i></p> <p>This bulletin supersedes service bulletin 18.001/12, dated January 07, 2112. Cab chassis trucks equipped with a 6.7-liter Cummins diesel have a number of software improvements available. This latest service bulletin will include:</p> <p>Improvements to prevent unnecessary malfunction indicator lamp (MIL) illumination for:</p> <ul style="list-style-type: none">• P061A – ETC Level 2 Torque Performance• P20EE – ACR NOx Catalyst Efficiency Below Threshold – Bank 1• P229F – Aftertreatment NOx Sensor Circuit Performance – Bank 1 Sensor 2• P2609 – Intake Air Heater System Performance• P1123 – Power Take Off System Monitor Control Error• U010E – Lost Communication With Diesel Exhaust Fluid Control Unit <p>Enhanced Diagnostics For:</p> <ul style="list-style-type: none">• Selective Catalyst Reduction (SCR) efficiency diagnostic improvements. <p>Other Update:</p> <ul style="list-style-type: none">• Idle shutdown message on EVIC.• Turbo protection feature (Not displayed if vehicle is in park or no vehicle speed). Limits RPM at cold ambient to prevent turbo damage.• Scan tool display updates.• Correct operation of remote PTO.• System robustness improvements. <p>The bulletin involves selectively erasing and reprogramming the engine control module (ECM) with new software.</p>

CATEGORY 18**VEHICLE PERFORMANCE**

<u>TSB #</u>	<u>MODELS</u>	<u>SUBJECT/DESCRIPTION</u>
18-013-12 3/17/12	'12 (DJ/D2)	<p><i>Diagnostic and system improvements.</i></p> <p>This bulletin supersedes service bulletin 18-055-11, dated December 17, 2011. This bulletin involves selectively erasing and reprogramming the engine control module (ECM) with new software. The software package has improvements/enhancements available for the following DTC's:</p> <ul style="list-style-type: none">• P049D – EGR Control Position Exceeded Learning Limit• P2002 – Diesel Particulate Filter Efficiency Below Threshold• P2195 – O2 Sensor 1/1 Out of Range High• P2196 – O2 Sensor 1/1 Out of Range Low• P2170 – O2 Sensor 1/2 Out of Range High• P2171 – O2 Sensor 1/2 Out of Range Low• P241A – O2 Sensor 1/1 and 1/2 Oxygen Concentration Mismatch• P2609 – Intake Air Heater System Performance <p>Vehicles flashed to address the above codes should be driven and repair validated. If code(s) return, follow diagnostic procedures available in DealerCONNECT/TechCONNECT. The software also updates the ECU with other improvements:</p> <ul style="list-style-type: none">• Correct water in fuel (WIF) parameter• ScanTool may report a code as stored, even though the fault has been cleared by completing a significant number of drive cycles without a repeat occurrence.• Active codes not always displayed correctly.• Engine derate with IOD removed. This will help prevent turbo damage due to oil thickening in cold climate start up on new vehicles in transit.• Scan tool readiness reporting issues.• Other drivability enhancements.• EGR Valve cleaning and monitoring enhancements to help reduce occurrences of P049D.• Erroneous, brief brake lamp flash at key on.• Improve EVIC message regarding idle shut down.• Ability to read EGR valve gap an wiTECH
18-012-12 3/19/12	'11 (DJ/D2)	<p><i>Diagnostic and system improvements.</i></p> <p>This bulletin supersedes service bulletin 18-002-11 Rev. B, dated December 16, 2011. This bulletin involves selectively erasing and reprogramming the engine control module (ECM) with new software. The new software will have improvements/enhancements available for the following DTC's:</p> <ul style="list-style-type: none">• P0101 – Mass Air Flow Sensor "A" Circuit Performance• P2262 – Turbocharger Boost Pressure Not Detected – Mechanical• P2457 – Exhaust Gas Recirculation Cooling System Performance• P245B – EGR Cooler Bypass Status Line Intermittent• P049D – EGR Control Position Exceeded Learning Limit• P2195 – O2 Sensor 1/1 Out of Range High• P2196 – O2 Sensor 1/1 Out of Range Low• P2002 – Diesel Particulate Filter Efficiency Below Threshold (for high altitude failures)• P2270 – O2 Sensor 1/2 Out of Range High• P2271 – O2 Sensor 1/2 Out of Range Low• P241A – O2 Sensor 1/1 and 1/2 Oxygen Concentration Mismatch• P2609 – Intake Air Heater System Performance <p>Vehicles flashed to address the above codes should be driven and repair validated. If code(s) return, follow diagnostic procedures available in DealerCONNECT/TechCONNECT. The software also updates the ECU with other improvements:</p> <ul style="list-style-type: none">• WiTech turbo test revision.• ScanTool may report a code as stored, even though the fault has been cleared by completing a significant number of drive cycles without a repeat occurrence.• Active codes not always displayed correctly.• Engine derate with IOD removed. This will help prevent turbo damage due to oil thickening in cold climate start up on new vehicles in transit.• Enhancement to reduce shift clunk at stop.• Other drivability enhancements.• EGR Valve cleaning and monitoring enhancements to help reduce occurrences of P049D.

CATEGORY 19 STEERING

<u>TSB #</u>	<u>MODELS</u>	<u>SUBJECT/DESCRIPTION</u>
19-002-12 7/12/12	'03-'04 (DR) '05-'09 (DH) '06-'09 (D1) '07-'09 (DC) '10-'12 (D2/DJ/DD)	<p><i>The customer may experience steering wheel vibration typically while driving above 50 mph.</i></p> <p>Vehicles equipped with a solid front axle (4x4 or cab and chassis trucks) can be susceptible to steering shimmy. Often this condition is due to modifications to the vehicle that may involve aftermarket equipment that may not be compatible with the vehicle architecture or is not intended for on-road use. For original equipment, this condition can be corrected with routine inspection for properly maintained wheels and tires and replacement of damaged or worn components.</p>

Troubleshooting of the problem begins with the verification of warranty coverage and discussion with the customer. The technician is directed to test drive the vehicle to confirm the complaint

Next, a long series of inspections, questions, verifications and corrections are presented. The following gives you an example of how the troubleshooting is done:

Is the vehicle equipped with aftermarket components or other modifications (e.g. lift kits, wheels, suspension components or tires) that can affect the performance of or wear upon steering components? If the answer is "yes," the dealer is to notify the owner and document in the repair order that limited warranties do not cover conditions or damage caused by the use of aftermarket components, improper maintenance, or impact damage can cause steering shimmy or otherwise accelerate the wear of steering components that cause steering shimmy. The dealership can inspect steering components that were supplied by the manufacturer for defects in material, workmanship and factory preparation and determine if necessary repairs are covered under the terms of the warranties applicable to the vehicle. Clearly, aftermarket items may affect who pays for further inspection.

- Inspect the vehicle steering components for any damage.
- Are the tires on the vehicle properly inflated to the correct pressure?
- Do the tires exhibit a condition of excessive wear, cupping or damage?
- Verify proper wheel and tire balance.
- Inspect the steering damper.
- Does the track bar show signs of excessive wear or damage?
- Do the tie rods show signs of excessive wear or damage?
- Does the drag link show signs of excessive wear or damage?
- Verify vehicle wheel alignment is within specification and adjust accordingly.
- Do the ball joints show signs of excessive wear or damage?

Editor's Comments – Death Wobble

If you spend a day answering the tech line at Geno's Garage, you would be surprised at the number of phone calls asking about the "Death Wobble."

More often than not, the customer wants a one-size-fits-all answer to the problem. It is not that easy, and the Geno's staff suggests that they save money by crawling under the truck to diagnose the problem. So, it is refreshing to see that Dodge has helped us tackle the problem with a step-by-step repair procedure.

The TDR has also covered the death wobble problem and in Issue 74, pages 12-23, we presented "Steering Woes." If you are having death wobble problems, this article is well worth your reread.

Finally, there is a part not mentioned in the Dodge TSB that can be added to your truck to help stabilize the front end. My guess as to why Dodge didn't mention a steering box stabilizer is that it is an aftermarket item not offered through the Mopar parts system.

CATEGORY 21**TRANSMISSION AND TRANSFER CASE**

<u>TSB #</u>	<u>MODELS</u>	<u>SUBJECT/DESCRIPTION</u>
21-011-11 11/4/11	'11 (DD/DP)	<i>Difficulty climbing steep grades at maximum gross combined weight rating in third and fourth gear.</i> This bulletin applies to Cab and Chassis vehicles equipped with a six-speed Aisin automatic transmission. Customers may notice they have difficulty climbing steep grades at maximum gross combined weight rating while the vehicle is in third and fourth gear. This usually happens while towing a trailer. This could also be described as a lug down feeling in third and fourth gear. A new feature has been added to the TCM logic that allows new downshift points for the 4-3 and 3-2 downshifts. These new shift points keep the engine at or near peak horsepower to avoid this performance issue.
23-006-10 3/10/10	'10 (D2/DJ)	This bulletin involves flash reprogramming the transmission control module (TCM) with new software.

CATEGORY 23**BODY**

<u>TSB #</u>	<u>MODELS</u>	<u>SUBJECT/DESCRIPTION</u>
23-003-12 2/07/12	All Chrysler vehicles	<i>Hood creaking and squeaking sound.</i> This bulletin applies to D2/DJ vehicles built before January 29, 2010. The customer may experience a creaking and/or squeaking sound from the hood area when turning the vehicle and/or going over rough terrain This repair involves adding anti-squeak tape to the hood.
23-019-12 6/19/12	'12 (DJ/DD/D2/DP)	<i>Light to moderate paint surface imperfections on factory applied paint finish.</i> This "information only" bulletin applies to vehicles with isolated light to moderate paint surface imperfections (scratches, bird dropping stains, chemical etching, etc.) on factory applied paint. The bulletin outlines a list of Meguiar's products that can be used to clean the paint. Service personnel are reminded to always begin with the least aggressive method to remove a paint condition. Work one section at a time. Always work on a cool paint surface free of bonded surface contaminants. Should above surface defects be present; prepare the surface with Meguiar's Detailing Clay. <i>Editor's Comments – Paint Detailing</i> <i>When it comes to detailing a truck or car, nothing replaces good lighting, a sharp eye and lots of elbow-grease.</i> <i>Again, the TDR and its writers have "been there, done that," and the most recent article on detailing your truck is found in Issue 68, pages 58-65.</i>
		<i>Shaking motion in left rearview tow mirror assembly.</i> This bulletin applies to vehicles built before January 10, 2012. This bulletin involves inspecting and, if necessary, replacing the left rearview tow mirror assembly.

CATEGORY 25**EMISSIONS CONTROL**

<u>TSB #</u>	<u>MODELS</u>	<u>SUBJECT/DESCRIPTION</u>
25-002-11 12/6/11	'10-'12 (DJ/D2)	<p><i>On board diagnosis (OBD) monitor readiness.</i></p> <p>Vehicles that fail to pass a state mandated emissions inspection may have certain OBD readiness monitors that have not completely run. Anytime an ECM/PCM has been replaced or flashed, the OBD readiness monitors may need to run again to complete the monitoring process. This bulletin describes the necessary steps required to run each monitor.</p> <p>Customers may be required to drive the vehicle for an extended period of time in a variety of driving styles to allow all of the OBD monitors to run.</p>
25-003-11 12/6/11	'11-'12 (DD/DP)	<p><i>On board diagnosis (OBD) monitor readiness.</i></p> <p>Vehicles that fail to pass a state mandated emissions inspection may have certain OBD readiness monitors that have not completely run. Anytime an ECM/PCM has been replaced or flashed, the OBD readiness monitors may need to run again to complete the monitoring process. This bulletin describes the necessary steps required to run each monitor.</p> <p>Customers may be required to drive the vehicle for an extended period of time in a variety of driving styles to allow all of the OBD monitors to run.</p>
25-001-12 5/3/12	'10-'12 (DJ/D2) '11-'12 (DD/DP)	<p><i>Diagnostic trouble code (DTC) P0471 set in temperatures below freezing.</i></p> <p>This bulletin involves installing an insulated exhaust manifold pressure (EMP) sensor tube and insulation over the EMP sensor along with a new EMP sensor.</p> <p>During the normal combustion process, condensation can form in the EMP sensor tube. Rarely, this condensation may contact the EMP sensor pressure sensing element. If the vehicle is operating in temperatures below freezing, the condensation may freeze. The expanding moisture as it freezes could cause the pressure sensing element to crack causing damage to the EMP sensor and setting DTC P0471 will illuminate the MIL immediately after the fault becomes active.</p>
25-003-12 8/02/12	'11-'12 (DD/DP)	<p><i>Diesel exhaust fluid.</i></p> <p>This bulletin provides information regarding the diesel exhaust fluid (DEF) vehicle delivery fill guidelines. The bulletin supersedes 25-001-10 dated 9/1/10. The tank is pre-filled with approximately three gallons of DEF from the manufacturing assembly plant. This factory fill should be adequate to perform the vehicle's Pre-Delivery Inspection and other in-dealership operations.</p>

2012 RECALL NOTICES

◀ Return to [Table of Contents](#)

OUTER DASH SILENCER PAD AND HEAT SHIELD SAFETY RECALL (737)

The outer dash silencer pad, on the below listed vehicles, may contact the exhaust pipe. Under certain operating conditions, the exhaust pipe may become not enough to over heat or ignite the silencer pad. To correct this condition, part of the silencer pad must be removed and a heat shield must be added to the exhaust pipe.

Models: 1997 model year Dodge Ram (BR) trucks equipped with a 5.9L diesel engine ('D' in the 8th VIN Position) built at the:

- Saltillo Assembly Plant ('G' in the 11th VIN Position) from March 7, 1997 through May 15, 1997
- St. Louis North Assembly Plant ('J' in the 11th VIN Position) from March 15, 1997 through May 16, 1997
- Lago Alberto Assembly Plant ('M' in the 11th VIN Position) from March 18, 1997 through May 15, 1997

The service/repair procedure involves removal of a portion of the silencer pad and the installation of heat resistant foil tape to the remainder of the silencer pad and the installation of a heat shield onto the exhaust pipe.

IGNITION SWITCH WIRING RECALL (875)

The ignition switch and/or steering column wiring may overheat when the blower motor is operated at high speed for an extended period of time. This can cause stalling, loss of blower motor or power window operation, ABS or airbag lamp illumination or a steering column/instrument panel fire.

The vehicles involved in the recall have a vehicle identification number as follows:

- Warren ("S" in the 11th VIN position) through April 4, 1996;
- St. Louis ("J" in the 11th VIN position) through March 23, 1996;
- Lago Alberto ("M" in the 11th VIN position) through April 14, 1996;
- Saltillo ("G" in the 11th VIN position) through April 14, 1996.

The repair involves installing a blower motor relay and overlay harness to remove the blower motor circuit from the ignition switch. In addition, the ignition switch and electrical connector must be inspected for damage and replaced if necessary.

Note to TDR subscribers: the primary parts package for this repair does not include a replacement ignition switch assembly, but rather provides a blower motor relay and overlay harness; if necessary, an ignition switch wiring pigtail; clips, screws, washers, etc., to install the blower motor relay.

During the repair the ignition switch and associated connectors are to be inspected. The technician is instructed to look for indications of melting or deformation, specifically at terminals four and five. Very few vehicles are expected to require ignition switch replacement.

Editor's note: The title of the recall, "Ignition Switch Recall 875" leads one to conclude that the recall is to replace the ignition switch assembly. As summarized from the dealer service instructions, the recall has very little to do with the ignition switch, but rather is focused on adding a relay to the blower motor circuit. The moral of the story – don't jump to conclusions based on the title of a memo and be sure additional trailer light wiring and accessories that are added to your vehicle are on a separate relay-switched circuit.

FUEL TRANSFER PUMP RECALL (878)

The fuel transfer (lift) pump on about 12,000 24-valve vehicles may be susceptible to premature internal armature shaft bushing wear. Failure of the shaft bushing typically causes a no-start condition. To correct the problem, the supplier of the fuel transfer pump (Federal Mogul) has returned to the original sintered iron bushing design.

The suspect vehicles have a Cummins engine serial number sequence that falls between 56662576 and 56671920. These engines were installed at the DaimlerChrysler assembly plant in St. Louis from 12/3/99 to 1/18/00; Lago Alberto from 12/2/99 to 2/1/00; Saltillo from 12/2/99 to 2/1/00.

The replacement involves removal of the starter motor to gain access to the electronic transfer pump. Remove and install a replacement pump. Reinstall the starter and check for leaks and proper operation. The flat rate time schedule for replacement is approximately one hour.

THROTTLE CONTROL CABLE AND THROTTLE LINKAGE REPLACEMENT SAFETY RECALL (970)

DaimlerChrysler Corporation has determined that a defect, which relates to motor vehicle safety, exists in some 1994 through 1996 model year Dodge Trucks equipped with a Cummins Turbo Diesel engine (identified by a "C" in the eighth position of the VIN).

The throttle control cable on your Ram truck may fray and eventually break. A frayed throttle control cable may not allow the throttle to return to the idle position.

In addition, the throttle control linkage joints may corrode and cause the throttle to bind or stick.

Either of the above conditions could increase the truck's stopping distance and cause an accident without warning.

DaimlerChrysler will repair your truck free of charge (parts and labor). To do this, your dealer will replace your truck's throttle control cable and throttle linkage. The work will take about 1.0 hour to complete. The service/repair procedure involves removal of the throttle control cable, throttle linkage rod ends and linkage ball studs as all of these parts are replaced. Detailed removal and reinstallation instructions are provided to the dealership (reference Safety Recall 970).

If you have already experienced the problem described above and have paid to have it repaired, you may send your original receipts and/or other adequate proof of payment to the following address for reimbursement: DaimlerChrysler Customer Assistance Center, PO Box 1040, St. Charles, MO 63302-1040, Attention: Recall Center.

**UPPER CONTROL ARM FASTENERS
(Recall 955)**

2001 BR/BE Ram Truck Quad Cab manufactured in July 2000. The upper control arms attached with cadmium coated nuts can cause the bolts to stretch due to the application of a higher than specified clamp load. Breakage of the upper control arm fasteners could cause the axle to rotate forward under braking conditions. This rotation could twist the steering linkage and possibly separate the brake lines, increasing the risk of a crash. Dealers will replace the upper control arm bolts and nuts.

**REAR AXLE SPACER PLATE
(Recall 966)**

2001 (BR/BE) Dodge Ram Truck Quad Cab equipped with a camper package and overload springs manufactured in July 2000.

The rear axle spacer plate could lead to deformation of the upper spring plate during assembly of the axle to the vehicle resulting a soft joint. The soft joint could cause the rear axle U-bolts to lose clamp load, resulting in displacement of the rear axle and a loss of vehicle control. This could increase the risk of a crash. Dealers will remove the spacer plates and the spring plates will be replaced.

**THROTTLE CABLE
(Recall 970)**

1994-1996 (BR/BE) Dodge Ram Truck with diesel engine manufactured from July 1993 to July 1996.

On certain pickup trucks, the throttle cable could unravel (fray) or break, resulting in a loss of throttle control. A throttle that does not return to idle could result in unexpected acceleration, increasing the risk of a crash. Dealers will inspect and replace the throttle cable and upper bell crank lever.

**BRAKE HOSE/ABS SENSOR WIRE
ASSEMBLY CLEARANCE
(Recall 971)**

2000 (BR/BE) Dodge Ram Truck with ABS manufactured from July 1999 To September 1999.

Some vehicles may have inadequate clearance between the front tire/wheel and the brake hose/ABS sensor wire assembly. During full lock turns, it is possible for the tire or wheel to contact the brake hose/ABS sensor wire assembly.

This could ultimately result in wire damage and/or a hole in the brake line, affecting brake effectiveness, increasing the risk of a crash. Dealers will replace the front brake hose assemblies, and the ABS sensor wire will be inspected and replaced if necessary.

**CLOCKSPRING
(Recall 982)**

2001 (BR/BE) Dodge Ram Truck manufactured from May 2000 To October 2000.

Sound deadener material internal to the clockspring could become detached from the clockspring cover and housing. When this occurs, the material could interfere with the clockspring ribbon and cause an open circuit. The driver air bag system will become disabled and the air bag warning lamp will illuminate on the instrument panel. Dealers will replace the clockspring assembly.

**CUSTOMER SATISFACTION NOTIFICATION NO. C44
TRANSMISSION COOLER LINE**

Date: February 2004
Models: '03-'04 (DR)

This notification applies only to trucks equipped with a 5.9 liter Cummins diesel engine (sales code ETC or ETH) and an automatic transmission (sales code DG8 or DGP) built through November 24, 2003. The transmission cooler line on about 97,000 of the above vehicles can transmit high pressure pulses when the vehicle is operated at heavy loads. These pulses may cause the engine-mounted transmission cooler to crack and leak fluid which could result in significant transmission damage.

Repair: The transmission cooler line must be replaced on all involved vehicles. In addition, the engine-mounted transmission cooler must be inspected and replaced if necessary.

**CUSTOMER SATISFACTION NOTIFICATION NO. C42
POWERTRAIN CONTROL MODULE CONNECTORS**

Date: February 2004
Models: '03 (DR)

This notification applies only to trucks equipped with a 5.9 liter Cummins diesel engine (sales code ETC or ETH) and an automatic transmission (sales code DGP or DG8) built through July 9, 2003. The Powertrain Control Module (PCM) electrical connectors on about 70,000 of the above trucks may allow water to enter into the connectors. Water and the resulting corrosion in a PCM connector can cause the speed control and/or transmission overdrive function to become inoperative.

Repair: The three electrical connectors on the PCM must be removed and inspected for corrosion. If no corrosion is found, the connectors must be sealed by installing rubber O-rings onto the harness connectors.

If corrosion is found in the connector, the transmission wiring harness and PCM must be replaced.

**CUSTOMER SATISFACTION NOTIFICATION E10
FRONT SUSPENSION COIL SPRINGS**

Date: July 2005

Models: '05 (DH) Dodge Ram 3500 4x2 Pickup Truck

This notification applies only to the above vehicles built through May 27, 2005. Incorrect front coil springs may have been installed on about 8,100 of the above trucks' front suspension. This may cause the front suspension to bottom out prematurely, which can reduce ride quality.

Repair: Both front suspension coil springs must be replaced.

**SAFETY RECALL E17
OUT-OF-PARK ALARM SYSTEM**

Date: March 2006

Models: '03 – '04 (DR)
'05 (DH)

This recall applies only to the vehicles equipped with a 5.9L diesel engine (6 or C in the eighth VIN Position) and an automatic transmission (sales code DGP or DG8). In certain circumstances when a driver has not placed the shifter lever fully into the "Park" position and leaves the engine running, the vehicle may unexpectedly move rearward after seeming to be stable. Unintended rearward movement of a vehicle could injure those in and/or near the vehicle.

Repair: An Out-of-Park alarm system must be installed on the vehicle. The alarm system will beep the horn and flash the headlamps and shift indicator if a driver tries to exit a running vehicle without fully placing the shifter into the "Park" position.

**SAFETY RECALL F05
ANTILOCK BRAKE SYSTEM CONTROL MODULE**

Date: July 2006

Models: '06 (D1) Dodge Ram Pickup (3500 Series)
'06 (DH) Dodge Ram Pickup (1500 Mega Cab
and 2500 Series)

This recall applies only to the above vehicles equipped with a four-wheel Antilock Brake System (sales code BGK or BRT) built from September 12, 2005 through December 11, 2005. The Antilock Brake System (ABS) control module on about 37,900 of the above vehicles may cause the rear brakes to lock up during certain braking conditions. This could result in a loss of vehicle control and cause a crash without warning.

Repair: The ABS control module must be replaced and initialized with the StarSCAN tool.

**CUSTOMER SATISFACTION NOTIFICATION F19
ROLL-OVER VALVE VENT HOSES**

Date: June 2006

Models: '06 (DH) Dodge Ram 2500 Pickup and Cab-Chassis
'06 (D1) Dodge Ram 3500 Pickup and Cab-Chassis

This notification applies only to the above vehicles equipped with a 5.9L diesel engine (C in the eighth VIN position) built through February 1, 2006. The roll-over valves on about 69,300 of the vehicles may allow water to enter into the fuel tank. Excessive water in the fuel can damage the injection pump and/or injectors if the engine is off for an extended period of time.

Repair: A vent hose must be installed at each tank roll-over valve (ROV). The fuel system must be inspected for excessive water content. If excessive water is found, the water must be removed and the fuel filter must be replaced.

**EMISSIONS RECALL G30
REPLACE OXYGEN SENSOR MODULE
AND REPROGRAM ECM**

Date: October 2007

Models: '07–'08 (DH/D1) Dodge Ram 2500/3500
Pickup Truck

This notification applies only to the above vehicles equipped with a 6.7-liter diesel engine built through August 20, 2007. The on-board diagnostic (OBD) system on about 74,000 of the above vehicles may not detect a failed oxygen sensor or illuminate the malfunction indicator light (MIL) as required. In addition, the OBD system may cause these trucks to fail an inspection maintenance test and may not store mileage as required for certain transmission faults.

Repair: The oxygen sensor module must be replaced and the engine control module (ECM) must be reprogrammed (flashed). The new software will also improve vehicle drivability and reduce the potential for exhaust soot accumulation in the vehicle's particulate filter. The recalibration of the ECM updates and supersedes TSB 18-033-07 Revision B, dated 6/28/07 (see page 63 for details).

**EMISSIONS RECALL H31
VECI LABEL**

Date: October 2008

Models: '08 (D1) Dodge Ram 3500
Truck Cab and Chassis

An incorrect Vehicle Emission Control Information (VECI) label was inadvertently installed on about 60 of the above vehicles. The original VECI label does not include the required information for vehicles built without a pickup box.

Repair: A new VECI label must be installed over the vehicle's original VECI label.

**SAFETY RECALL H34
DASH SILENCER PAD**

Date: January 2009
Models: '07 – '08 (DH, D1, DC, DM)

The dash silencer pad on about 110,000 vehicles, built with a Cummins 6.7-liter diesel engine through 11/5/07, may sag and contact the exhaust gas recirculation (EGR) cooler. This may cause the dash silencer to locally overheat and cause an underhood fire without warning.

Repair: All vehicles must have a dash silencer pad support bracket installed.

**SAFETY RECALL H36
STEERING DRAG LINK INNER JOINT
AND DAMPER BRACKET**

Date: May 2009
Models: '08 – '09 (DH/D1) 2500/3500 series or
1500 Mega Cab (4x4 only)
'08 – '09 (DC) 3500 series Cab Chassis

This recall applies only to the above vehicles built from February 19, 2008 through October 30, 2008.

The steering drag link inner joint on about 32,700 of the above vehicles may fracture under certain driving conditions. This could result in a loss of steering control and cause a crash without warning.

Also the steering damper bracket at the tie rod tube may loosen. This could allow the bracket to slide on the tube and may cause increased vehicle turning radius.

Repair: The drag link inner joint must be replaced and the steering damper bracket must be inspected and replaced, if required.

**SAFETY RECALL H46
MOPAR STEERING LINKAGE**

Date: May 2009
Models: '03 – '04 (DR) 2500/3500 series 4x4
'05 (DH) 2500/3500 series 4x4
'06 – '09 (DH) 2500/3500 series or 1500 Mega
Cab 4x4
'06 – '09 (D1) 3500 series 4x4
'07 – '09 (DC) 3500 series Cab Chassis

This recall only applies to vehicles that had certain Mopar service parts steering components installed.

During a prior service appointment, a Mopar service parts steering linkage was installed on about 13,900 of the above vehicles. The drag link inner joint may fracture under certain driving conditions. This could result in a loss of steering control and cause a crash without warning.

Also, the steering damper bracket at the tie rod tube may loosen. This could allow the bracket to slide on the tube and may cause increased vehicle turning radius.

Repair: The steering linkage must be inspected and some steering linkage components may need to be replaced.

**CALIFORNIA EMISSIONS RECALL K01
REPROGRAM ECM—OBD READINESS**

Date: May 2010
Models: '03 (DR) Dodge Ram 2500/3500 Pickup Truck
'06-'07 (DH/D1) Dodge Ram 2500/3500 Pickup
Truck
'07 (DC) Dodge Ram 3500 Cab Chassis

This recall applies only to the above vehicles equipped with a 5.9-liter diesel engine (sales codes ETC and ETH) and a California emission control system (sales code NAE). And to above vehicles equipped with a 6.7-liter diesel engine (sales code ETJ) and a California emission control system (sales code NAE) built through January 5, 2007.

The Engine Control Module (ECM) on the above vehicles may fail to accurately report diagnostic system information with some generic scan tools. This may cause the vehicle to be rejected or fail an Inspection/Maintenance Test (also known as a Smog Check).

Repair: The Engine control Module (ECM) must be reprogrammed (flashed).

**EMISSIONS RECALL J35
REPROGRAM ECM—REGENERATION STRATEGY**

Date: April 2010
Models: '07.5-'09 (DH/D1) Dodge Ram 2500/3500 Pickup
Truck

This recall applies only to the above vehicles equipped with a 6.7-liter diesel engine (sale code ETJ). The Engine Control Module (ECM) software program on the above vehicles may cause illumination of the Malfunction Indicator Lamp (MIL) when no problem exists or under certain conditions allow heavy sooting of the turbocharger, exhaust gas recirculation valve and diesel particulate filter. Heavy sooting could damage emissions components and result in increased emissions.

Repair: The Engine Control Module must be reprogrammed (flashed). The bulletin describes the service procedure that the dealership technician is to follow. Using the dealership's scan tools, the time allowance for the reprogramming operation is less than one hour. As a part of the recall and ECM update the technician has to verify that the previous emissions recall, recall G30, October 2007, has been performed. The G30 recall contains software that must be installed to prevent damage to the ECM. There are no parts involved in the J35 recall notice.

**SAFETY RECALL K08
WIRELESS IGNITION NODE RECEIVER**

Date: August 2010
Models: '10 (DJ) Ram Truck (2500 Series)
'10 (D2) Ram Truck (3500 Series)

This recall applies only to the above vehicles built at Saltillo Assembly Plant ("G" in the 11th VIN position) equipped with an automatic transmission from January 6, 2010 through February 16, 2010. This recall also affected other Chrysler vehicles.

The Wireless Ignition Node (WIN) receiver on about 8,900 of the above vehicles may experience a condition where the Frequency Operated Button Integrated Key (FOBIK) may be removed prior to placing the automatic transmission gear shift lever in the "PARK" position. This could result in unintended vehicle movement and cause a crash without warning.

To correct this condition, the Wireless Ignition Node receiver must be inspected and replaced if necessary. The new WIN must be programmed and all FOBIK transponders must be programmed so they are able to interface with the new WIN receiver.

**CUSTOMER SATISFACTION NOTIFICATION K17
REPROGRAM HVAC CONTROL HEAD AND INSPECT/
REPLACE ACTUATORS**

Date: September 29, 2010
Models: '10 (DJ) Ram Truck (2500 series)
'10 (D2) Ram Truck (3500 series)

This recall applies only to the above vehicles built through May 22, 2010

The HVAC mode door actuator gears on about 52,000 of the above vehicles may break and result in the inability to fully control the HVAC functions.

To correct this condition, all involved vehicles must have updated HVAC control head software installed and the mode door actuators must be tested and replaced as required.

**SAFETY RECALL K28
LEFT TIE ROD END**

Date: February 2011
Models: '08-'10 (DM) Ram Truck (4500/5500 series cab chassis)
'11 (DP) Ram Truck (4500/5500 series cab chassis)

This recall applies only to the above vehicles built through September 02, 2010.

The left outer tie rod end on about 15,500 of the above vehicles may fracture due to a misalignment condition. Under certain driving conditions, this may lead to a weakening and eventual fracture of the left outer tie rod ball stud. A fractured tie rod end could cause a loss of directional stability and a crash without warning.

The left outer tie rod end must be replaced, toe-in must be set, and the tie rod ends must be aligned.

**CUSTOMER SATISFACTION NOTIFICATION L14
REPROGRAM HVAC CONTROL HEAD**

Date: April 12, 2011
Models: '10 (D2) Ram Truck (2500 series)
'10 (DJ) Ram Truck (3500 series)

This notification applies only to the above vehicles built with Manual Temperature Control (MTC) from March 18, 2010, through June 24, 2010.

The Heating, Ventilation, and Air Conditioning (HVAC) control head software on about 10,330 of the above vehicles may cause the mode door actuator gears to make noise and/or break. This could cause the inability to fully control the HVAC functions.

To correct this condition, the HVAC control head must be reprogrammed with new software.

**SAFETY RECALL K33
POWER STEERING RESERVOIR CAP**

Date: February 1, 2011
Models: '10-'11 (DC/DM/DJ/D2/DD/DP) Ram Truck

This recall applies only to the above vehicles equipped with a Cummins engine built at the Saltillo Assembly Plant ("G" in the 11th VIN Position) through October 05, 2010.

The power steering reservoir cap on about 11,300 of the above vehicles may cause excessive vent pressure levels in the power steering/hydraulic brake booster system. This may cause the vehicle to have brake lights that remain illuminated for an extended period of time after the brake pedal has been released. Brake lights that are slow to turn off could increase the risk of a crash.

To correct this condition, the power steering reservoir cap must be replaced.

EMISSIONS RECALL K34 REPROGRAM ECM – EGR DIAGNOSTIC

Date: February 8, 2011

Models: '10 (DJ/D2) Ram Truck (2500/3500 series pickup)

This recall applies only to the above vehicles equipped with a Cummins engine built from October 1, 2009, through June 24, 2010.

The Engine Control Module (ECM) on about 1193 of the above vehicles may have been built with a software error that prevents the EGR cooler bypass valve diagnostic from running after detecting a pending fault, disabling deNOx without illuminating the MIL. This may cause the vehicle's exhaust emissions to exceed the allowable limit for oxides of nitrogen.

To correct this condition, the Engine Control Module (ECM) must be reprogrammed (flashed).

CUSTOMER SATISFACTION NOTIFICATION L03 DOOR LATCHES

Date: March 2011

Models: '11 (D2) Ram Truck (3500 Series) Pick up

'11 (DD) Ram Truck (3500 Series) Cab Chassis

'11 (DJ) Ram Truck (2500 Series) Pick up

'11 (DP) Ram Truck (4500/5500 Series) Cab Chassis

This notification applies only to the above vehicles equipped with power door locks (sales code JPB) built from July 01, 2010, through November 23, 2010.

The right front door latch, right rear door latch and/or swing gate latch on about 35,000 of the above vehicles may develop a ratcheting sound while using the power door locks.

The right front door latch and right rear door latch must be inspected and replaced if necessary.

SAFETY RECALL L16 LEFT TIE ROD

Date: March 2012

Models/Production:

'08-'09 (DH) 2500 (4x4)

'08-'09 (D1) 3500 (4x4)

'10-'11 (DJ) 2500 (4x4)

'10-'11 (D2) 3500 (4x4)

'08-'10 (DC) 3500 Cab Chassis

'11 (DD) 3500 Cab Chassis

This recall applies only to the above vehicles built at the Saltillo Assembly Plant ("G" in the 11th VIN Position) from February 14, 2008, through March 28, 2011.

Models/Service Parts:

'03-'04 (DR) 2500/3500 (4x4)

'06-'08 (D1) 3500 (4x4)

'07-'08 (DC) 3500 Cab Chassis

'05-'08 (DH) 2500 (4x4)

'05 (DH) 3500 (4x4)

This recall applies only to the above vehicles that were built between July 12, 2002, and February 13, 2011, and had the steering linkage replaced with Mopar service parts after February 14, 2008.

Subject: The left tie rod ball stud on about 208,000 of the above vehicles may fracture under certain driving conditions. This could cause a loss of directional control and/or a crash without warning.

The same vehicles may also have a loose front track bar bolt. This could cause a rattle or banging noise under certain driving conditions.

Repair: The vehicle must be inspected for the type of steering linkage the vehicle is equipped with and those found with a certain linkage configuration must have the right and left tie rod angles measured. If the tie rod angles are not within specification, the left tie rod must be replaced.

Note: special Tool 10326 was released to dealers in November of 2010. Service Bulletin 19-001-11 was also issued to alert dealers to the new service tool and procedure for setting toe on the affected, and all subsequent, vehicles.

Conclusion

Wow, what a listing of information! Thanks, again, to the TDR members that forward information to us. Also, thanks to those at Chrysler and Cummins that provided their insight. This text concludes the TSB listing(s) for '03-'09 Third Generation trucks.

Is the grass greener on the other side? We hope the TSB and Recall information will help you in your purchase/ownership of the Dodge Cummins Turbo Diesel truck. We choose to think that answers and solutions are much better than wonderment. Happy Motoring!

TECHNICAL SERVICE BULLETINS ISSUED DURING 2013

CATEGORY 7 COOLING

<u>TSB#</u>	<u>MODEL</u>	<u>SUBJECT/DESCRIPTION</u>
07-001-12 2/14/12	'11 DJ/D2	<p><i>Transmission cooler Hose Weepage.</i></p> <p>Some of the listed vehicles have been built with a transmission cooler hose that may experience fluid weepage. This bulletin involves inspecting the upper transmission cooler hose for a specific date code and time stamp. If found within the suspect range, the transmission cooler hose must be replaced. The vehicle range is from 9/20/10 to 1/17/11.</p> <p>Editor's Comment: This is a TSB from last year (2012) that we missed including in our Issue 78 summary.</p>

CATEGORY 8 ELECTRICAL

Editor's Comments: Section 8/Electrical – Radios and Media Center Units

Wow! As I mentioned, were it not for reprogramming radio units, our list of TSBs for 2013 would be very small. As you look through the following you'll see what I mean.

And, from conversations with suppliers to Chrysler, I know it is expensive to have a TSB issued due to a flash or electronic update being necessary. So, who makes the Chrysler radio/media center unit? Makes you wonder...

<u>TSB#</u>	<u>MODEL</u>	<u>SUBJECT/DESCRIPTION</u>
08-065-12 12/20/12	'12 DJ/D2	<p><i>RHR Navigation Map Enhancements</i></p> <p>This bulletin applies to vehicles built with an Uconnect 730N Navigation Radio (sales code RHR). This bulletin involves updating the RHR radios navigation map database software.</p>
08-010-13 2/28/13	'10-'11 DJ/D2 '11 DD/DP	<p><i>Fluid Leak from Washer Reservoir</i></p> <p>A customer may have a condition where fluid is leaking from the washer reservoir. On further inspection the technician may find cracks in the reservoir by the washer pump pocket. This bulletin involves inspecting and/or replacing the washer reservoir. This bulletin applies to vehicles built before March 30, 2012, equipped with a diesel engine.</p>
08-021-13 3/29/13	'12 DJ/D2/DD/DP	<p><i>Flash: Hands Free Module Customer Satisfaction Enhancements</i></p> <p>This bulletin applies to vehicles built up to January 1, 2012, with media center sales code RSP, RSQ. This 12 page bulletin gives the instructions for performing a USB service flash of the Hands Free Module (HFM).</p>
08-042-13 7/20/13	'13 DD/DP	<p><i>Flash: Remote Start Will Not Shut Vehicle Off</i></p> <p>This bulletin applies to vehicles built on or after March 02, 2013, and on or before April 19, 2013, equipped with Hard Wired Remote Start (sales code XBV). The customer may note the remote start works properly when starting the vehicle. The remote may not be able to turn off the vehicle. This bulletin involves reprogramming the Radio Frequency Hub (RF-Hub) with updated software.</p>
08-049-13 Rev C 8/14/13	'13 DJ/D2/DD/DP	<p><i>RA3 And RA4 Radio Enhancements</i></p> <p>A customer may experience problems with the Uconnect 8.4 radio, sales code RA3 or RA4. This bulletin applies to vehicles built before June 15, 2013. This bulletin involves upgrading the software on the RA3 and RA4 Radio.</p>
08-057-13 7/30/13	'13 DD/DP	<p><i>Flash: Power Take Off (PTO) Enhancements</i></p> <p>A customer may experience that the PTO will shut off after 30 minutes of operation. The PTO will start working again after the ignition is cycled. This bulletin involves updating the Vehicle System Interface Module (VSIM) software. This bulletin applies to vehicles built on or after January 16, 2013, on or before May 10, 2013, equipped with Electronic Monitoring Module (sales code XXS) and Power Take Off Prep (sales code LBN).</p>

CATEGORY 8**ELECTRICAL**

<u>TSB#</u>	<u>MODEL</u>	<u>SUBJECT/DESCRIPTION</u>
08-058-13 7/31/13	'13 DJ/D2/DD/DP	<p><i>After Radio Replacement, Cannot Register Uconnect Access or Critical VIN Error Message Is Displayed</i></p> <p>This service bulletin applies to vehicles equipped with a Uconnect 8.4 radio (sales code RA3or RA4). After head unit replacement it is important to verify that a consistency check has occurred to ensure the Uconnect Access features are capable of connecting to the cloud. A consistency check occurs to register the replaced head unit's data with vehicle VIN into the databases associated with the Uconnect Access features. This check occurs over the cloud and under most conditions, the consistency check completes automatically and only verification of connectivity is required.</p>
08-060-13 8/8/13	'13 DD/DP	<p><i>Backup Camera Display Screen Is Blank</i></p> <p>This bulletin applies to vehicles built on or before May 10, 2013, equipped with ParkView Rear Back-up Camera (sales code XAC). A customer may experience that the screen for the back-up camera is blank when the truck is in reverse. This bulletin involves installing a jumper harness to correct the problem.</p>
08-061-13 8/9/13	'12 DJ/D2/DD/DP	<p><i>RBZ or RHB Radio Software Enhancements</i></p> <p>This bulletin applies to vehicles built on or before April 30, 2013, equipped with a sales code RBZ or RBH Media Center. The customer may experience one or more of the following.</p> <ul style="list-style-type: none"> • Digital photos loaded onto the hard drive intermittently get lost • CD/DVD will not play (RHB only) • Navigation accept screen will not clear (RHB only) • Navigation shows "acquiring signal" for an extended period of time (RHB only) • New navigation graphics (RHB only) • Sirius audio pop on power up • HFM audio pop on power up • Trip planner does not save a route after it was created (RHB only) • Route guidance does not activate after the vehicle shuts down (RHB only) • Longitude entry does not allow enough digits (RHB only) <p>If the customer experiences any of the above problems, an upgrade to the media center software is to be performed.</p>
08-066-13 8/21/13	'11-'12 DJ/D2	<p><i>RHR, RHW, or RHP Radio Software Enhancements</i></p> <p>This bulletin applies to vehicles equipped with Media Center 730N radio sales code RHW, RHR, or RHP. The customer may experience one or more of the following conditions.</p> <ul style="list-style-type: none"> • Lost channel presets, home addresses, address book entries and travel link favorites • Not able to change default country and state then route • Unable to load.jpeg files onto hard drive to display on touch screen • Incomplete Travel Link temperature displayed when the temperature is over 100°F • iPhone4 dial not possible after second call • Missing Travel Link buttons from SAT menu • Devices button disabled in VES menu • Unable to route to a recent route after a map update. • Remove Travel Link disclaimer popup • During active call and on hold, DIAL button should be displayed (not "TONE" button) • Point of Interest (POI) Search enhancements • When video in remote DVD player is stopped, devices button wrongly labeled as DVD • Access Travel Link immediately after radio no update when staying on TL screen • iPod, track selection enhancements. <p>This bulletin involves upgrading the software on the RHR, RHW, or RHP radio.</p>

CATEGORY 8**ELECTRICAL**

<u>TSB#</u>	<u>MODEL</u>	<u>SUBJECT/DESCRIPTION</u>
08-058-13 7/31/13	'13 DJ/D2/DD/DP	<p><i>After Radio Replacement, Cannot Register Uconnect Access or Critical VIN Error Message Is Displayed</i></p> <p>This service bulletin applies to vehicles equipped with a Uconnect 8.4 radio (sales code RA3or RA4). After head unit replacement it is important to verify that a consistency check has occurred to ensure the Uconnect Access features are capable of connecting to the cloud. A consistency check occurs to register the replaced head unit's data with vehicle VIN into the databases associated with the Uconnect Access features. This check occurs over the cloud and under most conditions, the consistency check completes automatically and only verification of connectivity is required.</p>
08-060-13 8/8/13	'13 DD/DP	<p><i>Backup Camera Display Screen Is Blank</i></p> <p>This bulletin applies to vehicles built on or before May 10, 2013, equipped with ParkView Rear Back-up Camera (sales code XAC). A customer may experience that the screen for the back-up camera is blank when the truck is in reverse. This bulletin involves installing a jumper harness to correct the problem.</p>
08-061-13 8/9/13	'12 DJ/D2/DD/DP	<p><i>RBZ or RHB Radio Software Enhancements</i></p> <p>This bulletin applies to vehicles built on or before April 30, 2013, equipped with a sales code RBZ or RBH Media Center. The customer may experience one or more of the following.</p> <ul style="list-style-type: none"> • Digital photos loaded onto the hard drive intermittently get lost • CD/DVD will not play (RHB only) • Navigation accept screen will not clear (RHB only) • Navigation shows "acquiring signal" for an extended period of time (RHB only) • New navigation graphics (RHB only) • Sirius audio pop on power up • HFM audio pop on power up • Trip planner does not save a route after it was created (RHB only) • Route guidance does not activate after the vehicle shuts down (RHB only) • Longitude entry does not allow enough digits (RHB only) <p>If the customer experiences any of the above problems, an upgrade to the media center software is to be performed.</p>
08-066-13 8/21/13	'11-'12 DJ/D2	<p><i>RHR, RHW, or RHP Radio Software Enhancements</i></p> <p>This bulletin applies to vehicles equipped with Media Center 730N radio sales code RHW, RHR, or RHP. The customer may experience one or more of the following conditions.</p> <ul style="list-style-type: none"> • Lost channel presets, home addresses, address book entries and travel link favorites • Not able to change default country and state then route • Unable to load.jpeg files onto hard drive to display on touch screen • Incomplete Travel Link temperature displayed when the temperature is over 100°F • iPhone4 dial not possible after second call • Missing Travel Link buttons from SAT menu • Devices button disabled in VES menu • Unable to route to a recent route after a map update. • Remove Travel Link disclaimer popup • During active call and on hold, DIAL button should be displayed (not "TONE" button) • Point of Interest (POI) Search enhancements • When video in remote DVD player is stopped, devices button wrongly labeled as DVD • Access Travel Link immediately after radio no update when staying on TL screen • iPod, track selection enhancements. <p>This bulletin involves upgrading the software on the RHR, RHW, or RHP radio.</p>

CATEGORY 18**VEHICLE PERFORMANCE**

<u>TSB#</u>	<u>MODEL</u>	<u>SUBJECT/DESCRIPTION</u>
18-001-13 1/5/13	'12 DJ/D2	<p><i>Flash: Diagnostic and System Improvements</i></p> <p>The following improvements/enhancements are available for the listed DTCs:</p> <ul style="list-style-type: none">• P049D – EGR control position exceeded learning limit• P0101 – Mass air flow sensor “A” circuit performance• P0191 – Fuel rail pressure sensor circuit performance• P2000 – NOx absorber efficiency below threshold (diagnostic improvements)• P2002 – Diesel particulate filter efficiency below threshold (for high altitude failures)• P2195 – O2 sensor 1/1 out of range high• P2196 – O2 sensor 1/1 out of range low• P2270 – O2 sensor 1/2 out of range high• P2271 – O2 sensor 1/2 out of range low• P241A – O2 sensor 1/1 and 1/2 oxygen concentration mismatch• P242F – Diesel particulate filter restriction – ash accumulation• P2453 – Diesel Particulate filter pressure sensor a circuit performance• P2609 – Intake air heater system performance <p>This bulletin involves selectively erasing and reprogramming the Engine Control Module (ECM) with new software.</p>
18-005-13 1/23/13	'10 DJ/D2	<p><i>Flash: Diagnostic and System Improvements</i></p> <p>The following improvements/enhancements are available for the listed DTCs:</p> <ul style="list-style-type: none">• P2000 – NOx absorber efficiency below threshold• P1451 – Diesel particulate filter system performance• P0101 – Mass air flow sensor “A” circuit performance• P046C – EGR position sensor performance• P049D – EGR control position exceeded learning limit• P051B – Crankcase pressure sensor circuit range/performance• P2002 – Diesel particulate filter efficiency below threshold• P2262 – Turbocharger boost pressure not detected – mechanical• P2609 – Intake air heater system performance <p>Improvements other than DTC robustness or enhancements:</p> <ul style="list-style-type: none">• O2 Sensor cleaning cycle• Correct Charge Air Cooler (CAC) out voltage reading in WiTech• Improve idle shutdown messages• Add ability to read Exhaust Manifold Pressure (EMP) sensor value in WiTech• Display correct Exhaust Gas Recirculation (EGR) position in WiTech• Make Grid Heater off time selectable in WiTec• Display correct alternator voltage in WiTech• Turn Low voltage Idle Up Off• Other drivability enhancements• MIL on with no DTC• Ability to read EGR valve gap on WiTech• Erroneous, brief brake lamp flash at key on <p>DTC U1601 set outside of the dealership with a no crank (towed in), no start condition caused by unauthorized (up-rate) software will not be covered under the terms of the warranty.</p> <p>Truck exhibiting any DTC related to Oxygen Sensor, Oxygen Sensor Module or communication to the Oxygen Sensor Module also require that service bulletin 25-004-12 (or later bulletin) be performed (if not previously performed).</p>

<u>TSB#</u>	<u>MODEL</u>	<u>SUBJECT/DESCRIPTION</u>
18-012-13 3/6/13	'12 DD/DP	<p><i>Flash: Diagnostic and System Enhancements</i></p> <p>Cab chassis trucks equipped with a 6.7-liter Cummins diesel have a number of software improvements available. This latest service bulletin(SB) will include:</p> <p>Improvements to prevent unnecessary Malfunction Indicator Lamp (MIL) illumination for:</p> <ul style="list-style-type: none">• P061A – ETC level 2 torque performance• P229F – Aftertreatment NOx sensor circuit performance – Bank 1 Sensor 2• P2453 – Diesel particulate filter pressure sensor a circuit performance• P2609 – Intake air heater system performance• P1123 – Power take off system monitor control error• U010E – Lost communication with diesel exhaust fluid control unit• P20EE – SCR NOx catalyst efficiency below threshold – Bank 1; for DTC's set at highway speed and/or high load drive cycles. <p>Enhanced diagnostics for:</p> <ul style="list-style-type: none">• Selective catalyst reduction (SCR) efficiency diagnostic improvements <p>Other updates:</p> <ul style="list-style-type: none">• Too frequent regeneration readiness improvement• Correct CAC out voltage in WiTech• Add ability to read EMO sensor value in WiTech• Enable EMP de-icing algorithm• Display correct crankcase pressure in WiTech• Display correct EGR position in WiTech• Improve idle shutdown messages – extra message removed• Display correct alternator voltage in WiTech• Idle shutdown message on EVIC• Turbo protection feature (not displayed if vehicle is in park or no vehicle speed). Limits RPM at cold ambient to prevent turbo damage• Scan tool display updates• Correct operation of remote PTO• System robustness improvements <p>This bulletin involves selectively erasing and reprogramming the Engine Control Module (ECM) with new software.</p>

<u>TSB#</u>	<u>MODEL</u>	<u>SUBJECT/DESCRIPTION</u>
18-013-13 3/14/13	'11 DD/DP	<p><i>Flash: Engine Systems and PTO Enhancements</i></p> <p>Cab Chassis trucks have a number of software improvements available. This latest Service Bulletin (SB) will include:</p> <p>Improvements to prevent unnecessary Malfunction Indicator Lamp (MIL) illumination for:</p> <ul style="list-style-type: none">• P0524 – Engine oil pressure sensor circuit low• P051B – Crankcase pressure sensor circuit range/performance• P20EE – SCR NOx catalyst efficiency below threshold – Bank 1• U010E – Lost communication with diesel exhaust fluid control unit• P2609 – Intake air heater system performance• P061A – ETC level 2 torque performance• P1123 – Power take off system monitor control error• P2579 – Turbocharger speed sensor circuit performance• P2453 – Diesel particulate filter pressure sensor a circuit performance• U059F – Invalid data received from NOx sensor “B” <p>Enhanced diagnostics for:</p> <ul style="list-style-type: none">• Variable geometry turbocharger• Fuel level sensor• Misfire without MIL illumination <p>Other Updates:</p> <ul style="list-style-type: none">• Too frequent regeneration readiness improvement• Correct CAC out voltage in WiTech• Add ability to read EMO sensor value in WiTech• Enable EMP deicing algorithm• Display correct crankcase pressure in WiTech• Display correct EGR position in WiTech• Display correct alternator voltage in WiTech• Improve idle shutdown messages – extra message removed• Low Diesel Exhaust Fluid (DEF) level EVIC messaging strategy changes• Oil change monitor – updated for easier reset (same basic procedure, easier to reset)• Scan tool display updates• Enable mobile PTO capability• Correct operation of remote PTO• Correct EVIC messaging related to DEF level reporting• System robustness improvements• DEF tank level reporting erroneously at high DEF tank level. When DEF tank is overfilled, the EVIC may display low fluid level (20-22%) <p>This bulletin involves selectively erasing and reprogramming the Engine control Module (ECM) with new software.</p>

CATEGORY 18**VEHICLE PERFORMANCE****TSB#****MODEL****SUBJECT/DESCRIPTION**

18-018-13 '13 DJ/D2
Rev B
8/15/13

Flash: Diagnostic and System Improvements

Several software improvements are available for vehicles equipped with the 6.7-liter diesel engine:

Prevent or reduce unnecessary Malfunction Indicator Lamp (MIL) illumination for the following transmission faults. These faults are currently tripped as a one trip fault and should have been a two trip fault:

- P049D – EGR control position exceeded learning limit
- P0711 – Transmission temperature sensor performance
- P0712 – Transmission temperature sensor low
- P0713 – Transmission temperature sensor high
- P0714 – Transmission temperature sensor intermittent
- P0740 – TCC out of range
- P0869 – Line pressure high
- P0933 – Hydraulic pressure sensor range/performance
- P0934 – Line pressure sensor circuit low
- P0935 – Line pressure sensor circuit high
- P1775 – Solenoid switch valve latched in TCC position
- P1776 – Solenoid switch valve latched in LR position
- U0100 – Lost communication with ECM/PCM
- U0002 – Can C bus off performance – bus off

Improvements to prevent or reduce unnecessary Malfunction Indicator Lamp (MIL) illumination for:

- P026A – Charge air cooler efficiency below threshold
- P0544 – Exhaust gas temperature sensor circuit – Bank 1 Sensor 1
- P0562 – Battery voltage low
- P20EE – SCR NOx catalyst efficiency below threshold – Bank 1 (additional software enhancements to prevent false MIL)
- P2201 – Aftertreatment NOx sensor circuit performance – Bank 1 Sensor 1
- P2281 – Air leak between MAF and throttle body
- P24A5 – EGR cooler bypass Bank 1 control stuck
- P2459 – Diesel particulate filter regeneration too frequent (additional software enhancements to prevent false MILL)
- P249E – Closed loop SCR reductant injection control at limit – flow too high

Other Updates:

- With the ignition in the “Run” position, engine not running, a small number of customers may experience a message in the Vehicle Information Center that states “Service Exhaust System – see dealer” erroneously
- Doser thaw calibrations (with proper doser calibration ensure SB 18-xxx-13 (or later bulletin) is also completed to update Doser Control Unit (DCU)
- I/M OBD II readiness – DTC P2002 improvements help Particulate Matter (PM) filter monitor group to be set to ready more often
- Add engine run time to fuel filter minder
- Remove MIL for DTC; P1C70 – SCR error detected – engine disabled
- Frozen CAC diagnostic improvement
- WiTech – Reset fix (PTO request on pickup)
- WiTech – Road governor speed upper limit adjustment
- SCR performance test

This bulletin involves selectively erasing and reprogramming the Powertrain Control Module (PCM) with new software.

CATEGORY 18**VEHICLE PERFORMANCE**

TSB#	MODEL	SUBJECT/DESCRIPTION
18-022-13 5/22/13	'07-'09 DH/D1 '07-'10 DC/DM '10-'13 DJ/D2 '11-'13 DD '11-'12 DP	<p><i>Cummins 6.7L Turbo Diesel Common Diagnostic Process</i></p> <p>This bulletin applies to all vehicles equipped with the 6.7-liter Cummins Turbo Diesel engine.</p> <p>This common diagnostic process was developed for any drivability concern on the engine. Non-drivability engine issues or engine cooling system issues are not in the scope of this process.</p> <p>The process begins by identifying the customer's concern and applying it to one of the following symptoms:</p> <ul style="list-style-type: none">• MIL illumination• Engine cranks but does not start or starts and immediately stalls• Engine surges, bucks, runs rough – no MIL• Engine noise – no MIL• Excessive black smoke out exhaust – no MIL• Excessive white smoke out exhaust – no MIL• Excessive blue smoke out exhaust – no MIL <p>In each case, the test procedure will request that a Diesel diagnostic Worksheet be completed before proceeding. Once the data has been collected and analyzed, then the diagnostic process can continue.</p> <p>The worksheet takes the technician through several basic steps (fuel system checks, battery system checks, air filtration, previous flash updates) before the repair to the engine is started.</p>
18-025-13 7/2/13	'13 DD/DP	<p><i>Flash: Diagnostic and System Improvements</i></p> <p>Several software improvements are available for cab and chassis trucks built before 6/11/13. These improvements include:</p> <p>Improvements to prevent or reduce unnecessary Malfunction Indicator Lamp (MIL) illumination for:</p> <ul style="list-style-type: none">• P0234 – Turbocharger overboost condition• P026A – Charge air cooler efficiency below threshold• P0299 – Manifold pressure sensor out of range low• P0544 – Exhaust gas temperature sensor circuit – Bank 1 Sensor 1• P0562 – Battery voltage low• P20EE – SCR NOx catalyst efficiency below threshold – Bank 1• P2201 – Aftertreatment NOx sensor circuit performance – Bank 1 Sensor 1• P2281 – Air leak between MAF and throttle body• P24A5 – EGR cooler bypass Bank 1 control stuck• P2459 – Diesel particulate filter regeneration too frequent• P249E – Closed loop SCR reductant injection control at limit – flow too high <p>Other Updates:</p> <ul style="list-style-type: none">• With the ignition in the "Run" position, engine not running, a small number of customers may experience a message in the Vehicle Information Center that states "Service Exhaust System – see dealer" erroneously• Add engine run time to fuel filter minder• Remove MIL for DTC; P1C70 – SCR error detected – engine disabled• Wait To Start (WTS) bulb check timing improvements (1 second)• Set PTO maximum speed to 2,000 RPM• Allow Mobile PTO operation in neutral• Dual Fuel tank corrections• Dual alternator voltage variation improvements• Frozen CAC diagnostic improvement• WiTech – Reset fix (PTO request on pickup)• WiTech – road governor speed upper limit adjustment• SCR performance test <p>This bulletin involves selectively erasing and reprogramming the Engine Control Module (ECM) with new software.</p>

CATEGORY 18**VEHICLE PERFORMANCE****TSB#****MODEL****SUBJECT/DESCRIPTION**

18-026-13 '13 DJ/D2
7/2/13

Flash: Diagnostic and System Improvements

Several software improvements are available for consumer vehicles equipped with a Cummins Turbo Diesel. This bulletin applies to those trucks built before 6/11/13 that were equipped with an Aisin (DF2) or manual transmission (DEG).

Prevent or reduce unnecessary Malfunction Indicator Lamp (MIL) illumination for the following transmission faults. These faults are currently tripped as a one trip fault and should have been a two trip fault:

- P0711 – Transmission temperature sensor performance
- P0712 – Transmission temperature sensor low
- P0713 – Transmission temperature sensor high
- P0714 – Transmission temperature sensor intermittent
- P0740 – TCC out of range
- P0869 – Line pressure high
- P0933 – Hydraulic pressure sensor range/performance
- P0934 – Line pressure sensor circuit low
- P0935 – Line pressure sensor circuit high
- P1775 – Solenoid switch valve latched in TCC position
- P1776 – Solenoid switch valve latched in LR position
- U0100 – Lost communication with ECM/PCM
- U0002 – can C bus off performance – bus off

Improvements to prevent or reduce unnecessary Malfunction Indicator Lamp (MIL) illumination for:

- P026A – Charge air cooler efficiency below threshold
- P0544 – Exhaust gas temperature sensor circuit – Bank 1 Sensor 1
- P0562 – Battery voltage low
- P20EE – SCR NOx catalyst efficiency below threshold – Bank 1
- P2201 – Aftertreatment NOx sensor circuit performance – Bank 1 Sensor 1
- P2281 – Air leak between MAF and throttle body
- P24A5 – EGR cooler bypass Bank 1 control stuck
- P2459 – Diesel particulate filter regeneration too frequent (additional software enhancements to prevent false MIL)
- P249E – Closed loop SCR reductant injection control at limit – flow too high

Other Updates:

- With the ignition in the “Run” position, engine not running, a small number of customers may experience a message in the Vehicle Information Center that states “Service Exhaust System – see dealer” erroneously
- Add engine run time to fuel filter minder
- Remove MIL for DTC; P1C70 – SCR error detected – engine disabled
- Dual fuel tank corrections
- Frozen CAC diagnostic improvement
- WiTech – Reset fix (PTO request on pickup)
- WiTech – road governor speed upper limit adjustment
- SCR performance test

This bulletin involves selectively erasing and reprogramming the Powertrain Control Module (PCM) with new software.

18-0322-13 '13 DJ/D2
8/15/13

Flash: Doser Module, System Enhancements

Software improvements are available for the Diesel Exhaust Fluid (DRF) system on vehicles equipped with a Cummins Turbo Diesel. These improvements are designed to prevent or reduce unnecessary Malfunction Indicator Lamp (MIL) illumination for:

- P202E – (Diesel Exhaust Fluid) reductant injector performance

Service bulletin 18-018-13 (flash PCM) should be performed in conjunction with this bulletin.

CATEGORY 21 TRANSMISSION AND TRANSFER CASE

<u>TSB#</u>	<u>MODEL</u>	<u>SUBJECT/DESCRIPTION</u>
21-005-12 2/10/12	'12 DJ/D2/DD/DP	<p><i>Flash: Service 4WD Light Illuminated With C2201 Set</i></p> <p>This Service Bulletin applies to vehicles equipped with an electronic transfer case built before 1/6/2012. Some customers may get a "Service 4WD" light in the Cabin Compartment Node (CCN). Upon further investigation the Technician may find that C2201 – FDCM/DTCM Internal diagnostic trouble code (DTC) is set in the DTCM. When the system detects this, it shuts down the 4WD capability for the remainder of the drive cycle.</p> <p>This condition is not monitored when operating in 2WD mode. Updating the DTCM software will correct the conditions above.</p> <p>This bulletin involves flash reprogramming the Drive Train Control Module (DTCM) with new software.</p>

CATEGORY 25 EMISSIONS CONTROL

<u>TSB#</u>	<u>MODEL</u>	<u>SUBJECT/DESCRIPTION</u>
25-001-13 Rev A 5/10 13		<p><i>MIL Illumination due to P2000, P2A00 and/or P2A01</i></p> <p>This bulletin applies to vehicles equipped with a 6.7L Cummins Diesel engine (sales code ETJ) built before 8/2/2010. Customer may experience MIL illumination. Further investigation by the technician may find one or more of the following DTC(s) present:</p> <ul style="list-style-type: none">P2000 – NOx absorber efficiency below Threshold – Bank 1P2A00 – O2 Sensor 1/1 circuit performanceP2A01 – O2 Sensor 1/2 circuit performance <p>This bulletin involves inspecting both Oxygen (O2) sensors and either cleaning or replacing the sensors and installing an O2 Sensor Heat Shield on the exhaust pipe in the area in the FRONT O2 sensor.</p>
25-002-13 2/28/13	'11 DD/DP	<p><i>MIL Illumination Due To P1C56 – NOx Sensor Intermittent – Bank 1 Sensor 2</i></p> <p>Customer may experience MIL illumination. Further investigation by the technician may find P1C56 – NOx sensor Intermittent – Bank 1 Sensor 2 is set active or stored.</p> <p>This condition may be caused by insufficient heat retention in the exhaust at or near the DEF doser.</p> <p>This bulletin involves verifying excessive Diesel Exhaust Fluid (DEF) deposits in the decomposition tube collected and if present, replacing the Catalytic Converter Shield with a "clam shell" shield with a metal exterior.</p>

CATEGORY 25**EMISSIONS CONTROL**

<u>TSB#</u>	<u>MODEL</u>	<u>SUBJECT/DESCRIPTION</u>
25-004-13 8/15/13	'10-'12 DJ/D2	<p><i>Malfunction Indicator Lamp Illumination Due To Oxygen Sensor</i></p> <p>If the vehicle has any of the following DTC's for O2 sensors, stored, pending or active, perform the repair procedure.</p> <ul style="list-style-type: none"> • P013A O2 Sensor 1/2 Slow Response – Rich To Lean • P013B O2 Sensor 1/2 Slow Response – Lean To Rich • P013C O2 Sensor 1/1 Slow Response – Rich To Lean • P013D O2 Sensor 1/1 Slow Response – Lean To Rich • P0030 O2 Sensor 1/1 Heater Circuit • P0031 O2 Sensor 1/1 Heater Circuit Low • P0032 O2 Sensor 1/1 Heater Circuit High • P0036 O2 Sensor 1/1 Heater Circuit Malfunction • P0037 O2 Sensor Heater Circuit Low 1/2 • P0038 O2 Sensor Heater Circuit High 1/2 • P0053 O2 Sensor Heater 1/1 Resistance • P0054 O2 Sensor Heater 1/2 Resistance • P064D Internal Control Module O2 Sensors Processor Performance – Bank 1 • P0131 1/1 O2 Sensor Shorted To Ground • P0132 1/1 O2 Sensor Shorted To Voltage • P0135 O2 Sensor 1/1 Heater Performance • P0137 1/2 O2 Sensor Shorted To Ground • P0138 1/2 O2 Sensor Shorted To Voltage • P0141 O2 Sensor 1/2 Heater Performance • P113C O2 Sensor Power Supply Circuit Performance • P2195 O2 Sensor 1/1 Out Of Range High • P2196 O2 Sensor 1/1 Out Of Range Low • P22AB O2 Sensor Positive Current Control Circuit/Open – Bank 1 Sensor 2 • P22AE O2 Sensor Reference Voltage Control Circuit/Open – Bank 1 Sensor 2 • P22B2 O2 Sensor Negative Current Control Circuit/Open – Bank 1 • P22B5 O2 Sensor 1/2 Pump Cell Current Trim Circuit Open • P2237 O2 Sensor 1/1 Pump Cell Current Circuit Low • P2243 O2 Sensor 1/1 Reference Voltage Control Open • P2251 O2 Sensor 1/1 Negative Current Control Circuit/Open • P2270 O2 Sensor 1/2 Out Of Range High • P2271 O2 Sensor 1/2 Out Of Range Low • P241A O2 Sensor 1/1 And 1/2 Oxygen Concentration Mismatch • P2626 O2 Sensor 1/1 Pump Cell Current Trim Circuit/Open • P2A00 O2 Sensor 1/1 Circuit Performance • P2A00 O2 Sensor 1/2 Circuit Performance • U011A Lost Communication With Exhaust Gas Sensor Module

The repair procedure requires that both Oxygen Sensor connectors should be removed and new connectors with pigtailed installed. The pigtail splice points should be staggered to eliminate bulk in the harness.

CATEGORY 31**COLLISION BULLETIN**

<u>TSB#</u>	<u>MODEL</u>	<u>SUBJECT/DESCRIPTION</u>
31-001-13 1/11/13	All	<p><i>Overspray Removal</i></p> <p>This bulletin describes the proper procedure for removing overspray which can be a result of industrial fallout and/or a poor refinishing process.</p> <p>Depending on the severity and extent of overspray on painted surfaces, the removal process will vary. Always begin using the least aggressive method. The bulletin discusses use of Meguiar's products to refinish and polish the paint.</p>
31-002-13 1/31/13	All	<p><i>Blending Clearcoat During The Refinish Process</i></p> <p>This bulletin discusses Chrysler's position against the use of partial clearcoat blending.</p> <p>Partial clearcoat blending is not an approved warranty repair process for Chrysler vehicles. Clearcoat should always be applied to the entire surface area of a body panel and mixed to manufacturer's specifications. Any vehicle repaired with the partial clearcoat blending process will prematurely fail and eventually result in a clearcoat delaminating condition.</p>

2013 RECALL NOTICES

SAFETY RECALL N19 ENGINE COVER

Date: August 2013

Models/Production:

'13 (DJ) 2500 Pickup

'13 (D2) 3500 Pickup

This recall applies only to the above vehicles built through February 22, 2013. Many of the vehicles within the above build period have already been inspected or repaired.

Subject: The engine cover on about 6,100 of the above vehicles may experience a condition where it insulates the area on the passenger side of the engine. This could cause engine components under the engine cover to overheat and possibly cause an underhood fire.

Repair: The engine cover must be replaced.

SAFETY RECALL N26 FRONT AXLE TUBE WELDS

Model/Production:

'12 (DD) 3500 Chassis Cab

'12 (DP) 4500/5500 Chassis Cab

This recall applies to some 2012 model year Ram 4500/5500 series trucks equipped with four-wheel drive.

Subject: The front axle differential housing may rotate relative to the front axle tubes due to improper welds. This may cause the front propeller shaft universal joint, at the front axle, to bind up or fracture.

SAFETY RECALL N33 PREMIUM HEADLAMP AIM & INTENSITY

Date: July 2013

Model/Production:

'13 (DJ) 2500 Pickup Truck

'13 (D2) 3500 Pickup Truck

This recall applies only to the above vehicles equipped with BI-function halogen projector headlamps (sales code LMC) built at the Saltillo Truck Assembly Plant ("G" in the 11th VIN Position) through February 25, 2013. Many of the vehicles within the above build period have already been inspected or repaired and, therefore, have been excluded from this recall.

Subject: The premium headlamps on about 1,070 of the above vehicles were not properly configured, for high beam aim and intensity, in the Body Control Module (BCM). A reduced high beam intensity is typically the problem.

Repair: The BCM must be reconfigured/reprogrammed.

SAFETY RECALL N35 REPROGRAM BODY CONTROL MODULE

Date: June 2013

Model/Production:

'13 (DS) 1500 Pickup Truck

'13 (DJ) 2500 Pickup Truck

'13 (D2) 3500 Pickup Truck

This recall applies only to the above vehicles equipped with premium headlamps (sales code LAD or LAE) built at the Saltillo Truck Assembly Plant ("G" in the 11th VIN Position) through February 26, 2013. Many of the vehicles within the above build period have already been inspected or repaired and, therefore, have been excluded from this recall.

Subject: The Body Control Module (BCM) on about 17,200 of the above vehicles may not give the double-flash cluster notification of a turn signal malfunction.

Repair: The body Control Module (BCM) must be reprogrammed (flashed).

SAFETY RECALL N41 TRACK BAR-TO-FRAME BOLT

Date: August 2013

Model/Production:

'13 (DP) 4500/5500 Cab Chassis

This recall applies only to the above vehicles equipped with four wheel drive built from January 22, 2013, through March 08, 2013. Many of the vehicles within the above build period have already been inspected or repaired and, therefore, have been excluded from this recall.

Subject: the front suspension track bar-to-frame bolt on about 700 of the above vehicles may be the incorrect length. This could cause the bolt to break and/or fall out while driving, leading to a loss of directional control and possible crash without warning.

Repair: The track bar-to-frame bolt length must be inspected. Vehicles found with a track bar-to-frame bolt that is too short or missing must have the track bar-to-frame bolt replaced.

TECHNICAL SERVICE BULLETINS ISSUED DURING 2014

CATEGORY 8 ELECTRICAL

Editor's Comments: Section 8/Electrical – Radios and Media Center Units

Wow! As I mentioned, were it not for reprogramming radio units, our list of TSBs for 2014 would be very small. As you look through the following you'll see what I mean.

And, from conversations with suppliers to Chrysler, I know it is expensive to have a TSB issued due to a flash or electronic update being necessary. So, who makes the Chrysler radio/media center unit? Do we purchase vehicles or do we purchase infotainment on four wheels? Makes you wonder...

To start the summary, here is a TSB from 2013 that I missed. It will be followed by three others that were issued in 2013 after we sent our magazine to be printed in the fall, then the balance of new TSBs that were released thus far in 2014.

<u>TSB#</u>	<u>MODEL</u>	<u>SUBJECT/DESCRIPTION</u>
08-027-13 Rev A 7/25/13	'13 DS/DP/ DJ/DD/D2	<p><i>Flash: Memory Seat Module Message, Memory Recall Not Available</i></p> <p>The bulletin applies to vehicles built on or before April 02, 2013 with seat memory codes LEV or LEL. The problem typically shows up as an intermittent message "Memory recall not available" without pressing the memory seat button. On further inspection, the technician will not find any DTC. After updating the software in the MSM, the only time you will see "Memory recall not available-Vehicle not in park" is when the vehicle is out of park and the memory seat button is pressed.</p> <p>The repair involves a flash/update to the memory seat module (MSM) software.</p>
08-075-13 9/26/13	'13-'14 DS/DJ/ D2/DD/DP	<p><i>Radio Locks Up Intermittently On Rough Roads</i></p> <p>Customers may experience the radio and touchscreen will lock up intermittently, most often while driving on rough roads. No DTCs will be found. This bulletin applies to vehicles built on or after June 25, 2013 and on or before August 12, 2013 equipped with 8.4" touch screen display. The repair involves removing a burr from the integrated center stack bezel.</p>
08-086-13 10/30/13	All	<p><i>Exterior Lamp Condensation and Fogging</i></p> <p>Customers may report that on occasion, vehicle exterior lamp assemblies are fogged with a light layer of condensation on the inside of the lenses. This will usually clear as atmospheric conditions change to allow the condensation to change back into a vapor. Turning the lamps on will usually accelerate this process.</p> <p>A lamp that exhibits condensation/fogging should be evaluated in a service bay environment. If the condensation/fogging has begun to clear from the lamp lens after 20 minutes with the lamps operating, this indicates the lamp sealing has not been breached, and the lamp does not need to be replaced.</p> <p>This information-only bulletin was released to the dealerships to help them properly evaluate the situation.</p>

CATEGORY 8**ELECTRICAL**

<u>TSB#</u>	<u>MODEL</u>	<u>SUBJECT/DESCRIPTION</u>
08-089-13 712/03/13	'13 DS/DJ/ D2/DD/DP	<p><i>Poor Sirius Satellite Radio Reception</i></p> <p>Customers may experience that their satellite radio has intermittent muting. This occurs in areas where the signal is degraded and cell signal is very weak. The problems are worse when the optional vehicle internet connection through the cell network is in use with the internal vehicle Wi-Fi.</p> <p>This bulletin applies to DS vehicles built on or before October 31, 2013; DJ/DD/DP/D2 vehicles built on or before October 17, 2013 that are equipped with Sirius XM Satellite Radio (sales code RSD) and Connected Vehicle (sales code RS7).</p> <p>This bulletin involves replacing the satellite antenna, if needed.</p>
08-001-14 1/03/14	'13-'14 DJ/DD/ D2/DP	<p><i>Flash: Activate the Disable Feature for Hill Start Assist and PTO Enhancement</i></p> <p>Customers may notice the feature to disable hill start assist is missing in the cluster. Vehicles that are equipped with PTO, intermittently the system may not operate. On further inspection no DTC will be found.</p> <p>This bulletin applies to vehicles built on or before October 15, 2013; DP vehicles equipped with Anti-Lock 4-Wheel Disc Brake and other vehicles equipped with Electronic Stability Control.</p> <p>This bulletin involves updating the Anti-Lock Brake System (ABS) module software.</p>
08-002-14 1/07/14	'13-'14 DS/DJ/ DD/D2/DP	<p><i>Flash: Can Not Disable Comfort Auto On Feature</i></p> <p>Customers may experience not being able to turn off the "Comfort Auto On" feature in the customer settings.</p> <p>This bulletin applies to vehicles built on or before August 24, 2013 equipped with Heated Front Seats.</p> <p>This bulletin involves updating the Heated Seat Module (HSM) software.</p>
08-006-14 1/18/14	'14 DJ/D2	<p><i>Mirrors Will Not Adjust Correctly When In the Trailer Tow Position</i></p> <p>Customers may experience when the mirrors are fully open to the trailer tow (up-right) position and when they try to adjust the horizontal/vertical position, the mirrors will move backward to the switch input. The mirrors will move correctly when in the normal (down) position.</p> <p>This bulletin applies to vehicles built on or after October 10, 2013 or before November 02, 2013 equipped with Power Black Trailer Tow Mirror W/Memory (sales code GPK).</p> <p>This bulletin involves reconfiguring the vehicle for proper operation of the Trailer Tow Mirrors.</p>
08-010-14 1/30/14	'13 DS/DJ/ D2/DD/DP	<p><i>Cruise Control Slow or No Response</i></p> <p>Customers may experience no response or slow response to cruise control switch activations. Issues will be experienced by the customers that activate/press the switches in a very fast manner.</p> <p>This bulletin applies to vehicles built on or before May 01, 2013 equipped with Speed Control (sales codes NHM).</p> <p>This bulletin involves upgrading the software on the Steering Column Control Module.</p>
08-015-14 2/12/14	'13 DJ/D2/ DD/DP	<p><i>Diesel Message Display in the Cluster May Have Overlapping Text</i></p> <p>Customers may notice that some of the text in the cluster for the Diesel Exhaust fluid (DEF) reminder is overlapping.</p> <p>This bulletin applies to vehicles built on or after January 01, 2012 on or before May 02, 2013 equipped with the Laramie Longhorn Instrument Cluster (sales code JAX) or Electroluminescent Instrument Cluster (sales code JA6).</p> <p>This bulletin involves replacing the Instrument Panel Cluster (IPC).</p>

CATEGORY 8**ELECTRICAL**

TSB#	MODEL	SUBJECT/DESCRIPTION
08-020-14 2/25/14	'13-'14 DS/DJ/D2	<p>Flash: Radio May Be Muted, Caused By the Amplifier Not Communicating</p> <p>Customers may indicate that there is no audio and/or radio is muted. This condition may be caused by the amplifier not communicating on the bus. On further inspection, U0186-00 lost communication with the audio amplifier may be found.</p> <p>This bulletin applies to vehicles built on or before January 22, 2014 equipped with 9 Amplified Speakers W/Subwoofer (sales code RD3) or 506 Watt Amplifier (sales code RFD)</p> <p>This bulletin involves updating the Amplifier's software.</p>
08-025-14 3/05/14	'14 DS/DJ/ D2/DD/DP	<p>Flash: Inaccurate outside Temperature Display</p> <p>Customers may notice that the temperature display will be cooler than the actual outside temperature (up to 20° lower). This condition is more noticeable the colder the temperature gets.</p> <p>This bulletin applies to vehicles built on or after November 01, 2013 on or before January 14, 2014 equipped with sales code JP3 or sales code JPY power windows.</p> <p>This bulletin involves updating the Driver and Passenger Door Module (DDM and PDM) if required.</p>
08-034-14 3/20/14	'14 All	<p>Diagnostic: Radio and Navigation Unit Updates</p> <p>This bulletin involves confirming that the radio is at the most current software version to assist in the diagnosis and repair of Radio and NAV units. Then validating that the symptom/condition was repaired with the latest update.</p>
08-035-14 3/22/14	'14 DS/DJ/ D2/DD/DP	<p>Missing: Tailgate Keyless Entry with Back-Up Camera Wiring Kit</p> <p>This bulletin involves placing the missing wire harnesses in the glove box for later installation. It applies to vehicles built after July 1, 2013 or before September 10, 2013 with Remote Keyless Entry (sales code GXM) and/or Parkview(TM Rear Back-Up Camera (sales code XAC).</p>
08-036-14 Rev A 7/31/14	'13-'14 DS/DJ/ D2/DD/DP	<p>RA3 RA4 Radio Enhancements</p> <p>This bulletin applies to vehicles equipped with one of the following radios.</p> <ul style="list-style-type: none">• Uconnect 8.4A AM/FM BT/ACCESS (sales code RA3)• Uconnect 8.4AN AM/FM BT/ACCESS/NAV (sales code RA4) <p>In the bulletin, there were numerous radio faults/problems listed (64 different items). The repair involves inspecting and updating the radio software, if required.</p>
08-045-14 Rev A 5/30/14	'13-'14 DS	<p>Flash: Air Suspension Message Battery Voltage Low</p> <p>Customers may notice a false message "Battery Voltage Low – Start Engine to Change Ride Height" which appears in the Electronic Vehicle Information Center (EVIC) when unlocking or locking the doors. A battery drain may happen when using the key fob to stop the vehicle from lowering. The ASCM does not go to sleep and the CAN-C bus stays awake.</p> <p>This bulletin applies to vehicles built on or before May 10, 2014 equipped with Quadra-Lift (TM) Air Suspension (sales code SER).</p> <p>This bulletin involves updating the Air Suspension Control Module (ACSM) software.</p>
08-063-14 8/02/14	'14 DS	<p>Incorrect Battery</p> <p>Customers may experience a slow crank during very cold temperatures. On further inspection, it may be found that the vehicle has the incorrect battery.</p> <p>This bulletin applies to vehicles built on or after March 13, 2014 on or before June 21, 2014 equipped with diesel engine (sales code EXF).</p> <p>This bulletin involves inspecting to see if the vehicle has the correct battery and replacement, if required. The dealer is directed to open the hood and inspect the battery. H7 (730 Cold Cranking Amps (CCA) battery is the incorrect one. The correct battery will have one of these parts numbers: BA00L5858W (Canada only) or BBAH880AA (all other vehicles).</p>

CATEGORY 14 FUEL SYSTEM

<u>TSB#</u>	<u>MODEL</u>	<u>SUBJECT/DESCRIPTION</u>
14-001-14 Rev A 3/04/14	'13-'14 DJ/D2/ DD/DP	<i>Fuel Gelling in Cold Ambient Temperatures</i> Customers may experience a Malfunction Indicator Lamp (MIL) due to fuel related Diagnostic Trouble Code (DTC) and/or may have a hard or no start condition due to fuel gelling in cold ambient temperatures (20° or below). DTC's, such as P0087, P0191 or P026B (or other DTC's) may have been set. The above concerns have a condition that will cause the frame mounted fuel filter heater not to function. The condition is due to a configuration setting in the Body Control Module (BCM), not an inoperative fuel heater.

This bulletin applies to trucks built before 12/14/13.

This bulletin involves reconfiguring the Body Control Module (BCM).

CATEGORY 18 VEHICLE PERFORMANCE

<u>TSB#</u>	<u>MODEL</u>	<u>SUBJECT/DESCRIPTION</u>
18-052-13 11/27/13	'14 DJ/D2	<i>Flash: Diagnostic and System Improvements</i> Several software improvements are available for vehicles equipped with a Cummins 6.7L Turbo Diesel engine.

Prevent or reduce unnecessary Malfunction Indicator Lamp (MIL) illumination for the following transmission faults. These faults are currently tripped as a one trip fault and should have been a two trip fault:

- P049D – EGR Control Position Exceeded Learning Limit
- P226C – Turbo Charger Boost Control “A” Slow Response

Improvements to prevent or reduce unnecessary Malfunction Indicator Lamp (MIL) illumination for:

- P04DB – Crankcase Ventilation System is Connected
- P1C55 – NOx Sensor Intermittent – Bank 1 Sensor 1
- P20EE – SCR NOx Catalyst Efficiency Below Threshold – Bank1
- P2002 – Diesel Particulate Filter Efficiency Below Threshold
- P0604 – Internal Control Module Ram
- P1451 – Diesel Particulate Filter System Performance

Other Updates:

- Doser Thaw Calibrations (with proper doser calibration). Ensure SM 18-032013 (or later bulletin) is also completed to update Doser Control Unit (DCU)
- I/M OBD II readiness – DTC P2002 improvements help Particulate Matter (PM) filter monitor group to be set to ready more often
- Grid Heater inhibit operation correction
- Add engine run time to fuel filter minder
- Dual alternator WiTech improvements
- Inducement timer reset procedure improvement
- DEF refill detection calibration improvement

This bulletin involves selectively erasing and reprogramming the Powertrain Control Module (PCM) with new software.

CATEGORY 18**VEHICLE PERFORMANCE**

TSB#	MODEL	SUBJECT/DESCRIPTION
18-002-14 1/17/14	'14 DD/DP	<p><i>Flash: Diagnostic and System Improvements</i></p> <p>Several software improvements are available for vehicles equipped with a Cummins Turbo Diesel engine.</p> <p>Prevent or reduce unnecessary Malfunction Indicator Lamp (MIL) illumination for the following Diagnostic Trouble Codes (DTCs). These DTCs are currently tripped as a one trip fault and should have been a two trip fault:</p> <p>P049D – EGR Control Position Exceeded Learning Limit</p> <p>Improvements to prevent or reduce unnecessary Malfunction Indicator Lamp (MIL) illumination for:</p> <p>P202E – (Diesel exhaust fluid) Reductant Injector Performance P20EE – SCR NOx Catalyst Efficiency Below Threshold – Bank1 P2002 – Diesel Particulate Filter Efficiency Below Threshold P0604 – Internal Control Module Ram Error. This DTC may be caused by enabling the remote throttle feature via the EVIC, and it will be accompanied by a “service electronic throttle control” message in the EVIC.</p> <p>Other Updates:</p> <ul style="list-style-type: none"> • OBD Template changes for P2453 • Fuel Filter Minder Calibration Changes • Dual Fuel Tank component update • Inducement Timer Reset (Feature enable in WiTech) • PTO Denied Status Message Update • PTO Horn Request sent to Body Control Unit (BCU) • Wait To Start (WTS) bulb check timing improvements (1 second) • Frozen CAC Diagnostic Improvement
18-010-14 2/20/14	'13-'14 DJ/D2/ DD/DP	<p><i>Flash: Doser Module, MIL Illumination P208D and or P202E</i></p> <p>This bulletin applies to trucks built before 2/20/2014. This bulletin involves selectively erasing and reprogramming the Doser Control Unit (DCU) with new software.</p>
18-028-14 Rev A	'14 DS	<p><i>Flash: MIL Illumination – Diagnostic and System Improvements</i></p> <p>This bulletin applies to DS vehicle equipped with a 3.0 diesel engine built on or before 3/31/2014. Customers may experience an erroneous Malfunction Indicator Lamp (MIL) illumination. These MIL codes range from P0045 up to P2565. A reflash of the powertrain control module with new software solves the annoying problem.</p>
18-030-14 4/12/14	'13 DJ/D2	<p><i>Flash: Diagnostic and System Improvements</i></p> <p>Several software improvements are available for vehicle equipped with a Cummins Turbo Diesel engine.</p> <p>Prevent or reduce unnecessary Malfunction Indicator Lamp (MIL) illumination for the following transmission faults. These faults are currently tripped as a one trip fault and should have been a two trip fault:</p> <p>P0201 - P0206 – Fuel Injector X Circuit/Open P049D – EGR Control Position Exceeded Learning Limit P0711 – Transmission Temperature Sensor Performance P0712 – Transmission Temperature Sensor Low P0713 – Transmission Temperature Sensor High P0714 – Transmission Temperature Sensor Intermittent P0740 – TCC Out of Range P0869 – Line Pressure High P0933 – Hydraulic Pressure Sensor Range/Performance P0934 – Line Pressure Sensor Circuit Low P0935 – Line Pressure Sensor Circuit High P1775 – Solenoid Switch Valve Latched in TCC Position P1776 – Solenoid Switch Valve Latched in LR Position U0100 – Lost Communication With ECM/PCM U0002 – Can CA Bus Off Performance – Bus Off U110E – Lost Ambient Temperature Message</p>

<u>TSB#</u>	<u>MODEL</u>	<u>SUBJECT/DESCRIPTION</u>
18-030-14 <i>continued</i>		<p>Improvements to prevent or reduce unnecessary Malfunction Indicator Lamp (MIL) illumination for:</p> <ul style="list-style-type: none"> P026A – Charge Air Cooler efficiency Below Threshold P04DB – Crankcase Ventilation System Disconnected P0544 – Exhaust Gas Temperature Sensor Circuit – Bank 1 Sensor 1 P0562 – Battery Voltage Low P0604 – Internal Control Module Ram Error P1451 – Diesel Particulate Filter System Performance P20EE – SCR NOx Catalyst Efficiency Below Threshold – Bank 1 Sensor 1 (Additional software enhancements to prevent false MIL) P202E – (Diesel Exhaust Fluid) Reductant Injector Performance P2201 – Aftertreatment NOx Sensor Circuit Performance – Bank 1 Sensor 1 P2281 – Air Leak Between MAF and Throttle Body P24A5 – EGR Cooler Bypass Bank 1 Control Stuck P2459 – Diesel Particulate Filter Regeneration Too Frequent (Additional software enhancements to prevent false MIL) P249E – Closed Loop SCR Reductant Injection Control at Limit – Flow Too High <p>Other Updates:</p> <ul style="list-style-type: none"> • With the ignition in the “Run” position, engine not running, a small number of customers may experience a message in the Vehicle Information Center that states “Service Exhaust System – See Dealer” erroneously. • Doser Thaw Calibrations (with proper doser calibration). Ensure SB 18-032-13 (or later bulletin) is also completed to update Doser Control Unit (DCU) • I/M OBD II readiness – DTC Ps00s improvements help Particulate Matter (PM) Filter monitor group to be set to ready more often • Add engine run time to fuel filter minder • Remove MIL for DTC; P1C70 – SCR Error Detected – Engine Disabled • Frozen CA diagnostic improvement • WiTECH – reset fix (PTO request on Pickup) • WiTECH – Road governor speed upper limit adjustment • SCR Performance test fix • DEF Refill detection calibration change • Grid heater inhibit correction • P0544 – Exhaust Gas Temperature Sensor Circuit – Bank 1 Sensor 1 – Does not clear correctly • Fuel filter minder distance trigger correction • Fuel system test improvements • Exhaust brake switch improvement • Cold idle stability improvement • Add ability to reset soot load after DPF replacement • Correction condition – Cruise control does not cancel at key off • U12A 4 – Lost Communication With Ammonia Sensor – Change to a 1 Trip MIL <p>This bulletin involves selectively erasing and reprogramming the Powertrain Control Module (PCM) with new software.</p>

CATEGORY 18 VEHICLE PERFORMANCE

<u>TSB#</u>	<u>MODEL</u>	<u>SUBJECT/DESCRIPTION</u>
18-038-14 7/19/14	'13-'14 DD/DP	<i>Engine Shutdown Timer Feature function Improvement</i> Some vehicles did not have the "Engine Auto Shutdown timer Limit" adjusted or enabled properly at the factory. This bulletin will correct this issue.
18-039-14 7/19/14	'14 DD/DP	<i>PTO Feature Function Improvement</i> This bulletin applies to trucks equipped with Power Take Off (PTO) sales codes LBN or LBV. Customers are not able to select Power Take OFF (PTO) functionality because the option selection menu is missing from the commercial menu (EVIC selection). This bulletin involves reconfiguring the vehicle.

CATEGORY 21 TRANSMISSION AND TRANSFER CASE

<u>TSB#</u>	<u>MODEL</u>	<u>SUBJECT/DESCRIPTION</u>
21-005-14 2/15/14	'13 D2/DD/DP	<i>Flash: Transmission Shift Enhancements</i> This bulletin applies to vehicles equipped with the Aisin AS69RC Automatic Transmission (sales code DF2). The customer may indicate that they may have experienced any of the following: <ul style="list-style-type: none">• Harsh 2-1 downshift• Delayed shifts while shifting from neutral to drive, neutral to reverse, or park to reverse• Audible squawk noise while the truck is shifting from 4-3• Poor vehicle acceleration in first gear while fully loaded In addition to any of the previous, dealers may identify a P253D "PTO Sense Circuit High" stored in the TCM's memory. This bulletin involves selectively erasing and reprogramming the Transmission Control Module (TCM) with new software.
21-012-14 Rev A 7/09/14	'13-'14 DS	<i>Transmission Shift Enhancements – Adaptation Drive Learn Procedure</i> This bulletin applies to vehicles equipped with the 8HP70 8-Speed Automatic Transmission (sales code DFD). The 845RE, 8HP45, or the 8HP70 8-Speed Automatic Transmission uses a sophisticated shift algorithm that includes learned information so that the shift quality remains excellent even as the transmission wears. This bulletin involves performing a subjective shift quality rating when customers experience poor shift quality and if necessary, performing the transmission adaptation learn procedure. In addition, this bulletin involves performing transmission adaptation learn procedure when the transmission is repaired/replaced and/or the valve body/TCU assembly (mechanronic) is replaced, or when the adaptation memory cells are cleared with the WiTech diagnostic scan tool.
21-015-14 4/17/14	'14 D2/DD/DP	<i>Flash: Transmission Shift Enhancements</i> This bulletin applies to vehicles equipped with the Aisin AS69RC Automatic Transmission (sales code DF2) built before March 15, 2014. The customer may indicate that they experience a harsh 2-1 downshift. This bulletin involves selectively erasing and reprogramming the Transmission Control Module (TCM) with new software.

CATEGORY 22 TIRES AND WHEELS

<u>TSB#</u>	<u>MODEL</u>	<u>SUBJECT/DESCRIPTION</u>
22-001-14 2/19/14		<i>Steering Wheel Vibration at Highway Speeds</i> This bulletin describes the procedure for road testing, tire balance measuring, road force variation and flat spotting removal.
22-002-14 Rev A		<i>Tire Flat Spotting Identification, Prevention and Resolution</i> Temporary tire Flat Spotting is common on New Dealer In-Stock vehicles that have not been occasionally repositioned. This bulletin involves identifying, preventing and eliminating tire flat spotting.

CATEGORY 23 BODY

<u>TSB#</u>	<u>MODEL</u>	<u>SUBJECT/DESCRIPTION</u>
23-018-14 7/11/14	'13-'14 DS/DJ/DP	<i>Armrest Storage Compartment Lid Difficult To Latch</i> The problem is that the front center seat armrest storage compartment lid is difficult to latch due to hard lid bumpers. This bulletin applies to vehicles built on or after January 28, 2013 and before October 10, 2013 equipped with 40/20/40 Split Bench Seat (sales codes CBE). This bulletin involves replacing the front center seat armrest storage compartment lid bumpers.

CATEGORY 24 HEATING & AIR CONDITIONING

<u>TSB#</u>	<u>MODEL</u>	<u>SUBJECT/DESCRIPTION</u>
24-001-14 3/11/14	'14 DP	<i>Flash: Front Defrost Button Does Not Respond At Times</i> This bulletin applies to vehicles equipped with an 8.4 inch touchscreen display (sales code RFL) built on or before January 27, 2014. Customers may experience a situation where the touch screen climate controls may ignore the first press of the front defrost button if it is the first climate button pressed after ignition ON. The second press of the front defrost button works correctly. If another climate button is pressed prior to the front defrost button, the control will respond as desired. This bulletin involves selectively erasing and reprogramming the HVAC control module with new software.

CATEGORY 25 EMISSIONS CONTROL

<u>TSB#</u>	<u>MODEL</u>	<u>SUBJECT/DESCRIPTION</u>
25-002-14 8/01/14	'10-'12 DJ/D2	<i>Malfunction Indicator Lamp Illumination Due To Oxygen Sensor</i> This bulletin supersedes service bulletin 25-003-13, dated March 01, 2013 and 25-004-13, dated August 15, 2013, which should be removed from your files. This is a complete revision. This bulletin involves the installation of an Oxygen (O ₂) Sensor Overlay Harness for any Oxygen Sensor related DTC(s). The Overlay Harness will consist of twelve 18 AWG wires (six from each Oxygen Sensor) that run to a new Oxygen Sensor Module connector. Four wires will be removed from the original vehicle O ₂ Module connector and installed in the new overlay harness O ₂ Module connector.

2014 RECALL NOTICES

CALIFORNIA EMISSIONS RECALL K01 REPROGRAM ECM—OBD READINESS

Date: May 2010

Models: '03 (DR) Dodge Ram 2500/3500 Pickup Truck

'06-'07 (DH/D1) Dodge Ram 2500/3500
Pickup Truck

'07 (DC) Dodge Ram 3500 Cab/Chassis

This recall applies only to the above vehicles equipped with a 5.9-liter diesel engine (sales codes ETC and ETH) and a California emission control system (sales code NAE). And to above vehicles equipped with a 6.7-liter diesel engine (sales code ETJ) and a California emission control system (sales code NAE) built through January 5, 2007.

The Engine Control Module (ECM) on the above vehicles may fail to accurately report diagnostic system information with some generic scan tools. This may cause the vehicle to be rejected or fail an Inspection/Maintenance Test (also known as a Smog Check).

Repair: The Engine control Module (ECM) must be reprogrammed (flashed).

EMISSIONS RECALL J35 REPROGRAM ECM—REGENERATION STRATEGY

Date: April 2010

Models: '07.5-'09 (DH/D1) Dodge Ram 2500/3500
Pickup Truck

This recall applies only to the above vehicles equipped with a 6.7-liter diesel engine (sale code ETJ). The Engine Control Module (ECM) software program on the above vehicles may cause illumination of the Malfunction Indicator Lamp (MIL) when no problem exists or under certain conditions allow heavy sooting of the turbocharger, exhaust gas recirculation valve and diesel particulate filter. Heavy sooting could damage emissions components and result in increased emissions.

Repair: The Engine Control Module must be reprogrammed (flashed). The bulletin describes the service procedure that the dealership technician is to follow. Using the dealership's scan tools, the time allowance for the reprogramming operation is less than one hour. As a part of the recall and ECM update the technician has to verify that the previous emissions recall, recall G30, October 2007, has been performed. The G30 recall contains software that must be installed to prevent damage to the ECM. There are no parts involved in the J35 recall notice.

WWW.TECHAUTHORITY.COM A HIGHLY RECOMMENDED RESOURCE

After a five-year absence of providing the service of listing new technical service bulletins for a given year, the folks at TechAuthority (www.techauthority.com) have reinstated this service feature. This is both good and not-so-good for the TDR audience.

How so?

Good: It allows the editor to list only those TSBs issued during a given year. This cuts down on my research and trims the page count as we don't have to print a compilation of TSBs that go on for three or four years.

Not-so-good: As the owner you only get to see a limited, one-year window of bulletins printed in the magazine. How can we make this news to you more agreeable? First, realize that a compilation of the yearly TSB updates is always available to you at the TDR's web site under the listing of "TSBs." Second, if you want to search the TSBs the old-fashioned way you can go back to your printed magazines and look specifically at our annual summaries (starting with a progression of four) at 66, 62, 58, 54, etc.

Elsewhere in the magazine I've already talked about TechAuthority as an outstanding resource for information. The value of the information available for your truck's VIN at www.techauthority.com far exceeds the TechAuthority subscription price of \$20. Using your VIN (I even tried a '97 truck's VIN and got the information), you'll be able to pull up and print all the TSBs and recall notices specific to your truck. And, as mentioned on page 53, you'll be able to scroll through the entire factory service manual for your vehicle.

Robert Patton
TDR Staff

TECHNICAL SERVICE BULLETINS ISSUED DURING 2015

CATEGORY 2 FRONT SUSPENSION

<u>TSB#</u>	<u>MODEL</u>	<u>SUBJECT/DESCRIPTION</u>
02-001-15 1/10/15	All	<i>Shock Strut Weeping Condition Identification</i> The customer may describe fluid residue on the external surface of the strut or shock absorber. This information-only bulletin helps the dealer correctly diagnose strut or shock absorber conditions involving fluid residue on the external surface.
02-002-15 1/27/15	All	<i>Steering Wheel Not Centered</i> The customer may describe that the steering wheel is off center. This information-only bulletin describes the technique to properly diagnose and correct an off center steering wheel.
02-003-15 1/27/15	All	<i>Vehicle Pulls or Leads Right or Left</i> The customer may describe the vehicle pulls or leads right or left. This information-only bulletin describes the technique to properly diagnose and correct a lead/pull condition.

CATEGORY 8 ELECTRICAL

<u>TSB#</u>	<u>MODEL</u>	<u>SUBJECT/DESCRIPTION</u>
08-072-14 9/18/14	'13-'14 DS	<i>Intermittently the Vehicle Will Not Shift Out of Park</i> This bulletin applies to vehicles built on or before June 13, 2014 equipped with an 8-speed automatic transmission (sales code DFD/8HP70). The customer may experience not being able to shift out of park. This condition can be corrected by turning off the vehicle and allowing all of the modules to go to sleep. Once the modules have gone through a key cycle, the DTC will go from active to stored and then the vehicle can be shifted out of park. On further inspection, diagnostic trouble codes P0607 and P0928 may be found active or stored. The repair procedure involves replacing the electronic shifter module.
08-081-14 9/13/14	'13-'15 DS	<i>Diagnostic Trouble Code U11E9 After Fascia Removal</i> This bulletin applies to vehicles equipped with Active Grille Shutters (sales code MDX). The customer may describe that the malfunction indicator lamp (MIL) is illuminated after the vehicle is serviced. The technician may find diagnostic trouble code U11E9 is either active or stored. This bulletin involves confirming that the Active Grille Shutter (AGS) electrical harness connector is properly connected.
08-091-14 10/24/14	All	<i>Exterior Lamp Condensation and Fogging</i> Some customers may report that on occasion, vehicle exterior lamp assemblies are fogged with a light layer of condensation on the inside of the lenses. This may be reported after the lamps have been turned on and brought up to operating temperature, turned off, and then rapidly cooled by cold water (such as rain, or the water from a car wash). Lens fogging can also occur under certain atmospheric conditions after a vehicle has been parked outside overnight (i.e., a warm humid day followed by clear cool night). This will usually clear as atmospheric conditions change to allow the condensation to change back into a vapor. Turning the lamps on will usually accelerate this process.

CATEGORY 8**ELECTRICAL****TSB#****MODEL****SUBJECT/DESCRIPTION**

A lamp that exhibits condensation/fogging should be evaluated in a service bay environment by first drying all water from the outside surface of the lens and operating the lamp for 20 minutes.

If the condensation/fogging has begun to clear from the lamp lens after 20 minutes with the lamps operating, this indicates the lamp sealing has not been breached, and the lamp does not need to be replaced.

This bulletin gives the dealer the written guidelines for lens replacement.

08-016-15
Rev A
6/23/15

'13-'14 DS/DJ/
D2/DD/DP

Poor Radio Reception

This bulletin applies to vehicles equipped with Connected Vehicle (sales code RS7) and Sirius XM Satellite Radio (sales code RSD). DS vehicles built on or before October 31, 2013. DJ/DD/DP/D2 vehicles built on or before October 17, 2013. The bulletin involves replacing the satellite antenna if needed.

08-072-15
7/16/15

'13-'14 DS/DX/
DD/DJ/DP/D2

RA3 RA4 Radio Enhancements

This bulletin supersedes service bulletin 08-036-14 REV A dated July 31, 2014. This bulletin involves inspecting and updating the radio software. The bulletin applies to vehicles equipped with one of the following radios: Uconnect 8.4A sales code RA3, Uconnect 8.4AN sales code RA4.

A customer may experience one or more of the following conditions.

- Improved radio security protection to reduce the potential risk of unauthorized and unlawful access to vehicle systems (US market only).
- Track names may be displayed twice in USB or SD media modes.
- SD, USB or BTSA modes may become non-functional for a given ignition cycle.
- Duplicate song titles may be displayed in USB mode.
- Last track is displayed but next track is being played.
- Navigation function may reset itself after using One-Shot Voice Recognition (VR).
- Intermittently the Global Positioning System (GPS) may lose its location for a short time and cause routing and positioning concerns.
- GPS and internal cellular device may become inoperative and cause a loss of GPS and cellular functions.
- A false pop-up message may appear "Vehicle Phone Requires Service" even though the vehicle's phone works properly.
- Back-up camera image may be unclear or jittery/stutter at times.
- Enables via mobile software features when released to consumers. (US market only)
- Able to adjust audio balance/fade settings during a VR session.
- Correct condition where user could not exit screen off mode.
- Mute button status was not being displayed correctly.
- Presets where not shown correctly or were deleted.
- Enhancements to POI.
- ParkSense tone continuously on.
- Enhancement to navigation routing.
- Radio display may show "Please insert USB Stick."
- Enhancement made when video is display in radio when using PAL format video disks.
- Corrected the temperature slider bar not updating on Manual Temperature Control vehicles.
- Navigation may not start or may lose position.
- Rear camera may show a black screen for 3 seconds upon going into reverse.
- Enhancements for iPod or iPhone devices that may not start playing after connecting.

Continued on next page.

CATEGORY 8**ELECTRICAL**

8-072-15
7/16/15
continued

- iPod would not resume playing after a VR session or phone call.
- Radio reset, screen lockup, blank screen or sluggish system response time.
- Compass indicator turns off.
- Touch screen shut down message.
- Radio surround sound will not stay ON.
- Driver memory feature causes Sirius XM failure.
- Loss of radio presets.
- Battery drain – due to radio remaining on.
- Uconnect apps don't load.
- AM/FM popping noises and/or static.
- Backup camera display is blank.
- Compass direction may be incorrect.
- Vehicle's icon changes on the navigation map.
- Loss of vehicle position on NAV map.
- "Vehicle Phone Requires Service" message appears on 8.4" screen.
- NAV turn-by-turn enhancements.
- NAV map guidance enhancements.
- NAV text overlaps in detour menu.
- NAV map, vehicle location enhancements in areas with low GPS signals.
- Navigation shows vehicle in San Antonio, TX.
- Screen only displays startup Logo.
- Screen half black half white after update.
- Radio locked up after attempting to update with a corrupted or incorrect USB flash drive.
- Phone/Navigation Overlay Screen Freeze (WK only).
- Heated seat controls through radio do not function/display correctly during startup.
- Speed controlled volume not functioning correctly.
- Steering wheel control operation corrected at startup.
- Tuner mutes on startup.
- HD now defaults to 'OFF' for reduced complaints about 'channel switching'.
- "LO" temps displayed upon each vehicle start.
- HMI lock up in SXM mode after ignition cycle.
- Voice Recognition (VR) enhancements.
- Point of interest screen locks up.
- Error message when plugging in iPod.
- Balance/fade setting changes after ignition cycle.
- Clock enhancements.
- Phone book enhancements.
- Rear climate control display frozen.
- Translation enhancements.
- Erratic pop ups in HMI.
- Added Teleprompter.
- Blue tooth, phone, iPod, auto streaming, connecting/disconnecting enhancements.
- Phone quality and paring enhancements.
- Audio control locked after using VR feature.
- Travelling enhancements.

The repair procedure involves updating the radio to software version 15.26.1

CATEGORY 9**ENGINE**

TSB#	MODEL	SUBJECT/DESCRIPTION
08-097-14 11/13/14	' 1 3 - ' 1 4 DS/DJ/D2/DP	Mirror Tilt in Reverse Feature is Not Functioning Correctly This bulletin applies to vehicles equipped with Exterior Mirrors W/Memory (sales code LEM). The customer may describe one mirror tilting in reverse and the other mirror not tilting and/or the customer may describe not being able to turn the tilt in reverse feature on/off. This bulletin involves reprogramming the truck's body control module for proper mirror tilt in reverse operation.
09-006-15 7/18/15	'14 DS	Intermittent Engine Shudder While Driving This bulletin applies to vehicles equipped with the 3.0-liter Turbo Diesel. Customers may experience a slight engine shudder while driving. They may state that the condition feels and sounds like driving over rumble strips. It may also be perceived as an internal transmission issue or engine misfire. No diagnostic trouble codes will set as a result of this condition. The cause of the engine shudder has been found to be due to excess carbon build-up on the exhaust valve stems and will typically happen on vehicles driven mostly in light load conditions. As a result, new cylinder heads have been released that are equipped with newly designed valve stem seals. These newly designed seals are designed to help prevent excessive carbon from building up on the valve stems. Although it may be hard to reproduce, engine shudder resulting from these excess carbon deposits, will typically only happen under the following driving conditions. <ul style="list-style-type: none"> • Steady speeds between 50 and 70mph (80 and 113kph). • Engine speed between 1600-2000rpm. • Present during engine warm up to operating temperature after a cold soak. • Only present for a few seconds at a time and often during a 6.-7 upshift. • Light load acceleration or while driving up a slight grade. • Symptom will go away either by aggressively applying the accelerator pedal or going into a zero throttle deceleration. <p>The bulletin gives the repair procedure for replacing the cylinder heads.</p>

CATEGORY 18**VEHICLE PERFORMANCE**

TSB#	MODEL	SUBJECT/DESCRIPTION
Editor's comment: Oops, here is one that I missed from March of 2014. While it looks like a big deal, it is really nothing more than a checklist to do before the technician starts working on your Cummins Turbo Diesel engine.		
18-016-14 3/12/14	'07-'10 DC '11-'12 DD '07-'09 DH '10-'12 DJ '11-'12 DP '07-'10 DM '07-'09 D1 '10-'12 D2	Cummins 6.7-liter Turbo Diesel Common Diagnostic Process This bulletin applies to vehicles equipped with the 6.7-liter Cummins Turbo Diesel engine (equipped with a diesel particulate filter). This diagnostic process was developed for any drivability concern with the 6.7-liter engine. The process begins by identifying the customer's concern and applying it to one of the following symptoms: <ul style="list-style-type: none"> • MIL illumination • Engine cranks but does not start or starts and immediately stalls • Engine surges, bucks, runs tough – no MIL • Engine noise – no MIL • Excessive black smoke out exhaust – no MIL • Excessive white smoke out exhaust – no MIL • Excessive blue smoke out exhaust – no MIL <p>In each case, the test procedure will request that a 6.7-liter Diesel Diagnostic Worksheet be completed before proceeding. Once the data has been collected and analyzed, then the diagnostic process can continue.</p> <p>The process starts with the diagnostic worksheet. It continues with an inspection of the truck's fuel system and repair validation of the aftertreatment components. The technician continues the repair process using the appropriate prompts from TechCONNECT troubleshooting process.</p>

CATEGORY 18**VEHICLE PERFORMANCE**

<u>TSB#</u>	<u>MODEL</u>	<u>SUBJECT/DESCRIPTION</u>
18-045-14 11/21/14	'14 DS	<i>Diagnostic Trouble Code P20EE: SCR NOX Catalyst Efficiency Below Threshold Bank 1</i> This bulletin applies to vehicles equipped with a 3.0-liter diesel engine (sales code EXF) This bulletin involves verifying the proper operation of the diesel exhaust fluid (DEF) system and, if necessary, replacing the selective catalyst reduction (SCR) Catalyst assembly.
18-021-15 REV C 6/10/1	'14 DS	<i>3.0-liter Powertrain Diagnostic And System Enhancements</i> This bulletin applies to vehicles equipped with a 3.0-liter diesel engine (sales code EXF). Customers may experience an intermittent engine shudder or vibration which may not set a diagnostic trouble code. In addition, other customers may experience a malfunction indicator lamp illumination upon which the technician may find one or more of the following DTCs have been set: P20C2-00 - Reductant Heater 3 Control Circuit Performance P204F-00 - Reductant System Performance P20E9-00 - Reductant Pressure Too High P249C-00 - Excessive Time To Enter Closed Loop Reductant Injection Timing Control P1288-00 - NOX Sensor 1/2 Zero Offset Too High P2002-00 - Diesel Particulate Filter Regeneration Frequency P2299-00 - Brake Pedal Position/Accelerator Pedal Position Incompatible P241D-00 - SCR Inducement – Forced Engine Shutdown P016A-00 - Excessive Time To Enter Closed Loop Air/Fuel Ratio Control P2459-00 - Diesel Particulate Filter Regeneration Frequency P0133-00 - O2 Sensor 1/1 Slow Response P2084-00 - Exhaust Gas temperature Sensor Circuit Performance – (1/2) P0171-00 - Fuel System 1/1 Lean P0426-00 - Catalyst Temperature Sensor Circuit Performance (1/1) P0045-00 - Turbocharger Boost Control Circuit/Open P0087-00 - Fuel Rail Pressure Too Low P009A-00 - Intake Air Temperature/Ambient Air Temperature Correlation. P0128-00 - Thermostat Rationality P0234-00 - Turbocharger Overboost Condition P0420-00 - Catalyst Efficiency (Bank 1) P05F8-00 - Reductant Heater Control Module Performance P050E-00 - Cold Start Engine Exhaust Temperature Too Low P200A-00 - Intake Manifold Runner Performance – (Bank 1) P200B-00 - Intake Manifold Runner Performance – (Bank 2) P202E-00 - Reductant Injection Valve Circuit Performance P2080-00 - Exhaust Gas Temperature Sensor Circuit Performance P20BA-00 - Reductant Heater 1 Control Circuit Performance P20BE-00 - Reductant Injection Valve Circuit Performance P20C2-00 - Reductant Heater 3 Control Circuit Performance P225C-00 - NOX Sensor 1/1 Performance – Signal Stuck High P225C-00 - NOX Sensor 1/1 Performance – Signal Stuck Low P2453-00 - Diesel Particulate Filter Differential Pressure Sensor Circuit Performance P24C2-00 - Exhaust Gas Temperature Measurement System – Multiple Sensor Correlation (Bank1) P24F2-00 - EGR Temperature/Charge Air Cooler Temperature Correlation P2564-00 - Turbocharger Position Sensor Circuit Low P24C2-00 - Exhaust Gas Temperature Measurement System – Multiple Sensor Correlation (Bank1) P24F2-00 - EGR Temperature/Charge Air Cooler Temperature Correlation

Continued on next page...

CATEGORY 18**VEHICLE PERFORMANCE****TSB#****MODEL****SUBJECT/DESCRIPTION**

18-021-15
REV C
6/10/1
continued

P2564-00 - Turbocharger Position Sensor Circuit Low
P2565-00 - Turbocharger Position Sensor Circuit High
U029D-00 - Lost Communication With NOX Sensor Module "A"
U029E-00 - Lost Communication With NOX Sensor Module "B"

The following powertrain system improvements/enhancements are also included in this software release

- Enhancements to improve A/C compressor relay duty cycle operation to prevent ignition off battery draw.
- Powertrain system improvements to enable EGR cleaning routing.

This bulletin involves reprogramming the powertrain control module with the latest available software. It also involves replacement of the oxygen (O2) sensor and cleaning or replacement of the exhaust gas temperature (EGR) sensor, if necessary, depending on diagnostic trouble codes that may have set.

18-057-15 '13 DJ/D2
7/25/15

Flash: 6.7-liter Diagnostic and system Improvements

Several software improvements are available for the following conditions:

The following DTC has been changed from a two trip fault to one trip fault:

U1A24 - Lost Communication with Ammonia Sensor.

These faults have been changed from a one trip fault to a two trip fault:

U110E - Lost Ambient Temperature Message
P0201-P0206 - Fuel Injector X Circuit/Open
P049D - EGR Control Position Exceeding Learning Limit
P0711 - Transmission Temperature Sensor Performance
P0712 - Transmission Temperature Sensor Low
P0713 - Transmission Temperature Sensor High
P0714 - Transmission Temperature Sensor Intermittent
P0740 - TCC Out of Range
P0869 - Line Pressure High
P0933 - Hydraulic Pressure Sensor Range/Performance
P0934 - Line Pressure Sensor Circuit Low
P0935 - Line Pressure Sensor Circuit High
P1775 - Solenoid Switch Valve Latched in TCC Position
P1776 - Solenoid Switch Valve Latched in LR Position
U0100 - Lost Communication with ECM/PCM
U0002 - CAN C Bus Off Performance – Bus Off

CATEGORY 18**VEHICLE PERFORMANCE**

<u>TSB#</u>	<u>MODEL</u>	<u>SUBJECT/DESCRIPTION</u>
18-057-15 7/25/15	'13 DJ/D2	<p><i>Flash: 6.7-liter Diagnostic and system Improvements</i></p> <p>Several software improvements are available for the following conditions:</p> <p>The following DTC has been changed from a two trip fault to one trip fault: U1A24 - Lost Communication with Ammonia Sensor.</p> <p>These faults have been changed from a one trip fault to a two trip fault:</p> <p>U110E - Lost Ambient Temperature Message P0201-P0206 - Fuel Injector X Circuit/Open P049D - EGR Control Position Exceeding Learning Limit P0711 - Transmission Temperature Sensor Performance P0712 - Transmission Temperature Sensor Low P0713 - Transmission Temperature Sensor High P0714 - Transmission Temperature Sensor Intermittent P0740 - TCC Out of Range P0869 - Line Pressure High P0933 - Hydraulic Pressure Sensor Range/Performance P0934 - Line Pressure Sensor Circuit Low P0935 - Line Pressure Sensor Circuit High P1775 - Solenoid Switch Valve Latched in TCC Position P1776 - Solenoid Switch Valve Latched in LR Position U0100 - Lost Communication with ECM/PCM U0002 - CAN C Bus Off Performance – Bus Off U110E - Lost Ambient Temperature Message</p> <p>Improvements to prevent or reduce malfunction indicator lamp (MIL) illumination when no defect is present for:</p> <p>P2281 - Air Leak Between MAF and Throttle Body U3017 - Control Module Timer/Clock Performance P1477 - Dual Snorkle Calibration Change to Voltage Limit P20EE - SCR NOX Catalyst Efficiency Below Threshold – Bank 1 P20E8 - (Diesel Exhaust Fluid) Reductant Pressure Too Low U3017 - Control Module Timer/Clock Performance P026B - Injection Timing Performance P0128 - Thermostat Rationality. In cold ambient temperature. P0087 - Fuel Rail Pressure Too Low U1421 - Implausible ignition Key Off Time Received P026A - Charge Air Cooler efficiency Below Threshold P04DB - Crankcase Ventilation System Disconnected. P0544 - Exhaust Gas Temperature Sensor Circuit – Band1 Sensor 1 P0562 - Battery Voltage Low P0604 - Internal Control Module RAM Error P1451 - Diesel Particulate Filter System Performance P20EE - SCR NOX Catalyst Efficiency Below Threshold – Bank 1 P202E - Diesel Exhaust Fluid (DEF) Reductant Injector Performance P2201 - Aftertreatment NOX Sensor Circuit Performance – Bank 1 Sensor 1 P2281 - Air Leak Between MAF and Throttle Body P24A5 - EGR Cooler Bypass Bank 1 Control Stuck P2459 - Diesel Particulate Filter Regeneration Too Frequent P249E - Closed Loop SCR Reductant Injection Control At Limit – Flow Too High</p>

Continued on next page..

CATEGORY 18**VEHICLE PERFORMANCE****TSB#****MODEL****SUBJECT/DESCRIPTION**

18-057-15

7/25/15

continued

Other updates also included:

- Transmission Updates
- Alternator Dropout Threshold Set to 500RPM
- Warm Up Combustion Stability Improvement
- Urea Dosing During Stationary Regen
- Dual Snorkle Calibrate Mode
- Various Urea system calibration changes and cold weather system improvements and dosing heater thaw times
- Various additional WiTECH data and system test additions or improvements
- 68RFE Transmission shift quality improvements
- Cruise control system improvements
- System enhancements to starter lockout feature
- Erroneous "Service Exhaust System – see dealer" message setting with the ignition in the "Run" position, engine not running
- I/M OBD II readiness – DTC P2002 improvements help Particulate Matter (PM) filter monitor group to be set to ready more often
- Add engine run time to fuel filter minder
- Remove MIL for DTC; P1C70 – SCR Error Detected – Engine Disabled
- Frozen CAC Diagnostic Improvement
- WiTECH – Reset fix (PTO request on Pickup)
- WiTECH – Road governor speed upper limit adjustment
- ACR Performance test fix
- DEF Refill detection calibration change
- Grid heater inhibit correction
- P0544 – Exhaust Gas Temperature Sensor Circuit – Bank 1 Sensor 1 – Does not clear correctly
- Fuel filter minder distance trigger correction
- Fuel system test improvements
- Exhaust brake switch improvement
- Cold idle stability improvement
- Add ability to reset soot load after DPF replacement
- Correct condition – Cruise control does not cancel at key off.

The repair involves erasing and reprogramming the powertrain control module with the latest software revision.

CATEGORY 21**TRANSMISSION AND TRANSFER CASE**

<u>TSB#</u>	<u>MODEL</u>	<u>SUBJECT/DESCRIPTION</u>
21-012-14 REV B 9/26/14	'13-'15 DS	<p><i>8 Speed Transmission Shift Adaptation, Drive Learn Procedure</i></p> <p>This bulletin applies to vehicles equipped with the 8HP70 (sales code DFK) 8-speed automatic transmission. Customers may indicate that the transmission shift quality does not meet their expectations.</p> <p>The 8HP70 8-speed automatic transmission uses a sophisticated shift algorithm that includes learned information so that the shift quality remains excellent even as the transmission wears. This learned information is recorded. Each applied clutch records the amount of time it takes to fill the clutch (fast filling counter/filling time) and the amount of pressure (filling counter/filling pressure). This bulletin involves performing a transmission adaptation learn procedure based on a subjective shift quality rating evaluation.</p>
21-013-15 3/3/15	'13-'14 D2/DD/DP	<p><i>Flash: AS69RC Transmission Shift and Diagnostic Enhancements</i></p> <p>Customers may experience one or more of the following conditions.</p> <ul style="list-style-type: none">• Less than desired towing performance while using cruise control.• Harsh engagement while shifting from neutral to drive, neutral to reverse, or park to reverse with vehicle still in motion (rolling garage shift).• Transmission Oil Temperature light illumination during high engine and tow loads.• Engine flare during 2-1 tip in downshift.• Less than desired shift quality during 6-5, 5-4 coasting downshifts.• Delayed downshifts in Tow/Haul mode while driving down grades.• Less than desired transmission shift performance when transitioning from low traction surface to high traction surfaces (i.e. ice covered road to clear pavement).• Harsh 2-1 downshift.• Less than desired shift points during light pedal and Wide Open Throttle (WOT)• Delayed engagement when shifting from neutral to drive, neutral to reverse, or park to reverse (garage shifts).• Audible squawk noise on 4-3 downshift.• Poor vehicle acceleration in first gear with vehicle fully loaded.• Malfunction Indicator Lamp (MIL) illumination with no defect found for Diagnostic Trouble Code (DTC) Ps53 – PTO Sense Circuit High. <p>The repair procedure involves reflashing the transmission control module with the latest software calibration.</p>

CATEGORY 25**EMISSIONS CONTROL**

TSB#	MODEL	SUBJECT/DESCRIPTION
25-003-14 9/6/14	'13-'15 DJ/D2/DD/DP	<p><i>Information: P207F P1c70 and SCR Inducement Strategy</i></p> <p>A vehicle may come in with a malfunction indicator lamp (MIL) illuminated. Upon inspection, the technician may find the following diagnostic trouble codes (DTCs) set in the powertrain control module (PCM).</p> <p>P207F – Reductant Quality Performance P1C70 – SCR Error Detected – Engine Disabled</p> <p>These codes are set when the system detects inadequate DEF quality due to diluted, degraded, or contaminated fluid. As a result, the system will enter what is commonly called “Inducement Strategy.” This is indicated by a message “5 MPH Max Speed in XXX miles, Service DEF System, See Dealer” which will incrementally count down. Once the mileage countdown has expired, the EVIC will display “5MPH Max Speed on Restart, Long Idle, or Refuel, Service DEF See Dealer” followed by “5 MPH Max Speed, Service DEF System, See Dealer.”</p> <p>In order to repair the vehicle, normal diagnostics should be performed for the DTC P207F and the root cause of the inadequate DEF quality corrected per published service information. However, once repaired and the codes have been cleared, the technician may find that DTC P1C70 will remain set and the EVIC message still displayed. To properly clear out the inducement message and reset the system, the PCM should be flashed, using WiTECH, with the current most up to date calibration.</p>

25-005-14 9/19/14	'13-'14 D2/DJ '11-'14 DD/DP	<p><i>Diesel Exhaust Fluid</i></p> <p>This information-only bulletin provides information regarding the diesel exhaust fluid (DEF) vehicle new-in-service delivery fill guidelines.</p> <p>Do not prematurely fill the DEF tank. DEF has a limited shelf life based on ambient temperatures and exposure to sunlight. Vehicles that are exposed to high temperatures for lengths of time may have their DEF urea concentration degrade to the point that the DEF will become less effective at reducing NOx levels in the SCR catalyst. If this occurs, the engine control system may illuminate the malfunction indicator lamp (MIL) and set related diagnostic trouble codes (DTC).</p> <p>The following chart provides the approximate shelf life of DEF versus temperature.</p>
----------------------	--------------------------------	---

50°F	36 MONTHS
77°F	18 MONTHS
86°F	12 MONTHS
95°F	6 MONTHS
104°F	2 MONTHS

Further notes about DEF and Ram trucks:

The DEF tank has been designed with an air space that accommodates the expansion of DEF. Never “top-off” the DEF tank after a normal fill, as that will allow DEF to fill the expansion space, which can cause damage to the tank.

DEF is subject to freezing at the lowest temperatures. For example, DEF may freeze at temperatures at or below 12°F. The system has been designed to operate in this environment.

Containers, pumps or plumbing containing iron, non-stainless steel, aluminum or brass will rapidly corrode if used to store or transfer DEF. This corrosion can result in plugging of the onboard DEF filter, or other emission system damage.

DEF can crystallize when exposed to air. However, the crystals should re-dissolve when reintroduced to fresh DEF. Crystallization may be noticed around the DEF filler opening and is normal.

2015 RECALL NOTICES

SAFETY RECALL N49/NHTSA 13V-529 LEFT OUTER TIE ROD ASSEMBLY

Date: January 2014

Models/Production:

'08 (DH) 1500 series 4x4 Mega Cab
'08-'09 (DH) 2500/3500 series 4x4
'08-'09 (D1) 3500 series 4x4
'10-'12 (D2) 3500 series 4x4
'10-'12 (DJ) 2500 series 4x4
'08-'10 (DC) 3500 Cab Chassis
'11-'12 (DD) 3500 Cab Chassis

This recall applies only to the above vehicles built between February 14, 2008, and December 22, 2012.

Subject: The left tie rod ball stud on about 264,000 of the above vehicles may fracture under certain driving conditions. This could cause a loss of directional control and/or a crash without warning.

Repair: The steering linkage assembly must be inspected and replaced if required.

CUSTOMER SATISFACTION NOTIFICATION P26 REPROGRAM ANTILOCK BRAKE SYSTEM MODULE

Date: November 2014

Models/Production:

'13-'14 (DS) 3500 series
'13-'14 (DD) 3500 series
'13-'14 (DJ) 2500 series
'13-'14 (DP) 4500/5500 series

This notification applies only to the above vehicles built from June 25, 2012, through April 23, 2014.

Subject: The antilock brake system (ABS) module on about 176,500 of the above vehicles may contain software that causes an intermittent loss of the speedometer, electronic stability control (SC) and/or antilock brake system (ABS).

Repair: The ABS module must be reprogrammed with new software.

EMISSIONS RECALL P35 DIESEL PARTICULATE FILTER WIRING

Date: January 2015

Models/Production:

'13 (DJ) 2500 series
'13 (D2) 3500 series

Subject: The diesel particulate filter (DPF) temperature sensor electrical connectors on about 28,000 of the above vehicles may have been connected to the incorrect body wiring harness electrical connectors. This can cause tailpipe emissions of oxides of nitrogen (NOx) to exceed the Federal and California emissions standard.

Repair: The DPF temperature sensor electrical connectors must be connected to the correct body wire harness connectors.

SAFETY RECAL P65/NHTSA 14V-635 DIESEL FUEL HEATER ELECTRICAL CONNECTOR

Date: June 2015

Models/Production:

'10 (DC) 3500 Cab Chassis
'10 (DM) 4500/5500 Cab Chassis
'10-'14 (DJ) 2500 Pickup Truck
'10-'14 (D2) 3500 Pickup Truck
'11-'14 (DD) 3500 Cab Chassis
'11-'14 (DP) 4500/5500 Cab Chassis

This recall applies only to the above vehicles built through 9/5/13.

Subject: The diesel fuel heater electrical connector on about 314,000 of the above vehicles may overheat and cause a fuel leak. The diesel fuel heater housing at the fuel heater electrical connector may overheat, leading to the failure of the O-rings that seal the male electrical terminals in the diesel fuel filter/heater assembly. A leaking diesel fuel filter/heater could cause underhood smoke and/or an engine compartment fire.

Repair: The diesel fuel filter/heater and wire harness electrical connector on 2010 models must be inspected and replaced if required. The diesel fuel heater wire harness electrical connector must be replaced on all 2011 through 2014 model year vehicles and the diesel fuel filter/heater housing must be inspected for fuel leaks. If a fuel leak is found, the diesel fuel filter/heater assembly must be replaced.

EMISSIONS RECALL R04 EXHAUST HIGH FREQUENCY DECOUPLER

Date: June 2015

Models/Production: '14-'15 DS 1500 series 4x2 truck

This recall applies only to the above vehicles built through 12/22/14.

Subject: The exhaust high frequency decoupler (HFD) on about 2,400 of the above vehicles, located between the turbocharger and the diesel particulate filter/converter assembly, may fracture due to fatigue and cause an exhaust leak.

Repair: The exhaust down pipe with the high frequency decoupler must be replaced.

SAFETY RECALL R40/NHTSA 15V-461 RADIO SECURITY VULNERABILITY

Date: July 2015

Models/Production: '13-'15 DS/DD/DJ/DP/D2 pickups

This recall applies only to the above vehicles equipped with a Uconnect 8.4" screen radio (sales code RA3 or RA4) built through 7/23/15.

Subject: The radios on about 1,410,000 of the above vehicles have certain software security vulnerabilities which could allow unauthorized third-party access to some networked vehicle control system. Exploitation of the software security vulnerabilities could lead to exposing the driver, the vehicle occupants or any other individual or vehicle with proximity to the affected vehicle to a potential risk of injury.

Repair: The radio software must be updated to remove the security vulnerability condition.

DID YOU KNOW?

Did you know that I am determined to get you to try a TechAuthority subscription?

Earlier in this column I have presented both the "pro" and the "con" arguments. In this final segment I will give you several more reasons that, should you need the TechAuthority resource, you'll feel good about the \$35 investment for the three-day access.

Here are some examples:

For the Third Generation, 2003-2004 owner: There is TSB 03-003-04; Subject – Launch shudder. The bulletin tells the dealer/owner how to adjust the working angle of the propeller shaft.

Third Generation, '03-'07 owner: There is TSB 22-005-06; Subject – Front end shimmy on 4x4 vehicles. The bulletin discusses proper tire pressure, replacement of tie rod ends and the replacement of a steering damper.

Third Generation, '03-'05 owner: There is TSB 18-022-07; Subject – 5.9 Diesel engine enhancements. The bulletin discusses a flash to the engine control module to address cooling system problems (temperatures for fan engagement) and water-in-fuel concerns.

Third/Fourth Generation, '03-'09 owner: There is TSB 14-001-10; Subject – New fuel control actuator (FCA) released to the service network. The bulletin discusses a part number supersession to correct DTC P0251.

I only make mention of these bulletins to reemphasize the huge amount of data that TechAuthority can provide you based on your truck's VIN. As mentioned, these oldies do not show up in this issue's calendar-year-only review, but are there for your review should you do a search using your VIN.

Also, as mentioned, you can click on to the factory service manual and, should you have the time and patience, download and print the entire book.

**Robert Patton
TDR Staff**

Postscript – Unusual Billing Address

As credit card charges cycle through, I received my September billing statement. Checking the line items, I wondered "What the heck is 'SOI* SBS KENOSHA 800-892-9650 WI' for \$35?"

Research on the internet didn't instantly reveal anything to trigger my memory of the TechAuthority purchase. To no avail, I called the 800# that was given only to hear a recorded message about "VW/Audi Tools and Equipment."

Later one of the internet research clues mentioned that SOI* SBS did billing for VW Service books. That's when it hit me, TechAuthority has a funky, third-party billing system.

Did I mention that TechAuthority was difficult to use?

**Robert Patton
TDR Staff**

TECHNICAL SERVICE BULLETINS ISSUED DURING 2016

CATEGORY 8 ELECTRICAL

<u>TSB#</u>	<u>MODEL</u>	<u>SUBJECT/DESCRIPTION</u>
08-0444-16 4/20/16	'16 DS/DJ/ D2/DD/DP	<p><i>Radio Frequency Hub Module (RFHM) Enhancement—Flash Update</i></p> <p>This bulletin applies to vehicles built on or before April 6, 2016 and equipped with one of the following sales codes:</p> <ul style="list-style-type: none"> • (GXD) Remote Proximity Keyless Entry. • (GXM) Remote Keyless Entry With All Secure. • (GX4) Keyless Go. <p>Customers may describe the instrument cluster is illuminating by itself after the ignition has been off for an extended period of time (10 minutes or more).</p> <p>The repair procedure involves a flash update to the radio frequency hub module software.</p>
08-046-16 4/22/16	'14-'16 D2/DJ	<p><i>Air Suspension Control Module (ASCM) System Enhancements—Flash Update</i></p> <p>This bulletin applies to vehicles built on or before April 10, 2016 equipped with Cummins Diesel Engine and Auto Level Rear Air Suspension (sales code SEB).</p> <ul style="list-style-type: none"> • A customer may describe the following: • Cluster stays awake after ignition is turned off for 10 minutes or more. <p>False message “Battery Voltage Low – Start Engine to Change Ride Height” which appears in the Electronic Vehicle Information Center (EVIC). This condition may happen when the vehicle is first started and trying to move the suspension from trailer ride height to normal ride height.</p> <p>The repair procedure involves an update to the ASCM software.</p>
08-050-16 4/22/16	'16 DJ/D2/DD/DP	<p><i>Headlamps May Be Out Of Adjustment Or Alignment.</i></p> <p>This bulletin applies to vehicles built on or before March 14, 2016 without Auto Level Rear Air Suspension (sales codes SEB).</p> <p>The customer may describe that the headlamps are out of alignment or oncoming vehicles are flashing their bright lights at them.</p> <p>This bulletin involves adjusting the headlamps to specified alignment.</p>
08-051-16 4/23/16	'15-'16 DS	<p><i>Air Suspension Control Module (ASCM)—Flash Update</i></p> <p>This bulletin applies to vehicles built on or after December 4, 2014 and on or before February 22, 2016 equipped with Air Suspension, 4-Corner (sales code SER).</p> <p>Customers may experience no ride height change with the vehicle in really cold conditions and in addition they may also have a Malfunction Indicator Lamp (MIL) illumination. Upon further investigation the technician may find that several Diagnostic Trouble Codes have been set.</p> <p>In addition, the customer may notice that the vehicle does not change ride heights when selected in cold weather.</p> <p>The repair procedure involves a flash update to the air suspension control module.</p>
08-053-16 REV B 5/19/16	'15 DS/DJ/ D2/DD/DP	<p><i>RA3/RA4 Radio Software Enhancements—Flash Update</i></p> <p>This bulletin applies to vehicles equipped with one of the following radios:</p> <ul style="list-style-type: none"> • UConnect 8.4A (sales code RA3). • UConnect 8.4AN (sales code RA4). <p>The customer may experience one or more of a lengthy list of problems.</p> <p>The repair procedure involves a software update to the radio. This software update is only compatible with the 2015 model year vehicles listed above. Attempting to flash a 2013-2014 model year vehicle with this software will result in a loss of some radio/navigation functions. Should this occur, reinstalling the correct software for the radio will correct the condition.</p>

CATEGORY 8**ELECTRICAL**

<u>TSB#</u>	<u>MODEL</u>	<u>SUBJECT/DESCRIPTION</u>
08-054-16 4/29/16	'13-'14 DS/DD/ DJ/DP/D2	<p><i>RA3 RA4 Radio Enhancements—Flash Update</i> This bulletin applies to vehicles equipped with one of the following radios:</p> <ul style="list-style-type: none"> • UConnect 8.4A (sales code RA3) • UConnect 8.4AN (sales code RA4) <p>A customer may experience one or more of a lengthy list of problems.</p> <p>The repair procedure involves inspecting and updating the radio software.</p>
08-057-16 5/3/16	'16 DS/DJ/ DD/DP/D2	<p><i>RA3 RA RA4 Radio Enhancements—Flash Update</i> This bulletin applies to vehicles built on or before April 2, 2016 equipped with UConnect 8.4 (sales code RA3) or UConnect 8.4AN (sales code RA4).</p> <p>This bulletin involves inspecting and, if required, updating the radio software.</p>
08-072-16 7/8/16	'15 DS/DJ/D2	<p><i>RG3, RG4, RJ3, RJ4 Radio Enhancements—Flash Update</i> This bulletin applies to vehicles built on or before July 21, 2015 and equipped with one of the following radios:</p> <ul style="list-style-type: none"> • UConnect 8.4 (sales code RG3) • UConnect 8.4 AN (sales code RG4) • UConnect 8.4 (sales code RJ3) • UConnect 8.4N (sales code RJ4) <p>Customers may experience one or more of a listing of various problems.</p> <p>The repair procedure involves updating the radio software.</p>

CATEGORY 9**ENGINE**

<u>TSB#</u>	<u>MODEL</u>	<u>SUBJECT/DESCRIPTION</u>
09-006-15 REV A 11/13/15	'14 DS	<p><i>Intermittent Engine Shudder While Driving</i> This bulletin applies to vehicles equipped with the 3.0-liter V6 Turbo Diesel engine.</p> <p>Customers may experience a slight engine shudder while driving. They may state that the condition feels and sounds like driving over rumble strips. It may also be perceived as an internal transmission issue or engine misfire. No Diagnostic Trouble Codes (DTCs) will set as a result of this condition.</p> <p>The root cause of the engine shudder has been found to be due to excess carbon build-up on the exhaust valve stems and will typically happen on vehicles driven mostly in light load conditions. As a result, new cylinder heads have been released that are equipped with newly designed valve stem seals. These newly designed seals are designed to help prevent excessive carbon from building up on the valve stems.</p> <p>Although it may be hard to reproduce, engine shudder resulting from these excess carbon deposits, will typically only happen under the following driving conditions:</p> <ul style="list-style-type: none"> • Steady speeds between 50 and 70mph • Engine speed between 1600-2000rpm • Present during engine warm up to operating temperature after a cold soak. • Only present for a few seconds at a time and often during a 6-7 upshift. • Light load acceleration or while driving up a slight grade. • Symptoms will go away either by aggressively applying the accelerator pedal or going into a zero throttle deceleration. <p>The repair involves replacing the engine cylinder heads.</p>

<u>TSB#</u>	<u>MODEL</u>	<u>SUBJECT/DESCRIPTION</u>
18-015-15 2/28/15	'14-'15 DS	<p><i>Malfunction Indicator Lamp (MIL) Illumination And/Or Intermittent No Crank/No Start</i></p> <p>This bulletin applies to vehicles equipped with a 3.0-liter diesel engine and engine block heater. Customers may experience a MIL illumination when ambient temperatures fall below 32°F. Upon further inspection, a technician may find the following Diagnostic Trouble Codes (DTCs).</p> <ul style="list-style-type: none"> • P0299 – Turbocharger Underboost Condition • U1424 – Implausible Engine Torque Signal Received <p>In addition, a customer vehicle may come in with a no crank/no start. This may have occurred after the vehicle has been driven for an extended period of time in extremely low ambient and then allowed to sit overnight. Further diagnosis may indicate a possible inoperative starter.</p> <p>A possible cause of these concerns may be attributed to internal icing of the Charge Air Cooler (CAC) system and intake manifold. Icing will occur because warm, moist air from the turbocharger is being rapidly cooled and the moisture is then condensed into liquid by the CAC. The liquid is then distributed into the rest of the intake system, which is operating at ambient temperature, where it will then freeze.</p> <p>Vehicles that are driven for extended periods of time are susceptible to higher amounts of ice buildup within the intake manifold. Once the vehicle is turned off and allowed to sit, the ice formation in the intake will begin to melt due to the elevated underhood temperatures. The moisture will then run down the intake runners and accumulate in the combustion chamber through an open intake valve, causing the engine to hydro-lock.</p> <p>To help prevent icing in the CAC system when the vehicle is operated in low ambient temperatures, it is highly recommended that the vehicle have winter front cover installed. This raises the CAC outlet temperatures above freezing which will help reduce condensation build up.</p> <p>This bulletin involves inspecting the Charge Air Cooler (CAC) system for excessive water and/or ice and drying the CAC components if needed. It also involves installing a winter front cover.</p>
18-064-15 9/24/15	'14 DS	<p><i>P20EE SCR NOX Catalyst Efficiency Below Threshold Bank 1</i></p> <p>This bulletin applies to vehicle equipped with a 3.0-liter Diesel Engine.</p> <p>Customers may experience a Malfunction Indicator Lamp (MIL) illumination. Upon further investigation, the technician may find Diagnostic Trouble Code (DTC) P20EE SCR NOX Catalyst Efficiency Below Threshold Bank 1 set in the Powertrain Control Module (PCM) memory.</p> <p>The proper repair procedure involves replacing the Selective Catalyst Reduction (SCR) Catalyst assembly.</p> <p><i>Editor's note: A new category, "Vehicle Performance," and a new series of pages. I counted the bulletins and there are 15, of which 9 are flash updates to the powertrain or engine control module. Geez.</i></p>

CATEGORY 18**VEHICLE PERFORMANCE****TSB#****MODEL****SUBJECT/DESCRIPTION**18-017-16
2/17/16

'14 DS

3.0-Liter Powertrain Diagnostic And System Enhancements—Flash Update
This bulletin applies to vehicles equipped with a 3.0-liter Diesel Engine.

Customers may experience an intermittent engine shudder, bucking under hard acceleration, or vibration. In addition other customers may experience a Malfunction Indicator Lamp (MIL) illumination upon which the technician may find one or more of the following DTCs have been set:

P1296	P249C	P20C2	P24A4	P24D1	P1288	P1289
P2463	U0422	U3017	P26AB	P24AF	P2196	P1E0C
P2237	P1297	P0420	P204F	P20E9	P2002	P2299
P241D	P016A	P2459	P0133	P2084	P0171	P0426
P0045	P0087	P009A	P0128	P0234	P05F8	P050E
P200A	P200B	P202E	P2080	P20BA	P20BE	P225C
P225D	P2453	P24C2	P24F2	P2564	P2565	U029D
U029E						

Upon further investigation a technician may find the following Diagnostic Trouble Code (DTC) set in the TCM memory:

U1424-00

The following enhancements are also included in this software update:

- Enhancements to improve A/C compressor relay duty cycle operation to prevent ignition off battery draw.
- Powertrain system improvements to enable EGR cleaning routine.
- DTC P0171-00 System Too Lean (Bank 1) has now changed to P026C-00 Fuel Injection Quantity Lower Than Expected.
- DTC P0172-00 System Too Rich (Bank 1) has now changed to P026D-00 fuel Injection Quantity Higher Than Expected.

This bulletin involves reprogramming the Powertrain Control Module (PCM) with the latest available software. It also involves replacement of the Oxygen (O2) Sensor and cleaning or replacement of the Exhaust Gas Temperature (EGT) Sensor if necessary depending on Diagnostic Trouble Codes (DTCs) that may have set.

18-018-16
2/17/16

'15 DS

3.0-Liter Powertrain Diagnostic and System Enhancements—Flash Update
This bulletin applies to vehicles equipped with a 3.0-liter Diesel Engine.

Customers may experience bucking under hard acceleration. In addition, other customers may experience a Malfunction Indicator Lamp (MIL) illumination. Upon further investigation a technician may find one or more of the following Diagnostic Trouble Codes (DTCs) set in the PCM memory.

P1296	P249C	P20C2	P24A4	P24D1	P1288	P1289
P2463	U0422	U3017	P2196	P1E0C	P2237	P1297
P0420	P24AF	P26AB	P204F	P20E9	P2002	P2299
P208B	P016A					

Upon further investigation a technician may find the following Diagnostic Trouble Code (DTC) set in the TCM memory:

U1424-00

The following enhancements are also included in this software update:

- Enhancements to improve A/C compressor relay duty cycle operation to prevent ignition off battery draw.
- Powertrain system improvements to enable EGR cleaning routine.
- DTC P0171-00 System Too Lean (Bank 1) has now changed to P026C-00 Fuel Injection Quantity Lower Than Expected.
- DTC P0172-00 System Too Rich (Bank 1) has now changed to P026D-00 fuel Injection Quantity Higher Than Expected.

This bulletin involves reprogramming the Powertrain Control Module (PCM) with the latest available software.

TSB#	MODEL	SUBJECT/DESCRIPTION																												
18-022-16 3/4/16	'13 DD/DP	<p><i>6.7-Liter Diagnostic And System Improvements—Flash Update</i></p> <p>This bulletin applies to vehicles equipped with a 6.7-liter Cummins engine. Several software improvements are available for the engine. These improvements are separated into categories</p> <p>These DTCs have been changed from a one trip fault to a two trip fault:</p> <p style="padding-left: 40px;">P0201-P0206 – Fuel Injector X Circuit/Open P049D – EGR Control Position Exceeded Learning Limit</p> <p>This DTC has been changed from a two trip fault to a one trip fault:</p> <p style="padding-left: 40px;">U12A4 – Lost Communication With Ammonia Sensor</p> <p>Improvements to prevent or reduce unnecessary Malfunction Indicator Lamp (MIL) illumination for:</p> <table style="margin-left: 40px; border-collapse: collapse;"> <tr> <td>P1C55</td> <td>P205E</td> <td>U110E</td> <td>P20E8</td> <td>P2281</td> <td>U3017</td> <td>U1421</td> </tr> <tr> <td>P0128</td> <td>P0087</td> <td>P0544</td> <td>P2002</td> <td>P061A</td> <td>P0234</td> <td>P026A</td> </tr> <tr> <td>P0299</td> <td>P0544</td> <td>P0562</td> <td>P20EE</td> <td>P2201</td> <td>P24A5</td> <td>P2459</td> </tr> <tr> <td>P249E</td> <td></td> <td></td> <td></td> <td></td> <td></td> <td></td> </tr> </table> <p>Other updates:</p> <ul style="list-style-type: none"> • SCR Efficiency scan tool test improvement. • Various Urea system calibration changes, cold weather system improvements and dosing heater thaw times. • Various additional wiTECH data and system test additions or improvements. • Cruise control system improvements. • System enhancements to starter lockout feature. • Fuel Filter Minder system calibration enhancements. • Exhaust brake switch operation improvements. • Charging system improvements for dual alternator applications. • Erroneous “Service Exhaust System – see dealer” message setting with the ignition in the “Run” position, engine not running. • Remove MIL for DTC; P1C70 – SCR Error Detected – Engine Disabled. • Wait To Start (WTS) bulb check timing improvements (1 second). • Set PTO maximum speed to 2,000rpm. • Allow Mobile PTO operation in neutral. • Frozen CAC Diagnostic Improvement. • WiTECH – Reset fix (PTO request on Pickup). • WiTECH – Road Governor Speed Upper Limit adjustment • SCR Performance Test Fix. <p>There will be a choice between two calibrations. One for a 3-sensor configuration that utilizes an ammonia sensor and one for 2-sensor configuration for vehicles that have had the ammonia sensor removed. Be sure to select the correct software based on the configuration.</p> <p>This bulletin involves selectively erasing and reprogramming the Engine Control Module (ECM) with new software.</p>	P1C55	P205E	U110E	P20E8	P2281	U3017	U1421	P0128	P0087	P0544	P2002	P061A	P0234	P026A	P0299	P0544	P0562	P20EE	P2201	P24A5	P2459	P249E						
P1C55	P205E	U110E	P20E8	P2281	U3017	U1421																								
P0128	P0087	P0544	P2002	P061A	P0234	P026A																								
P0299	P0544	P0562	P20EE	P2201	P24A5	P2459																								
P249E																														

<u>TSB#</u>	<u>MODEL</u>	<u>SUBJECT/DESCRIPTION</u>
18-027-16 REV C 6/2/16	'16 DJ/D2	<p><i>6.7-Liter Diagnostic And System Improvements—Flash Update</i></p> <p>This bulletin applies to vehicles built on or before April 7, 2016 equipped with a 6.7-liter Cummins Diesel engine.</p> <p>The following Diagnostic Trouble Codes (DTCs) have been changed from a one trip fault to a two trip fault:</p> <ul style="list-style-type: none">P0421 – Catalyst 1 Efficiency Below Threshold Bank 1P2280 – Air Flow Restriction/Leak Between Air Cleaner and MAFP203C – (Diesel Exhaust Fluid) Reductant Level Sensor Circuit LowP208D – (Diesel Exhaust Fluid) Reductant pump Control Circuit High <p>Customers may experience a Malfunction Indicator Lamp (MIL) illumination. Upon further investigation a technician may find the following DTCs set in the PCM memory.</p> <ul style="list-style-type: none">P0128 – Thermostat Rationality ImprovementsP2281 – Air Leak Between MAF and Throttle BodyP218F – Reductant No Flow DetectedP0218 – Transmission High Temperature Operation Activated (68RFE Only)P0868 – Line Pressure Low, MIL Action (68RFE Only)U110E – Lost Ambient Temperature MessageP205E – (Diesel Exhaust Fluid) Reductant Tank Temperature Sensor Circuit Intermittent <p>In addition to addressing the above DTCs, the following powertrain system improvements/enhancements are also included in this software release:</p> <ul style="list-style-type: none">• Engine Noise Improvements.• Engine Hesitation Improvement.• Improved Engine Fuel Economy.• Reduction in engine noise during regeneration at idle.• 68RFE Transmission Overall Shift Quality Improvements.• Test results fix for partial range misfire (68RFE Only).• Ambient Air Temperature Improvements.• Stationary Desoot with wiTECH Fix.• OBD Misfire Monitoring Improvement (68RFE Only). <p>This bulletin involves reprogramming the Engine Control Module/Powertrain Control Module (ECM/PCM) with the latest available software.</p>

CATEGORY 18**VEHICLE PERFORMANCE****TSB#****MODEL****SUBJECT/DESCRIPTION**18-028-16 '14 DD/DP
3/19/16***6.7-Liter Diagnostic And System Improvements—Flash Update***

This bulletin applies to vehicles built equipped with a 6.7-liter Cummins Diesel engine.

Several software improvements are available for vehicles equipped with a Cummins Turbo Diesel. Improvements to prevent or reduce Malfunction Indicator Lamp (MIL) illumination when no defect is present for:

P1C55	P205E	P20E8	U110E	U3017	P0087	P0544
P2281	P0128	U1421	P202E	P20EE	P2002	P0604

These faults have been changed from a one trip fault to a two trip fault:

P0201-P0206 P049D

Other updates:

- Selective Catalytic Reduction (SCR) efficiency scan tool test improvement.
- Urea system calibration changes.
- Fuel filter minder calibration changes.
- Cruise control system improvements.
- Improvements in exhaust brake switch operation.
- Charging system improvements for dual alternator applications.
- Various wiTECH data and system test additions and improvements.
- OBD template changed for P2453.
- Dual fuel tank component update.
- Inducement timer reset (Feature enable in wiTECH).
- PTO denied status message update.
- PTO horn request sent to Body Control Unit (BCU).
- Wait To Start (WTS) bulb check timing improvements (1 second).
- Frozen Charge Air Cooler (CAC) diagnostic improvement.

There will be a choice between 2 calibrations. One for vehicles that utilize an ammonia sensor and one for vehicles that have had the ammonia sensor removed. Be sure to select the correct software based on vehicle configuration.

This bulletin involves selectively erasing and reprogramming the Engine Control Module (ECM) with new software.

18-036-16 '15 DD/DP
4/1/16***6.7-Liter Diagnostic And System Improvements—Flash Update***

This bulletin applies to vehicles built equipped with a 6.7-liter Cummins diesel engine. Several software improvements are available for vehicles equipped with a Cummins Turbo Diesel.

Improvements to prevent or reduce Malfunction Indicator Lamp (MIL) illumination when no defect is present for the following Diagnostic Trouble Codes (DTCs):

P1C55	P218F	P242F	U110E	P205E	P20E8	U3017
U1421	P2281					

Other software improvements:

- Ambient Air Temperature improvements.
- Operational Improvement for Dual Alternators.
- SCR Efficiency scan tool test improvement.
- Fuel Filter Minder calibration changes.
- WiTECH Fuel Pressure Override and Fuel System Run Up test improvements.
- EGR system improvement to help prevent freeze up.
- Diesel Exhaust Fluid (DEF) system enhancement during stationary regeneration.

This bulletin involves reprogramming the Engine Control Module (ECM) with the latest available software.

CATEGORY 18**VEHICLE PERFORMANCE****TSB#****MODEL****SUBJECT/DESCRIPTION**

18-037-16
REV A
4/23/16

'15 DJ/D2

6.7-Liter Diagnostic And System Improvements—Flash Update

This bulletin applies to vehicles equipped with a 6.7-liter Cummins Diesel engine.

Customers may experience a Malfunction Indicator Lamp (MIL) illumination. Upon further investigation a technician may find one or more of the following Diagnostic Trouble Codes (DTCs) set in the PCM memory:

P218F	P242F	P205E	U110E	P20E8	P2281	P1477
U1421	P026B					

In addition to addressing the above DTCs, the following powertrain system improvements/enhancements are also included in this software release:

- NOx sensor calibration improvements (sales code DG7).
- Enhanced software for a No crank/No start issue – U0100 (sales code DG7).
- Ambient Air Temperature (AAT) improvements.
- 68RFE Transmission overall shift quality improvements.
- SCR Efficiency scan tool test improvement.
- Charging system improvements for single alternator applications (changes the cutout threshold from 600 to 500rpm).
- Diesel Exhaust Fluid (DEF) system calibration improvement during Stationary Regeneration.
- Cold idle speed stability improvement.
- Charging system improvements for dual alternator applications.
- Torque increase to 865 ft-lbs (D2 vehicles with the Aisin transmission sales code DF2 only).
- Fuel Filter Minder calibration changes.
- WiTECH Fuel Pressure Override and Fuel System Run Up test improvements.

This bulletin involves reprogramming the Engine Control Module/Powertrain Control Module (ECM/PCM) with the latest available software.

18-038-16
4/1/16

'13-'15 DD/DP

P20EE SCR NOX Catalyst Efficiency Below Threshold Bank 1

This bulletin applies to vehicles equipped with a 6.7-liter diesel engine.

Customers may experience a Malfunction Indicator Lamp (MIL) illumination. Upon further investigation the technician may find Diagnostic Trouble Code (DTC) P20EE SCR NOX Catalyst Efficiency Below Threshold Bank 1 set in the Powertrain Control Module (PCM) memory.

This bulletin involve verifying the proper operation of the Diesel Exhaust Fluid (DEF) system and, if necessary, replacing the Selective Catalyst Reduction (SCR) Catalyst assembly.

18-039-16
4/2/16

'16 DD/DP

6.7-Liter Diagnostic And System Improvements—Flash Update

This bulletin applies to vehicles built on or before January 1, 2016.

These DTCs have been changed from a one trip fault to a two trip fault:

P2280 – Air Flow Restriction/Leak Between Air Cleaner and MAF
P203C – (Diesel Exhaust Fluid) Reductant Level Sensor Circuit Low
P208D – (Diesel Exhaust Fluid) Reductant Pump Control Circuit High

Customers may experience a Malfunction Indicator Lamp (MIL) illumination. Upon further investigation a technician may find the following Diagnostic Trouble Codes (DTCs) set in the PCM memory:

P1C55	P207F	P218F	U110E
-------	-------	-------	-------

In addition to addressing the above DTCs, the following powertrain system improvements/enhancements are also included in this software release.

- Ambient Air Temperature Improvements.
- Stationary de-soot with wiTECH fix.

This bulletin involves reprogramming the Engine Control Module/Powertrain Control Module (ECM/PCM) with the latest available software.

TSB#

MODEL

SUBJECT/DESCRIPTION

18-054-16 '14 DJ/D2
5/7/16

6.7-Liter Diagnostic and System Improvements—Flash Update

This bulletin applies to vehicles equipped with a 6.7-liter Cummins Engine.

Customers may experience a Malfunction Indicator Lamp (MIL) illumination. Upon further investigation a technician may find one or more of the following Diagnostic Trouble Codes (DTCs) set in the PCM memory:

P218F	P242F	P2281	P205E	U110E	P20E8	P1477
U3017	P0087	P0544	P0128	P214D	P24A5	P040B
U1421	P0420	P026B	P04DB	P1C55	P202E	P20EE
P2002	P0604	P1451				

In addition to the above symptoms, the following software improvements are also included in this update.

The following DTCs have been changed from a one trip fault to a two trip fault:

- P0201-P0206 – Fuel Injector X Circuit Open Fault Codes
- P049D – EGR Control Position Exceeding Learning Limit.
- P226C – Turbocharger Boost Control “A” Slow Response.

The following DTC has been changed from a two trip fault to one trip fault:

- U1A24 – Lost Communication With Ammonia Sensor

Other software enhancements included:

- NOx sensor calibration improvements.
- Cap Urea Dosing at Low Temps.
- Ambient Air Temperature (AAT) improvements.
- SCR efficiency scan tool test improvement.
- 68RFE transmission shift quality improvements for low speed first to neutral and neutral to first (garage shifts).
- Charging system improvements for single alternator applications (changes the cutout threshold from 600 to 500rpm).
- Diesel Exhaust Fluid (DEF) system calibration improvement during stationary regeneration.
- Cold idle speed stability improvement.
- Fuel Filter Minder calibration improvement to save current mileage count during module reflash.
- Diagnostic improvement for DTC P20E8 – (Diesel Exhaust Fluid) Reductant Pressure Too Low. Increases pump prime attempts to eliminate false failures.
- Cruise control system improvements.
- Improvements in exhaust brake switch operation.
- Charging system improvements for dual alternator applications.
- Cold Idle Stability improvements.
- Charge Air Cooler (CAC) leak detection software improvements.
- Various wiTECH data and system test additions or improvements.
- 68RFE transmission shift quality improvements.
- Dosing thaw calibration improvement.
- IM OBD II readiness – DTC P2002 improvements help Particulate Matter (PM) filter monitor group to be set to ready more often.
- Grid heater inhibit operation correction.
- Add engine run time to fuel filter minder.
- Dual alternator wiTECH improvements.
- Inducement timer reset procedure improvement.
- DEF refill detection calibration improvement.

If a customer describes the symptom/condition or if the technician finds any of the DTCs listed, perform the Repair Procedure: reprogramming the ECM/PCM with the latest software update.

CATEGORY 18**VEHICLE PERFORMANCE**

TSB#	MODEL	SUBJECT/DESCRIPTION																																																	
18-078-16 REV A 7/27/16	'16	<p><i>Engine Oil Viscosity Upgrade And Flash Enhancements</i></p> <p>This bulletin applies to vehicles built on or before June 30, 2016 and equipped with a 3.0-liter diesel engine.</p> <p>The following powertrain system improvements/enhancements are also included in this software release:</p> <ul style="list-style-type: none"> • Fan calibration. • Transmission calibration. • Revised oil change algorithm. <p>This bulletin involves reprogramming the Powertrain Control Module (PCM) and the Transmission Control Module (TCM). For vehicles in dealer inventory it also involves changing the engine oil with new 5W40 engine oil and applying a sticker to the engine oil filler cap. An addendum card will need to be added in the owner's manual.</p>																																																	
18-091-16 7/26/16	'13 DJ/D2	<p><i>Powertrain Diagnostic And System Improvements—Flash Update</i></p> <p>This bulletin applies to vehicles equipped with a 6.7-liter Cummins Turbo Diesel engine.</p> <p>Customers may experience a Malfunction Indicator Lamp (MIL) illumination. Upon further investigation the technician may find that the following Diagnostic Trouble Codes (DTCs) have been set. Several software improvements are available for the following conditions.</p> <p>The following DTC has been changed from a two trip fault to a one trip fault:</p> <p>U1A24 – Lost Communication With Ammonia Sensor</p> <p>Prevent or reduce MIL illumination when no defect is present for the following DTCs. These faults have been changed from a one trip fault to a two trip fault:</p> <table border="0"> <tr> <td>P0201</td> <td>P0202</td> <td>P0203</td> <td>P0204</td> <td>P0205</td> <td>P0206</td> <td>P049D</td> </tr> <tr> <td>P0711</td> <td>P0712</td> <td>P0713</td> <td>P0714</td> <td>P0740</td> <td>P0869</td> <td>P0933</td> </tr> <tr> <td>P0934</td> <td>P0935</td> <td>P1775</td> <td>P1776</td> <td>U0100</td> <td>U0002</td> <td></td> </tr> </table> <p>Improvements to prevent or reduce MIL illumination when no defect is present for:</p> <table border="0"> <tr> <td>P2281</td> <td>P218F</td> <td>P242F</td> <td>P20E8</td> <td>P202E</td> <td>P209F</td> <td>P218F</td> </tr> <tr> <td>P205E</td> <td>U110E</td> <td>P2281</td> <td>U3017</td> <td>P1477</td> <td>P20EE</td> <td>P026B</td> </tr> <tr> <td>P0128</td> <td>P0087</td> <td>U1421</td> <td>P026A</td> <td>P04DB</td> <td>P0544</td> <td>P0562</td> </tr> <tr> <td>P0604</td> <td>P1451</td> <td>P2201</td> <td>P24A5</td> <td>P2459</td> <td>P249E</td> <td></td> </tr> </table> <p>Other updates also include:</p> <ul style="list-style-type: none"> • Ambient Air Temperature (AAT) improvements. • NOx sensor calibration improvements. • Cap urea dosing at low temps. • SCR efficiency scan tool test improvement. • Transmission updates. • Alternator Dropout Threshold Set to 500rpm. • Warm Up Combustion Stability Improvement. • Urea Dosing during Stationary Regen. • Various Urea system calibration changes and cold weather system improvements and dosing heater thaw times. • Various additional wiTECH data and system test additions or improvements. • 68RFE Transmission shift quality improvements. • Cruise control system improvements. • System enhancements to starter lockout feature. • Erroneous "Service Exhaust System – see dealer" message setting with the ignition in the "Run" position, engine not running. • IM OBD II readiness – DTC P2002 improvements help Particulate Matter (PM) filter monitor group to be set to ready more often. 	P0201	P0202	P0203	P0204	P0205	P0206	P049D	P0711	P0712	P0713	P0714	P0740	P0869	P0933	P0934	P0935	P1775	P1776	U0100	U0002		P2281	P218F	P242F	P20E8	P202E	P209F	P218F	P205E	U110E	P2281	U3017	P1477	P20EE	P026B	P0128	P0087	U1421	P026A	P04DB	P0544	P0562	P0604	P1451	P2201	P24A5	P2459	P249E	
P0201	P0202	P0203	P0204	P0205	P0206	P049D																																													
P0711	P0712	P0713	P0714	P0740	P0869	P0933																																													
P0934	P0935	P1775	P1776	U0100	U0002																																														
P2281	P218F	P242F	P20E8	P202E	P209F	P218F																																													
P205E	U110E	P2281	U3017	P1477	P20EE	P026B																																													
P0128	P0087	U1421	P026A	P04DB	P0544	P0562																																													
P0604	P1451	P2201	P24A5	P2459	P249E																																														

CATEGORY 18 VEHICLE PERFORMANCE

<u>TSB#</u>	<u>MODEL</u>	<u>SUBJECT/DESCRIPTION</u>
-------------	--------------	----------------------------

18-091-16
Continued

- Add engine run time to fuel filter minder.
- Remove MIL for DTC; P1C70 – SCR Error Detected – Engine Disabled.
- Frozen CAC Diagnostic Improvement.
- WiTECH – Reset fix (PTO request on Pickup).
- WiTECH – Road governor speed upper limit adjustment.
- SCR Performance test fix.
- DEF refill detection calibration change.
- Grid heater inhibit operation correction.
- P0544 – Exhaust Gas Temperature Sensor Circuit – Bank 1 Sensor 1 – Does not clear correctly.
- Fuel filter minder distance trigger correction.
- Fuel system test improvements.
- Exhaust brake switch improvement.
- Cold idle stability improvement.
- Add ability to reset soot load after DPF replacement.
- Correct condition – Cruise control does not cancel at key off.

This bulletin involves reprogramming the Powertrain Control Module (PCM with the latest available software.

CATEGORY 19 STEERING

<u>TSB#</u>	<u>MODEL</u>	<u>SUBJECT/DESCRIPTION</u>
-------------	--------------	----------------------------

19-001-16 '16 DS
8/16/16

Electric Power Steering Gear With Low Assist

This bulletin applies to vehicles built between March 22, 2016 and April 9, 2016.

The customer may notice a low assist or excessive steering effort at lower speeds or parking lot maneuvers.

This bulletin involves replacing the electric power steering gear assembly.

CATEGORY 21 TRANSMISSION AND TRANSFER CASE

<u>TSB#</u>	<u>MODEL</u>	<u>SUBJECT/DESCRIPTION</u>
-------------	--------------	----------------------------

21-004-16 '16 DD/DP/D2
1/8/16

Transmission Shift And Drivability Enhancements—Flash Update

This bulletin applies to vehicles built on or before December 23, 2015 equipped with a 6.7-liter diesel engine and a 6-speed Aisin automatic transmission.

Some customers may experience one or more of the following conditions.

- A harsh 1-2 upshift.
- Excessive gear shifting.

This bulletin involves reprogramming the Transmission Control Module (TCM) with the latest available software.

CATEGORY 21**TRANSMISSION AND TRANSFER CASE**

<u>TSB#</u>	<u>MODEL</u>	<u>SUBJECT/DESCRIPTION</u>
21-017-16 REV A 7/30/16	'16 DS	<p><i>Transmission Shift And Drivability Enhancements—Flash Update</i></p> <p>This bulletin applies to vehicles built on or before June 24, 2016 equipped with a 3.0-liter Turbo Diesel engine and an 8-speed automatic transmission.</p> <p>Customers may experience a Malfunction Indicator Lamp (MIL) illumination. Upon further investigation, a technician may find the following Diagnostic Trouble Code (DTC) stored in the TCM memory:</p> <p>P0731 – Gear Ratio Error in 1st.</p> <p>The following enhancements are included in the software update:</p> <ul style="list-style-type: none">• 2-1 coast down improvement• 3-2 coast down improvement.• Improvement to 5-3 downshift with pedal to improve 5-3-2 shift.• 6-5 coast down improvement.• 2-3 upshift with less than a 30% pedal improvement.• Clutch C adaption stability improvement (improves shift quality for new transmissions on gear shifts that use Clutch C)• Garage shift to D improvements.• Rolling garage shift improvements.• Implementation of End Of Line (EOL) adaption to improve shift quality on brand new transmission.• Improved 7th gear upshift timing.• Downhill engine braking improvements. <p>This bulletin involves reprogramming the Transmission Control Module (TCM with the latest available software.</p>
21-025-16 7/6/16	'13-'16 D2	<p><i>Transmission Torque Converter Replacement After Drone Noise Verification</i></p> <p>This bulletin applies to vehicles built on or before April 13, 2016 equipped with a Cummins Turbo Diesel Engine and Aisin AS69RC HD transmission.</p> <p>The customer may describe a “heavy droning noise” coming from the vehicle at an engine speed range of 1,800rpm to 2,000rpm with mid to deep throttle applied. If the customer describes the symptom/condition listed above, test drive the vehicle and verify the noise. If the drone noise is verified, normal torque converter replacement should be performed.</p>
21-027-16 7/30/16	'16 D2/DD/DP	<p><i>Transmission Torque Converter Replacement Due to Dislodged Snap Ring</i></p> <p>This bulletin applies to vehicles built between March 29, 2016 and April 11, 2016 equipped with a Cummins Turbo Diesel Engine and Aisin AS69AR HD transmission.</p> <p>Customers may experience a Malfunction Indicator Lamp (MIL) illumination. Upon further investigation the technician may find the following Diagnostic Trouble Code (DTC) set in the Transmission Control Module (TCM) memory:</p> <p>P2757 – TCC Pressure Control Solenoid Control Circuit Performance</p> <p>This bulletin involves replacing the torque converter after verifying that an internal snap ring has dislodged.</p>

CATEGORY 23**BODY**

<u>TSB#</u>	<u>MODEL</u>	<u>SUBJECT/DESCRIPTION</u>
23-001-16 REV E 5/26/16	'15-'16 D2/DD/ DP/DS/DJ	<i>Center Console Lid Binding</i> This bulletin applies to vehicles built between early-April 2015 and early-October 2015 equipped with a Floor Console. This bulletin involves adding a rubber bumper to the console lid to prevent the lid from binding.
23-004-16 REV A 2/11/16	'15-'16 DS	<i>Tailgate Contacting Pickup Box Panel When Closing</i> This bulletin applies to vehicles built between February 14, 2015 and October 28, 2015. The customer may describe the tailgate making contact with the passenger side outer box panel. This bulletin involves adjusting the passenger side out box flange.
23-006-16 REV A 2/17/16	'16 DS	<i>Right Front Door Outer Belt Molding Too High</i> This bulletin applies to vehicles built between January 14, 2016 and January 20, 2016. The customer may describe that the outer belt molding is sitting too high on the door. This bulletin involves inspecting and if necessary, repairing the right front outer belt molding height.
23-007-16 2/17/16	'16 DS	<i>Water Entering Passenger Side Floor Area</i> This bulletin applies to DS vehicles built on or after December 13, 2015 and January 15, 2016. The customer may experience wet carpet in the right front footwell. This condition may be due to an insufficient adhesive bead between the aperture and cowl side. This bulletin involves applying sealant between the aperture and cowl to repair a water leak.
23-011-16 3/5/16	'16 DS/D2/DJ	<i>Sunroof Water Leak</i> This bulletin applies to vehicles built on or before December 8, 2015 equipped with Power Sunroof. An insufficient urethane bead around the metal bracket results in water leaking into the vehicle at one or both of the front corners of the sunroof. The repair procedure involves replacing the sunroof glass to repair a water leak from the sunroof.
23-033-15 8/22/15	'14-'15 DJ	<i>Rattle/Clunking/Popping Noise While Driving Vehicle On Uneven Roads</i> This bulletin applies to vehicles built on or before April 18, 2015. The customer may describe a rattle/clunking noise or popping that can be heard and felt in the floor under the front passenger or driver side when the vehicle is driven on uneven roads, especially from a higher level to a lower level. Noise may be more audible at cold temperature. This bulletin involves replacing the frame to body cushion isolators located under the right and left cab A-pillars.
23-037-15 19/14/15	All	<i>Windshield Wiper Blade/Element Maintenance</i> This is an "information-only" bulletin. Windshield wiper blades/elements are frequently replaced unnecessarily. Because of the environmental conditions vehicles can be operated in, a film can build up on both the windshield and the windshield wiper elements that will cause poor cleaning/streaking of the windshield, and in some instances, a chattering condition as the wiper blades travel across the windshield. Replacement of the wiper blades/elements is normally not required to correct the streaking issue. A simple normal maintenance cleaning of the wiper blades/elements and windshield is all that is required. <i>Editor's Note: There it is, the 2016 version of windshield wiper blade cleaning, TSB 23-037-15. Got it.</i>

CATEGORY 25**EMISSIONS CONTROL**

<u>TSB#</u>	<u>MODEL</u>	<u>SUBJECT/DESCRIPTION</u>
25-001-16 6/7/16	'13-'16 DD/ DJ/D2/DP	<p><i>Diagnosing A Urea Module That Is Exposed To Diesel Fuel</i></p> <p>This is an "information only" bulletin that discusses what will happen to the rubber material used in the urea pump when it is mistakenly exposed to diesel fuel.</p> <p>This unit is sometimes referred to as the Selective Catalyst Reductant (SCR) module or the Adblue Delivery Module (ADM). Units exposed to hydrocarbons have a particular failure mode, the rubber unit is crinkled and in some cases the metal heater protrudes through the rubber membrane.</p> <p>The rubber material used in this unit is designed to withstand Diesel Exhaust Fluid (DEF) only. Exposure to fluids that contain hydrocarbons (i.e. diesel fuel) will damage the unit beyond repair. Units returned that exhibit this failure mode will have warranty claims that are rejected.</p> <p>Units that exhibit this failure mode should be considered customer abuse and should not be covered under warranty. Use the Hydroscopic test paper (P/N 223-44-863) available through MoparEssentialTools.com to confirm exposure.</p>
25-003-14 9/6/14	'13-'15 DJ/ D2/DD/DP	<p><i>Information: P207F P1C70 And SCR Inducement Strategy</i></p> <p>A vehicle may come in with a Malfunction Indicator Lamp (MIL) illuminated. Upon inspection the technician may find the following Diagnostic Trouble Codes (DTCs) set in the Powertrain Control Module (PCM).</p> <p>P207F – Reductant Quality Performance P1C70 – SCR Error Detected – Engine Disabled</p> <p>These codes are set when the system detects inadequate DEF quality due to diluted, degraded, or contaminated fluid. As a result, the system will enter what is commonly called "Inducement Strategy." This is indicated by a message "5 MPH Max Speed in XXX Miles, Service DEF System, See Dealer" which will incrementally count down. Once the mileage countdown has expired, the EVIC will display "5 MPH Max Speed on Restart, Long Idle, or Refuel, Service DEF, See Dealer" followed by "5 MPH Max Speed, Service DEF System, See Dealer."</p> <p>In order to repair the vehicle, normal diagnostics should be performed for the DTC P207F and the root cause of the inadequate DEF quality corrected per published service information. However, once repaired and the codes have been cleared, the technician may find that DTC P1C70 will remain set and the EVIC message still displayed. To properly clear out the inducement message and reset the system the PCM should be flashed, using wiTECH, with the current most up to date calibration.</p>

2016 RECALL NOTICES

SAFETY RECALL R36/NHTSA 15V-459 STEERING WHEEL WIRING

Date: September 2015

Models/Production:

'12-'14 DS 1500
'12-'14 DJ 2500
'12-'14 D2 3500
'12-'14 DD 3500 Cab Chassis
'12-'14 DP 4500/5500 Cab Chassis

This recall applies only to the above vehicles equipped with an Electronic Vehicle Information Center (EVIC) (sales code LAZ) built through October 7, 2014.

Subject: The steering wheel wire harness on about 1,060,000 of the above vehicles may become chaffed by the driver airbag module retainer spring ends. A chaffed steering wheel wire harness could cause an electrical short and/or an inadvertent driver airbag deployment. Inadvertent driver airbag deployment, during certain driving conditions, may increase the risk of a crash and/or vehicle occupant injury.

Repair: The steering wheel wire harness will be inspected, and if needed, repaired. The steering wheel wire harness will be rerouted and secured to prevent wire chaffing and protective caps will be installed onto the airbag retainer spring ends.

SAFETY RECALL R40/NHTSA 15V-461 RADIO SECURITY VULNERABILITY

Date: September 2015

Models/Production:

'13-'15 DS 1500
'13-'15 DJ 2500
'13-'15 D2 3500
'13-'15 DD 3500 Cab Chassis
'13-'15 DP 4500/5500 Cab Chassis

This recall applies to the above vehicles equipped with a Uconnect 8.4" screen radio built through July 23, 2015.

Subject: The radios on about 1,410,000 of the above vehicles have certain software security vulnerabilities which could allow unauthorized third-party access to some networked vehicle control systems. Exploitation of the software security vulnerabilities could lead to exposing the driver, the vehicle occupants or any other individual or vehicle with proximity to the affected vehicle to a potential risk of injury.

Repair: The radio software must be updated to remove the security vulnerability condition.

SAFETY RECALL R23/NHTSA 15V-460 REPROGRAM OCCUPANT RESTRAINT CONTROL MODULE

Date: August 2015

Models/Production:

'13-'15 DS 1500

This recall applies to the above vehicles built at the Warren Assembly Plant through January 26, 2015.

'13-'15 DS 1500
'13-'15 DJ 2500
'13-'15 D2 3500

This recall applies to the above vehicles built at the Saltillo Assembly Plant through December 8, 2014.

Subject: Occupant Restraint Control (ORC) module software on about 667,000 of the above vehicles may contain side impact calibrations that are overly sensitive. Inadvertent Side Airbag Inflatable Curtain (SABIC). Seat airbag, and/or seatbelt pretensioner deployment during certain driving conditions may increase the risk of a crash and/or vehicle occupant injury.

Repair: The ORC module must be reprogrammed with new software.

SAFETY RECALL R47/NHTSA 15V-534 SIDE AIRBAG INFLATABLE CURTAIN

Date: September 2015

Models/Production:

'14-'15 DS 1500 Quad Cab

This recall applies only to the above vehicles built through August 8, 2015.

Subject: The right and left Side Airbag Inflatable Curtains (SABIC) on about 188,000 of the above vehicles may not deploy as intended. An improperly deployed SABIC, during certain crash events, could allow additional injuries to rear seat occupants.

Repair: A foil patch will be installed on each side of the headliner and the right and left Side Airbag Inflatable Curtains will be inspected for proper orientation. In a small number of cases, one or both of the Side Airbag Inflatable Curtains may need to be replaced.

SAFETY RECALL R43/NHTSA 15V-517 BATTERY WIRE HARNESS

Date: October 2015

Models/Production:

'14 DS 1500 Series

This recall applies only to the above vehicles equipped with a 3.0-liter diesel engine and 4x2 drivetrain built at the Warren Assembly Plant from August 8, 2013 through June 13, 2014.

'13-'15 DS 1500 Series

This recall applies only to the above vehicles equipped with a 3.0-liter diesel engine and 4x2 drivetrain built at the Saltillo Assembly Plant.

Subject: The battery (B+) wire harness on about 1,650 of the above vehicles may have been routed against the right engine mount frame bracket. Continuous battery wire harness contact with the right engine mount frame bracket could cause the battery wire harness sheathing to wear and create a highly resistive short circuit. A highly resistive short circuit could cause the vehicle to stall and/or an underhood electrical fire.

Repair: The battery wire harness must be inspected for a rub through of the wire harness. Trucks found with a damaged battery wire harness must have the battery wire harness replaced.

**SAFETY RECALL R46/NHTSA 15V-541
FRONT SUSPENSION TRACK BAR FRAME BRACKET**

Date: February 2016

Models/Production:

'13-'14 D2 3500

'14 DD 3500 Cab Chassis

'14 DJ 2500

This recall applies only to the above vehicles built from October 9, 2012, through July 29, 2014.

Subject: The front suspension track bar frame bracket on about 149,500 of the above vehicles may have been improperly welded to the frame rail during the manufacturing process. The front suspension track bar frame bracket welds may break and allow the front suspension track bar frame bracket to separate from the frame rail. A separated front suspension track bar frame bracket will cause diminished steering response and could cause a crash without warning.

Repair: The front suspension track bar frame bracket welds must be inspected. Vehicles found with cracked and/or separated welds must have the track bar frame brackets reviewed to determine if they should be repaired, replaced or no action is required before the reinforcement package is installed.

**SAFETY RECALL R32/NHTSA 16V-301
FRONT HALFSHAFTS**

Date: July 2016

Models/Production:

'16 DS 1500

This recall applies only to the above vehicles equipped with four wheel drive built from February 19, 2016, through March 1, 2016.

Subject: The front halfshafts on about 90 of the above vehicles may not have been heat treated properly during the manufacturing process. An improperly heat treated halfshaft could fracture without warning. A fractured halfshaft could damage underbody components and cause a crash without warning.

Repair: Both front halfshafts must be replaced.

**EMISSIONS RECALL R369
SELECTIVE CATALYTIC REDUCTION CATALYST**

Date: July 2016

Models/Production:

'14 DS 1500 Series

This recall applies only to the above vehicles equipped with a 3.0-liter diesel engine.

Subject: The Selective Catalytic Reduction (SCR) catalyst on about 11,400 of the above vehicles is experiencing washcoat degradation, which may lead to the exceedance of exhaust emission standards.

Repair: The SCR catalyst must be replaced.

**SAFETY RECALL R48/NHTSA 16V-495
TRANSFER CASE REAR OUTPUT SHAFT**

Date: August 2016

Models/Production:

'16 DD 3500 Cab Chassis

'16 DP 4500/5500 Cab Chassis

This recall applies to the above vehicles equipped with a Transfer Case – Manual Shift or Electronic Shift and 6-Speed Automatic Transmission or 6-Speed Manual Transmission built from July 24, 2015, through January 7, 2016.

Subject: The transfer case rear output shaft on about 650 of the above vehicles could fracture while driving. A fractured rear output shaft will result in a loss of motive power and a loss of "Park" functionality when the vehicle is operated in two-wheel drive mode. The loss of "Park" functionality could cause unintended vehicle movement. This could cause a crash and/or strike bystanders near the vehicle.

Also, 144.5" wheelbase trucks equipped with a one-piece rear propeller shaft may experience propeller shaft separation if the transfer case rear output shaft fractures. This could cause a crash without warning while driving.

Repair: The transfer case must be replaced on all involved vehicles.

TECHNICAL SERVICE BULLETINS ISSUED DURING 2017

CATEGORY 2 FRONT SUSPENSION

TSB#	MODEL	SUBJECT/DESCRIPTION
02-006-16 10/29/16	'13-'17 D2 '14-'17 DJ/DD	<p><i>Toe Adjustment - Recirculating Ball Steering System</i></p> <p>This information-only bulletin discusses that the vehicles identified have a drag link with an adjustment sleeve and jam nuts, which differs from the previous clamp and bolt style.</p> <p>The purpose of the bulletin: When tightening the drag link jam nuts, the adjuster sleeve must always be held secure with a wrench/tool.</p> <p>Editor's note: Yes, the TDR is supposed to entertain even while it instructs, right? If a service technician is not aware of the preceding "proper repair technique," perhaps other careers should be considered.</p>

CATEGORY 8 ELECTRICAL

TSB#	MODEL	SUBJECT/DESCRIPTION
08-070-16 9/2/16	'13-'14 DS/DJ/D2	<p><i>RG3 RG4 RJ3 RJ4 Radio Enhancements</i></p> <p>This bulletin applies to vehicles equipped with one of the following radios:</p> <ul style="list-style-type: none"> Uconnect 8.4 Sales Code RG3 Uconnect 8.4 Sales Code RG4 Uconnect 8.4 Sales Code RJ3 Uconnect 8.4 Sales Code RJ4 <p>A list of 63 problems with the 8.4 radio are identified in this bulletin. From "Loss of parental control under APPS menu" to "Black screen intermittently displayed," the TSB calls for an inspection and flash/update of the 8.4 radio.</p>
08-073-16 9/1/16	'16 D2/DJ/ DD/DP/DS	<p><i>Flash: Instrument Panel Cluster (IPC) Enhancement</i></p> <p>This bulletin applies to vehicles built on or before August 15, 2016, and equipped with one of the following Sales Codes:</p> <ul style="list-style-type: none"> (JA4) Instrument Cluster (JAT) Instrument Cluster W/Display Screen (JAJ) Rebel Instrument Cluster (JA3) Instrument Cluster W/Unique Display (JA6) Electroluminescent Instrument Cluster (JA1) Instrument Cluster W/Unique Display (JAX) Laramie Longhorn Instrument Cluster (JAV) Laramie Limited Cluster <p>The customer may describe one or more of the following:</p> <ul style="list-style-type: none"> • Instrument cluster backlighting may start flickering. This usually occurs when the dimming is in the lower settings (high-line instruments panels only). • The cruise control set speed does not match the digital speedometer (BUX vehicles only). <p>This bulletin involves updating the Instrument Panel software and updating Radio Frequency Hub Module (RFHM) software to latest version.</p>
08-076-16 9/22/16	'16 DP/DD/ D2/DJ/DS	<p><i>Remote Start Antenna Replacement</i></p> <p>This bulletin applies to vehicles built on or after June 20, 2016 and on or before June 23, 2016, equipped with Remote Start (Sales Code XBM).</p> <p>This bulletin involves replacing the remote start antenna module.</p> <p>Editor's note: Yes, the TDR is supposed to entertain? Looks like the different Ram factories received a bad batch (three days' worth) of parts from a vendor. Just look at the paperwork churn that the bad parts created. A rapid response is necessary by the dealer network to correct the problem prior to the sale of the vehicle.</p>
08-080-16 Rev A 11/23/16	'16 DP/DD/ D2/DJ/DS	<p><i>Body Control Module (BCM) Diagnostic and System Improvements Software Flash</i></p> <p>This bulletin applies to vehicles built on or before May 24, 2016. The customer may describe the headlamps flicker while operating at night. This condition may be more prevalent after the bulb(s) have been replaced with an aftermarket bulb.</p> <p>This bulletin involves updating the Body Control Module (BCM) software.</p>

CATEGORY 8**ELECTRICAL**

TSB#	MODEL	SUBJECT/DESCRIPTION
08-082-16 10/18/16	'15-'16 DP/DD/ D2/DJ/DS	<p><i>Integrated Trailer Brake Module Software Enhancement Software Flash</i></p> <p>This bulletin applies to vehicles built on or before April 13, 2016, equipped with Trailer Brake Control (Sales Code XHC). The customer may describe an intermittent condition where the trailer brakes feel as if they are not working for the first few brake applies. This condition only happens if the trailer has been connected before the vehicle was started.</p> <p>If the customer describes the symptom/condition listed above, the correct repair procedure is a flash/update to the truck's Integrated Trailer Brake Control Module (ITBM).</p>
08-085-16 10/29/16	'17 DS	<p><i>Headlamps and Wheel Alignment Are Out of Adjustment.</i></p> <p>This bulletin applies to vehicles built on October 3, 2016. The customer may describe that the headlamps are out of alignment, the steering wheel is off center or there is premature front tire wear.</p> <p>This bulletin involves adjusting the headlamps and correcting the wheel alignment to proper specifications.</p> <p>Editor's note: More entertainment... Looks like another bad day at the assembly plant and "Factory Location 13X" has caused another paperwork flurry and the corresponding rapid response by the dealer network.</p>
08-003-17 1/10/17	'12 D2/DJ/ DD/DP/DS	<p><i>RBZ or RHB Radio Enhancements</i></p> <p>Customers may experience one or more of the following:</p> <ul style="list-style-type: none">• When changing the language on the radio, the navigation may still display English.• Help prevent navigation lockup.• Ghost image of the vehicle's brand logo on the display screen.• Digital photos loaded onto the hard drive intermittently get lost.• Sirius audio pop on power up.• HFM audio pop on power up.• HFM Mode resume with no information. <p>For RHB Radios Only:</p> <ul style="list-style-type: none">• Trip planner does not save a route after it was created.• Route guidance does not activate after the vehicle shuts down.• Longitude entry does not allow enough digits.• CD/DVD will not play.• Navigation accept screen will not clear.• Navigation shows "acquiring signal" for an extended period of time.• New navigation graphics. <p>This bulletin involves reprogramming RBZ or RHB radios with the latest available software.</p>
08-011-17 2/2/17	'15 D2/DJ/ DP/DS	<p><i>RG2 or RJ2 Radio Software Enhancements</i></p> <p>This bulletin applies to vehicles built on or before June 29, 2015 equipped with UConnect 5.0 (sales code RJ2) or UConnect 5.0 (sales code RG2).</p> <p>A customer may experience one or more of the following:</p> <ul style="list-style-type: none">• Radio display screen intermittently may go blank.• Radio display screen may be locked.• Backup display may not turn off.• Audio Mutes.• Not able to change state of heated seats and/or steering wheel during stop event on Stop/Start vehicles.• Touchscreen confirmation beep may be too loud.• The radio does not allow selection of the Polish language.• The radio fan continually runs at high speed.• Customer perception may be the radio fan is too loud. <p>Improvements:</p> <ul style="list-style-type: none">• Only allow vehicle settings to be changed in run mode. To help ensure settings are properly saved.• Always gray out text message soft keys for non-supporting devices.• Voice Recognition (VR) improved accuracy. <p>If the customer describes the problem(s) listed above the correct repair procedure involves updating the radio software.</p>

CATEGORY 8**ELECTRICAL**

TSB#	MODEL	SUBJECT/DESCRIPTION
08-12-17 2/2/17	'15 DS/DJ/ D2/DD/DP	<p><i>RA2 Radio Software Enhancements</i></p> <p>This bulletin applies to vehicles built on or before June 29, 2015 equipped with UConnect 5.0 (sales code RA2)</p> <p>A customer may experience one or more of the following:</p> <ul style="list-style-type: none">• Radio display screen intermittently may go blank.• Radio display screen may lock up.• Backup display may not turn off.• Audio Mutes.• Not able to change state of heated seats and/or steering wheel during stop event on Stop/Start vehicles. <p>Improvements:</p> <ul style="list-style-type: none">• Only allow vehicle settings to be changed in run mode. To help insure settings are properly saved.• Always gray out text message soft keys for non-supporting devices.Voice Recognition (VR) improved accuracy.• If the customer describes the problem(s) listed above the correct repair procedure involves updating the radio software.
08-016-17 2/9/17	'16 DS/DJ/ D2/DD/DP	<p><i>Radio Software Enhancements</i></p> <p>This bulletin applies to vehicles equipped with UConnect 5.0 (sales codes RA2, RG2, RJ2, RK2, RL2, or RM2).</p> <p>A customer may experience one or more of the following:</p> <ul style="list-style-type: none">• Bluetooth communication with the passenger is poor.• Radio display screen may intermittently go blank.• Radio display screen may lock up.• Back up display may not turn off.• Loss of radio memory for skipped channels or incorrectly displaying skipped channels in the menu list. <p>This bulletin involves updating the radio's software.</p>
08-017-17 2/10/17	'15 DS/DJ/ D2/DD/DP	<p><i>BCM Diagnostic and System Improvements: Flash Update</i></p> <p>The customer may describe the headlamps flicker while operating at night. This condition may be more prevalent after the bulb(s) have been replaced with an aftermarket bulb.</p> <p>The bulletin involves updating the Body Control Module (BCM) software.</p>
08-019-17 2/21/17	'15 DS/DJ/D2	<p><i>RG3 RG4 RJ3 RJ4 Radio Enhancements</i></p> <p>A small number of customers may experience one or more of the following:</p> <ul style="list-style-type: none">• Radio may keep the CAN bus network awake, causing a battery drain.• Voice Recognition (VR) to set temperature, will indicate wrong setting to rear seat temperature.• Teleprompter does not appear when pressing the VR button.• VR operation cancels while in media mode.• Radio may display camera's previous image before displaying the current image.• Navigation lost vehicle position during route calculation.• Navigation displays are missing after vehicle heading changes.• Navigation giving incorrect guidance to exit the highway.• FM audio may switch to AM after ignition cycle.• Text messages appear as sender's phone number, not their name.• VR phone button may not work at times.• Audio muted after AUX device is disconnected.• VR "Listen" to text will only play first message.• Speed adjusted volume may not work.• AM/FM seek or tuner soft keys may be missing.• Display screen shows ambient temperature as "- -" not normal values. <p>This bulletin involves inspecting and, if required, updating the radio software.</p>

CATEGORY 8**ELECTRICAL**

<u>TSB#</u>	<u>MODEL</u>	<u>SUBJECT/DESCRIPTION</u>
08-028-17 3/17/17	'13-'16 D2/ DD/DJ/DS	<p><i>RA3 and RA4 Radio Over the Air Software Updates</i></p> <p>This bulletin applies to vehicles equipped with Uconnect 8.4 (sales code RA3) or Uconnect 8.4AN (sales code RA4). All model year '13-'16 vehicle sold in the US with the RA3 or RA4 radio can now receive software updates "over-the-air". Updates to software level 17.11.07 will occur in a phased roll-out. The software is updated through the built-in cellular modem in the radio which is connected to the Sprint 3G network. Customers will see a notification on their radio screen when new software is available for their radio. The owner will have the option to update the radio or schedule the update for later. There is not an option to decline the update indefinitely. The update must be performed.</p> <p>The following improvements are included in this update:</p> <ul style="list-style-type: none">• Auto Play can now be configured.• Adds do not disturb text message feature.• The ability to drag and drop icons into the menu bar.• Fix for radio locks up/frozen.• Fix for stuck on black/blank screen.• Several navigation improvements.• Fix for radio loses time.• Media devices, phone pairing and Bluetooth usage improvements.• Improved tuner performance.• Enhanced voice recognition (VR) performance.• Enhancements in connectivity apps.
08-046-17 6/8/17	'16 DS/DJ/ DD/DP/D2	<p><i>RA3 and RA4 Radio Enhancements</i></p> <p>This bulletin applies to vehicles equipped with Uconnect 8.4 (sales code RA3) or Uconnect 8.4AN (sales code RA4).</p> <p>Customers may experience one or more of the following:</p> <ul style="list-style-type: none">• Navigation Failed message is displayed.• Navigation is inoperative or inaccurate.• CD player will not play songs and/or locks up the radio.• Clock will not automatically update to local time.• Clock may be off by several hours. (RA3 only.)• Some Uconnect remote commands do not execute with the vehicle.• Radio Apps are inoperative.• Adds Apple Siri Eye Free capability for iPhone owners.• Auto play can now be configured.• Radio will lock up.• Radio display screen is black or blank.• Battery drain – due to radio staying on. <p>Improvements:</p> <ul style="list-style-type: none">• Add the ability to drag and drop icons into the menu bar.• Enhanced voice recognition (VR) performance.• Media devices, phone pairing, and Bluetooth usage improvements.• Improved tuner performance.• Enhancements in Connectivity Apps.• Adds "do not disturb" text message feature.• Satellite radio reception improvements. <p>The bulletin involves reprogramming the RA3/RA4 radio with the latest update.</p>

CATEGORY 8**ELECTRICAL**

TSB#	MODEL	SUBJECT/DESCRIPTION
08-047-17 6/10/17	'15 (DS/DJ/D2/ DD/DP)	<i>RA3/RA4 Radio Software Enhancements/Flash Update</i> This bulletin applies to vehicles equipped with one of the following radios: <ul style="list-style-type: none"> • Uconnect 8.4A (Sales Code RA3) • Uconnect 8.4AN (Sales Code RA4)

A small number of customers may experience one or more of the following:

- Navigation Failed" message is displayed.
- Navigation is inoperative or inaccurate.
- CD player will not play songs and/or locks up the radio
- The clock will not automatically update to local time.
- The clock may be off by several hours (RA3 only).
- HVAC temperature out of sync with radio display (KL vehicles).
- Some Uconnect App remote commands do not execute with the vehicle.
- Radio Apps are inoperative.
- Radio will lock up.
- Radio display screen is black or blank.
- Battery drain due to radio staying on.
- Rearview Camera image appears jittery (UF vehicles only).
- Inability to establish a WiFi connection when security feature is enabled (UF vehicles only).
- Audio distortion/popping heard while playing Apple devices through the USB port (UF vehicles only).
- Remote Uconnect Apps functions (i.e. door locks, remote start) inoperative while the engine is running (UF vehicles only).
- HVAC temperature out of sync with radio display (KL vehicles).
- Intermittently blind spot chime will not turn off (KL vehicles only).
- The radio may switch from SiriusXM to an AM station by itself.
- Uconnect registration always present, cannot remove Uconnect account.
- Teleprompter does not appear when pressing the Voice Recognition (VR) button.
- VR operation cancels while in media mode.
- The radio may display previous image before displaying the current image.
- Navigation lost vehicle position during route calculation.
- Navigation displays are missing after vehicle heading changes.
- Navigation giving incorrect guidance to exit the highway.
- FM audio may switch to AM after ignition cycle.
- Text messages appear as sender's phone number not their name.
- VR phone button may not work at times.
- Audio muted after AUX device is disconnected.
- VR, "Listen" to text will only play first message.
- Drive Mode: Eco, sport or normal setting may not be saved after key cycle (LA, LD, LX and ZD only)
- SiriusXM station information does not update.
- Speed adjusted volume may not work.
- AM or FM seek or tuner soft keys may be missing.
- Display screen shows ambient temperature as "- ." not normal values.

In addition, the following improvements are included:

- Adds Apple Siri Eyes Free capability for iPhone owners.
- Add the ability to drag and drop icons into the menu bar.
- Auto Play can now be configured.
- Enhanced VR performance.
- Media devices, phone pairing and Bluetooth usage improvements.
- Improved tuner performance.
- Enhancements in Connectivity Apps (Yelp, Pandora, Aha, etc.).
- Human Machine Interface (HMI) improvements.
- Adds "do not disturb" text message feature.
- User can pair iPhone with Uconnect via Bluetooth and talk to Siri through Uconnect.
- Ability to press VR button for more than one second.
- Keyboard improvements in the Points Of Interest (POI) section.
- High Definition (HD) radio buffering.
- Spanish translation.
- Radio station scroll feature.
- Drive Mode: Launch control button, text improvements (LA, LD, LX and ZD only).
- Making assist calls.
- Enable the High Definition (HD) feature (RA4 only).
- App functionality and screen displays.
- Displays correct media, song titles and tracks.
- Travel Link Points Of Interest (POI), displaying movies and favorites.
- Incoming calls, audio enhancements (LA, LD and LX only).
- Audio for strong AM stations.
- VR performance
- Settings can only be changed in run mode, not ACC.
- Notify user when messaging features are not supported on certain phones/devices.
- Shows direction and distance for POI when using VR.

The bulletin involves inspecting and updating the radio software.

CATEGORY 8**ELECTRICAL****TSB# MODEL SUBJECT/DESCRIPTION**

08-053-17 '17 (DS/D2/DD/
Rev. A DJ/DP)
7/15/17

RA 3 and RA4 Radio Enhancements
This bulletin applies to the following vehicles:

- For DS vehicles built on or before May 16, 2017 equipped with Uconnect 8.4 (RA3) or 8.4AN (RA4).
- For D2, DD and DP vehicles built on or before May 26, 2017 equipped with Uconnect 8.4 (RA3) or 8.4AN (RA4).
- For DJ vehicles built on or before May 16, 2017 equipped with Uconnect 8.4 (RA3) or 8.4AN (RA4).

Customers may experience one or more of the following:

- “Navigation Failed” message is displayed.
- Navigation is inoperative or inaccurate.
- CD player will not play songs and/or locks up the radio
- The clock will not automatically update to local time.
- The clock may be off by several hours (RA3 only).
- Poor or no connection to cellular network.
- Charge Complete notification is not received (RU PHEV only).
- Some Uconnect App remote commands do not execute with the vehicle.
- Radio Apps are inoperative.
- Radio will lock up.
- Radio display screen is black or blank.
- Battery drain—due to radio staying on.
- Navigation failed message is displayed.
- Clock not automatically updating to local time

Improvements:

- Auto Play can now be configured.
- Media devices, Phone pairing and Bluetooth usage improvements.
- Add the ability to drag and drop icons into the menu bar.
- Adds “do not disturb” text message feature.
- Fix for radio locks up/frozen.
- Fix for radio loses time.
- Enhanced Voice recognition (VR) performance.
- Media devices, phone pairing and Bluetooth usage improvements.
- Improved tuner performance.
- Human Machine Interface (HMI) improvements.
- Satellite radio reception improvements.

The bulletin involves inspecting and updating the radio software.

08-071-17 '13-'14 DS/DD/
8/10/17 DJ/DP/D2

RA3 RA4 Radio Enhancements
This bulletin applies to vehicles equipped with one of the following radios:
• Uconnect 8.4A (Sales Code RA3)
• Uconnect 8.4AN (Sales Code RA4)

A customer may experience one or more of the following conditions:

- “Navigation Failed” message is displayed.
- Navigation is inoperative or inaccurate.
- CD player will not play songs and/or locks up the radio
- The clock will not automatically update to local time.
- The clock may be off by several hours (RA3 only).
- HVAC temperature out of sync with radio display (KL vehicles).
- Some Uconnect App remote commands do not execute with the vehicle.
- Radio Apps are inoperative.
- Adds Apple Siri Eyes Free capability for iPhone owners.
- Auto Play can now be configured.
- Radio will lock up.
- Radio display screen is black or blank.
- Battery drain due to radio staying on.
- HVAC temperature out of sync with radio display (KL vehicles).
- Track names may be displayed twice in USB or SD media modes.
- SD, USB, or BTSA modes may become non-functional for a given ignition cycle.
- Duplicate song titles may be displayed in USB mode.
- Last track is displayed but next track is being played.
- Navigation function may reset itself after using One-Shot VR.
- Intermittently the Global Positioning System (GPS) may lose its location for a short time and causes routing and positioning concerns.
- GPS and Internal cellular device may become inoperative and causes a loss of GPS and cellular functions.
- A false Pop-up message may appear “Vehicle Phone Requires Service” even though the vehicle’s phone works properly.
- Back-up camera image may be unclear or jittery/stutters at times.
- Mute button status was not being displayed correctly.
- Presets were not shown correctly or were deleted.
- Park Sense tone continuously on.
- Radio display may show “Please insert USB Stick.”
- Navigation may not start or may lose position.
- Rear camera may show a black screen for 3 seconds upon going to reverse.
- iPod would not resume playing after a VR session or phone call.
- Radio reset, screen lockup, blank screen or sluggish system response time.
- Compass indicator turns off.
- Touch screen shut down message.
- Radio surround sound will not stay ON.
- Driver memory feature causes Sirius XM failure.

CATEGORY 8 ELECTRICAL

TSB#	MODEL	SUBJECT/DESCRIPTION
08-094-17 9/28/17	'13-'14 DS/DJ/D2	<i>RG3, RG4, RJ3, RJ4 Radio Enhancements</i>
		This bulletin applies to vehicles equipped with one of the following radios: Uconnect 8.4 radio sales codes RG3, RG4, RJ3, RJ4.

This bulletin applies to vehicles equipped with one of the following radios: Uconnect 8.4 radio sales codes RG3, RG4, RJ3, RJ4.

Customers may experience one or more of the following.

- “Navigation Failed” message is displayed.
- Clock does not automatically update to local time.
- Poor or no connection to cellular network.
- HVAC temperature out of sync with radio display.
- Some Uconnect App remote commands do not execute with the vehicle.
- Display goes blank/black.
- Cyrillic keyboard is missing in phone book.
- Incorrect speed limit on NAV speed camera indication.
- Poor reception for AM/FM radio.
- Duplicate song titles may be displayed in USB mode.
- Last track is displayed but next track is being played.
- SD, USB, or BTSA modes may become non-functional for a given ignition cycle.
- Track names may be displayed twice in USB or SD media modes.
- Voice Recognition (VR) command “Set Temperature” may not respond in Fahrenheit. United Kingdom (UK) Vehicle only.
- DAB is inoperative
- Wrong routing for addresses with a longitude between 0 and -1 degrees.
- Speed camera UK and Spain complaining that the speed camera feature was not available with the latest MY14 software.
- SRT soft button missing for radios when vehicle is equipped with SRT feature.
- Battery drain due to the radio and cluster back-lighting staying on.
- Postal Code smart speller logic enhancements
- AM/FM steering wheel mode switch button not working.
- Navigation Lockout Disable while vehicle is in motion.
- Removed network status indicators for SRT/APPS.
- VR says ‘cancel’ when starting applications.
- iPod would not resume playing after a VR session or phone call.
- Removed the cell signal indicator in the SRT and Apps button on non-US vehicles.
- Rear camera may show a black screen for 3 seconds upon going to reverse.
- Navigation would not start or would lose position.
- Removal of parental control under Apps menu.
- Turn by Turn navigation in the cluster set to ON by default.
- Transfer button does not pick-up and transfer incoming call.
- Some Russian letters are caps when they should be lower-case.
- Touch screen locks up in navigation, when Russian is selected.
- Address search available when the vehicle is moving.
- Recognition enhancement for Russian.
- Hands free audio too low for non-amp vehicle.
- Intermittently “Registration expired” pop-up appears on display screen.
- Arabic language for navigation only, not the keyboard.
- Incorrect time to destination, when ignition is cycled.
- Volume adjustment for navigation prompts, for phone call.
- Incorrect rear to center fade displayed at start up.
- Translation enhancements for French, German and Spanish.
- Right arrow doesn’t work for advancing through preset.
- Map zoom level reduced.
- Park sense audio tone stuck on.
- While in media the browser knob is disabled.
- Various POI not available for navigation
- Postal code search not working in some markets.
- “Horn Sounds When Locked” is missing in the settings menu.
- Mute button out of sync with mute in the hands free phone.
- Enhancements to correct hands free phone locking up.
- Enhancements to quick search.
- Rear view camera active guide lines are missing.
- Erratic Interior ambient lamp menu being displayed.
- Remove auto entry/exit from menu.
- Remove hiss start assist from menu, when not available.
- Russian keyboard enhancements.
- Polish text update.
- Black screen intermittently displayed.
- VR Teleprompter translations.
- Splash screen not showing after remote unlock.
- Translation enhancement for Spanish, German, French and Russian.
- Russian letters are in caps when they should be in lower case.
- Navigation locks up when Russian is selected.
- VR Spanish language talks too fast when giving instructions.
- Arabic language added to some features (RJ3 and RJ4 radios only).
- VR enhancements for Russian.
- Route guiding enhancements.
- HVAC display enhancements.

In addition, the following improvements are included:

- German translation.
- Bluetooth fixes for loading hands free message (2014 MY WK and KL with RG4)
- User can pair iPhone with Uconnect via Bluetooth and talk to Siri through Uconnect.
- Tuner reception software enhancements.
- HVAC temperature out of sync with radio display fix.

This bulletin involves inspecting and updating the radio software, if required.

CATEGORY 8**ELECTRICAL**

<u>TSB#</u>	<u>MODEL</u>	<u>SUBJECT/DESCRIPTION</u>
08-053-17 Rev. A 7/15/17	'17 (DS/D2/DD/ DJ/DP)	<p><i>UAS, UAQ, UCS, and UCQ Radio Over The Air Software Updates</i></p> <p>This bulletin applies to vehicles built on or before October 6, 2017 and equipped with one of the following radios. Uconnect 4C (sales codes UAS, UCS, UAQ, UCQ).</p> <p>This bulletin provides information regarding the latest Flash Over The Air (FOTA) update and provides the service technician an overview of the steps a customer will need to take to complete the update.</p> <p>The following enhancement is included in this update:</p> <ul style="list-style-type: none"> • Improved sound quality when using the Bluetooth phone.

CATEGORY 9**ENGINE**

<u>TSB#</u>	<u>MODEL</u>	<u>SUBJECT/DESCRIPTION</u>
09-003-17 4/1/17	'17 DJ/ D2/DD/DP	<p><i>Cummins Injector Repair – 6.7-liter Engine</i></p> <p>This bulletin applies to vehicles built on or later November 23, 2016 and on or before March 17, 2017.</p> <p>Customers may experience a malfunction indicator lamp (MIL) illumination. Upon further investigation the technician may find one of the following diagnostic trouble codes (DTCs) have been set:</p> <p>P0201 – Fuel Injector 1 Circuit/Open P0202 – Fuel Injector 2 Circuit/Open P0203 – Fuel Injector 3 Circuit/Open P0204 – Fuel Injector 4 Circuit/Open P0205 – Fuel Injector 5 Circuit/Open P0206 – Fuel Injector 6 Circuit/Open</p> <p>This bulletin involves inspecting the injector terminal post for errant wire/shavings that could cause a grounded-out condition. Testing and possibly replacing fuel injectors.</p>
09-004-17 6/17/17	'14 DS	<p><i>Intermittent Engine Shudder While Driving</i></p> <p>This bulletin applies to vehicles equipped with the 3.0-liter Turbo Diesel engine. A small number of customers may experience a slight engine shudder while driving. They may state that the condition feels and sounds like driving over rumble strips. It may also be perceived as an internal transmission issue or engine misfire. No Diagnostic Trouble Codes (DTCs) will set as a result of this condition. Valve stem seals on replacement head are designed to prevent excessive carbon build up from light load drive cycles. Although it may be hard to reproduce, engine shudder resulting from these excess carbon deposits, will typically only happen under the following driving conditions:</p> <ul style="list-style-type: none"> • Steady speeds between 50 and 70mph. • Engine speed between 1600-2000 RPM. • Present during engine warm up to operating temperature after a cold soak. • Only present for a few seconds at a time and often during a 6-7 upshift. • Light load acceleration or while driving up a slight grade. • Symptom will go away either by aggressively applying the accelerator pedal or going into a zero throttle deceleration. <p>The bulletin involves replacing the engine cylinder heads.</p>

CATEGORY 14 FUEL SYSTEM

<u>TSB#</u>	<u>MODEL</u>	<u>SUBJECT/DESCRIPTION</u>
14-003-17	'17 DS	<p><i>Fuel Weeping From Number Three Cylinder Injector Return Hose</i></p> <p>Some customers may experience a fuel smell and/or weepage. Upon further investigation, a technician may notice the issue emanating from under the hood at the number three cylinder injector return hose connector.</p> <p>This bulletin applies to vehicles built on or after June 27, 2017, or before August 2, 2017, with a 3.0 EcoDiesel engine.</p> <p>This bulletin involves inspecting the fuel return line connections at the number three cylinder fuel injector and making the repair, as necessary.</p>

CATEGORY 18 VEHICLE PERFORMANCE

<u>TSB#</u>	<u>MODEL</u>	<u>SUBJECT/DESCRIPTION</u>
18-099-16 9/2/16	'15 DD/DP	<p><i>6.7-liter Diagnostic and System Improvements Flash Update</i></p> <p>This bulletin involves reprogramming the Engine Control Module (ECM) with the latest available software.</p> <p>There will be a choice between two calibrations. One for vehicles that utilize an ammonia sensor and one for vehicles that have had the ammonia sensor removed. Be sure to select the correct software based on vehicle configuration.</p> <p>The software improvements are designed to prevent or reduce Malfunction Indicator Lamp (MIL) illumination when no defect is present for the following Diagnostic Trouble Codes (DTCs):</p> <p style="text-align: center;">P20EE P1C55 P218F P242F U110E P205E P20E8 U3017 U2421 P2281</p> <p>Other Software Improvements:</p> <ul style="list-style-type: none">• Ambient Air Temperature Improvements.• Operational Improvement for Dual Alternators.• Selective Catalytic Reductions (SCR) Efficiency scan tool test improvement.• Fuel Filter Minder calibration changes.• wiTECH Fuel Pressure Override and Fuel System Run Up test improvements.• Exhaust Gas Recirculation (EGR) system improvement to help prevent freeze up.• Diesel Exhaust Fluid (DEF) system enhancement during stationary regeneration.
18-115-16 11/03/16	'17 DJ/D2	<p><i>Powertrain Diagnostic and System Improvements Flash/Update</i></p> <p>This bulletin applies to vehicles built on or before October 31, 2016, equipped with a 6.7-liter Cummins diesel engine (Sales Code ETK).</p> <p>A customer may experience one or more of the following conditions:</p> <ul style="list-style-type: none">• Unpleasant odor in the vehicle at low speeds and when regeneration is active.• Intermittent no crank and no start (68RFE automatic transmission only).• Unable to complete "Fuel Pressure Override" test in the scan tool. <p>In addition, the following software enhancements are also available:</p> <ul style="list-style-type: none">• Improved fuel filter reminder calibration.• Improved regeneration at low speeds.• Updated accelerator pedal calibration to reduce hesitation.• Calibration changes to reduce turbo inlet temperatures. <p>This bulletin involves reprogramming the Engine Control Module/Powertrain Control Module (ECM/PCM) with the latest available software.</p>

CATEGORY 18**VEHICLE PERFORMANCE**

<u>TSB#</u>	<u>MODEL</u>	<u>SUBJECT/DESCRIPTION</u>
18-003-17 Rev B 2/21/17	'16 DS	<p><i>Engine Oil Viscosity Upgrade and Flash Enhancements</i></p> <p>The following powertrain system improvements/enhancements are included in this software release:</p> <ul style="list-style-type: none">• Fan calibration.• Transmission calibration.• Revised oil change algorithm. <p>This bulletin involves reprogramming the powertrain control module and the transmission control module. It also involves changing the engine oil with new 5W40 engine oil (Shell Rotella T SW-40 full synthetic motor oil) and applying a sticker to the engine oil filler cap. An addendum card will need to be added in the Owner's Manual.</p>
18-015-17 Rev A 3/10/17	'16 DJ/D2	<p><i>6.7-Liter Diagnostic and System Improvements: Flash Update</i></p> <p>The following diagnostic trouble codes (DTCs) have been changed from a one trip fault to a two trip fault:</p> <p>P0421 – Catalyst 1 Efficiency Below Threshold Bank 1. P2280 – Air Flow Restriction /Leak Between Air Cleaner and MAF. P203C – (Diesel Exhaust Fluid) Reductant Level Sensor Circuit Low. P208D – (Diesel Exhaust Fluid) Reductant Pump Control Circuit High.</p> <p>A small number of customers may experience a Malfunction Indicator Lamp (MIL) illumination. Upon further investigation a technician may find the following DTCs set in the PCM memory:</p> <p>P1451 – Diesel Particulate Filter System Performance. P229E – NOx Sensor Circuit – Bank 1 Sensor 2. P0128 – Thermostat Rationality Improvements. P2281 – Air Leak Between MAF and Throttle Body. P218F – Reductant No flow Detected. P0218 – Transmission High Temperature Operation Activated (68RFE Only). P0868 – Line Pressure Low, MIL Action (68RFE Only). U110E – Lost Ambient Temperature Message. P205E – (Diesel Exhaust Fluid) Reductant Tank Temperature Sensor Circuit Intermittent (setting when the black heater is plugged in).</p> <p>In addition to addressing the above DTCs, the following powertrain system improvements/enhancements are also included in this software release:</p> <ul style="list-style-type: none">• Improvement to correct engine feels like low or reduced power.• Engine Noise Improvements.• Engine Hesitation Improvement.• Improved Engine Fuel Economy.• Reduction in engine noise during regeneration at idle.• 68RFE Transmission Overall Shift Quality Improvements.• Test results fix for partial range misfire (68RFE Only).• Ambient Air Temperature Improvements.• Stationary Desoot with wiTECH Fix.• OBD Misfire Monitoring Improvement (68RFE Only). <p>This bulletin involves reprogramming the Engine Control Module/Powertrain Control Module (ECM/PCM) with the latest available software.</p>

CATEGORY 18**VEHICLE PERFORMANCE****TSB#**18-034-17
4/6/17**MODEL**

'15 DJ/D2

SUBJECT/DESCRIPTION*Diagnostic and System Improvements, Flash Update*

Customers may experience a malfunction indicator lamp (MIL) illumination. Upon further investigation a technician may find one or more of the following DTCs set in the PCM memory:

P1451 – Diesel Particulate Filter System Performance.

P229E – NOx Sensor Circuit - Bank 1 Sensor 2.

P218F – Reductant No Flow Detected.

P242F – Diesel Particulate Filter Restriction - Ash Accumulation

P205E – (Diesel Exhaust Fluid) Reductant Tank Temperature Sensor Circuit Intermittent (setting when the block heater is plugged in).

U110E – Lost Ambient Temperature Message.

P20E8 – (Diesel Exhaust Fluid) Reductant Pressure Too Low.

P2281 – Air Leak Between MAF and Throttle Body.

P1477 – Intake Air Diverter Valve Position Sensor Circuit Shorted To Ground.

U1421 – Implausible Ignition Key Off Time Received.

P026B – Injection Timing Performance

In addition to addressing the above DTCs, the following powertrain system improvements/enhancements are also included in this software release:

- Improved Exhaust Gas Recirculation (EGR) valve response.
- Over Running Clutch (ORC) software improvement.
- Unpleasant odor in the vehicle at low speeds during regeneration cycle.
- Selective Catalytic Reduction (SCR) Efficiency improvement in cold weather.
- Enhanced software for a No crank/No start issue. (U0100 – Lost Communication with ECM/PCM.) (Sales Code DG7)
- Ambient Air Temperature (AAT) improvements.
- 68RFE Transmission overall shift quality improvements.
- Charging system improvements for single alternator applications (changes the cutout threshold from 600 to 500rpm)
- Diesel Exhaust Fluid (DEF) system calibration improvement during Stationary Regeneration.
- Cold idle speed stability improvement.
- Charging system improvements for dual alternator applications.
- Torque increase to 865 ft/lbs (D2 vehicles equipped with the Aisin transmission sales code DF2 only)
- Fuel Filter Minder calibration changes.
- wiTECH Fuel Pressure Override and Fuel System Run Up test improvements.

This bulletin involves reprogramming the Engine control Module/Powertrain Control Module (ECM/PCM) with the latest available software.

CATEGORY 18**VEHICLE PERFORMANCE**

<u>TSB#</u>	<u>MODEL</u>	<u>SUBJECT/DESCRIPTION</u>
18-041-17 5/4/17	'14 DJ/D2	<p><i>Diagnostic and System Improvements, Flash Update</i></p> <p>Customers may experience a malfunction indicator lamp (MIL) illumination. Upon further investigation a technician may find one or more of the following DTCs set in the PCM memory:</p> <p>P2463 – Diesel Particulate Filter - Soot Accumulation. P1451 – Diesel Particulate Filter System Performance. P218F – Reductant No Flow Detected. P242F – Diesel Particulate Filter Restriction - Ash Accumulation P2281 – Air Leak Between MAF and Throttle Body. P205E – (Diesel Exhaust Fluid) Reductant Tank Temperature Sensor Circuit Intermittent (setting when the block heater is plugged in). U110E – Lost Ambient Temperature Message. P20E8 – (Diesel Exhaust Fluid) Reductant Pressure Too Low. P1477 – Intake Air Diverter Valve Position Sensor Circuit Shorted To Ground. U3017 – Control Module Timer/Clock Performance. P0087 – Fuel Rail Pressure Too Low. P0544 – Exhaust Gas Temperature Sensor Circuit-Sensor 1/1 P0128 – Thermostat Rationality. In cold ambient temperatures. P214D – SCR NOx Catalyst Outlet Temperature Too High During Particulate Filter Regeneration. P24A5 – Exhaust Gas Recirculation (EGR) Cooler Bypass Bank 1 Control Stuck. P040B – Exhaust Gas Recirculation Temperature Sensor “A” Circuit Performance. P0420 – Catalyst Efficiency Below Threshold. U1421 – Implausible Ignition Key Off Time Received. P026B – Injection Timing Performance. P04DB – Crankcase Ventilation System Disconnected. P1C55 – NOx Sensor Intermittent - Bank 1 Sensor 1. P202E – Diesel Exhaust Fluid (DEF) Reductant Injector Performance. P20EE – SCR NOx Catalyst Efficiency Below Threshold - Bank 1. P2002 – Diesel Particulate Filter Efficiency Below Threshold. P0604 – Internal Control Module RAM.</p> <p>In addition to the above symptoms, the following software improvements are also included in this update:</p> <p>The following DTCs have been changed from a one trip fault to a two trip fault: P0201-P0206 – Fuel Injector X Circuit Open Fault Codes P049D – EGR Control Position Exceeding Learning Limit P226C – Turbocharger boost control “A” Slow Response</p> <p>The following DTC has been changed from a two trip fault to one trip fault: U1A24 – Lost Communication with Ammonia Sensor</p>

18-041-17
continued

Other software enhancements included:

- Over Running Clutch (ORC) software improvement.
- Unpleasant odor in the vehicle at low speeds during regeneration cycle.
- Selective Catalytic Reduction (SCR) Efficiency improvement in cold weather.
- NOx sensor calibration improvements.
- Cap Urea Dosing at Low Temps.
- Ambient Air Temperature (AAT) improvements.
- SCR efficiency scan tool test improvement.
- 68RFE Transmission shift quality improvements for low speed first to neutral and neutral to first (garage shifts).
- Charging system improvements for single alternator applications (changes the cutout threshold from 600 to 500rpm)
- Diesel Exhaust Fluid (DEF) system calibration improvement during stationary regeneration.
- Cold idle speed stability improvement.
- Fuel Filter Minder calibration improvement to save current mileage count during module reflash.
- Diagnostic improvement for DTC P20E8 - (Diesel Exhaust Fluid) Reductant Pressure Too Low. Increases pump prime attempts to eliminate false failures.
- Cruise control system improvements.
- Improvements in exhaust brake switch operation.
- Charging system improvements for dual alternator applications.
- Cold Idle Stability improvements.
- Charge Air Cooler (CAC) leak detection software improvements.
- Various wiTECH data and system test additions or improvements.
- 68RFE transmission shift quality improvements.
- Dosing thaw calibration improvement.
- I/M OBD II readiness-DTC P2002 improvements help Particulate Matter (PM) filter monitor group to be set to ready more often.
- Grid heater inhibit operation correction.
- Add engine run time to fuel filter minder.
- Dual alternator wiTECH improvements.
- Inducement timer reset procedure improvement.
- DEF refill detection calibration improvement.

If the customer describes the symptom/condition listed above or if the technician finds the DTC, perform the repair procedure which involves reprogramming the ECM/PCM with the latest software update.

CATEGORY 18**VEHICLE PERFORMANCE**

<u>TSB#</u>	<u>MODEL</u>	<u>SUBJECT/DESCRIPTION</u>
18-074-17 8/16/17	'17 DD/DF/DP	<p><i>Powertrain Diagnostic and System Improvements—Flash Update</i></p> <p>Customer may experience a Malfunction Indicator Lamp (MIL) illumination. Upon further investigation the technician may find that the following Diagnostic Trouble Codes (DTCs) have been set:</p> <ul style="list-style-type: none">• P1C55 – NOx Sensor Intermittent – Bank 1 Sensor 1.• P202E – Reductant Injector Performance.• P218F – Reductant No flow Detected. <p>In addition, the following software enhancements are also available:</p> <ul style="list-style-type: none">• Fuel filter minder improvement.• Calibration changes to engine-off timer.• Changes to engine warm up protection.• Hydrocarbon Desorption (HCD) drivability improvements.• A/C pressure sensor update.• Exhaust Gas Recirculation (EGR) calibration changes. <p>This bulletin involves reprogramming the Engine Control Module (ECM)/Powertrain Control Module (PCM) with the latest available software.</p>
18-092-17 11/9/17	'16 DD/DF/DP	<p><i>Flash: 6.7 Diagnostic and System Improvements</i></p> <p>The following Diagnostic Trouble Codes (DTCs) have been changed from a one trip fault to a two trip fault:</p> <ul style="list-style-type: none">P2280 – Air Flow Restriction/Leak Between Air Cleaner And MAF.P203C – (Diesel Exhaust Fluid) Reductant Level Sensor Circuit Low.P208D – (Diesel Exhaust Fluid) Reductant Pump Control Circuit High. <p>Customers may experience a Malfunction Indicator Lamp (MIL) illumination. Upon further investigation a technician may find the following DTCs set in the PCM memory:</p> <ul style="list-style-type: none">P218F – Reductant No Flow DetectedP202E – (Diesel Exhaust Fluid) Reductant Injector Performance (automatic transmission only).U0001-00 – CAN C BUS (automatic transmission only).P1C55 – NOx Sensor Intermittent - Bank 1 Sensor 1 (automatic transmission only).P24A5 – EGR Cooler Bypass Bank 1 Control Stuck (automatic transmission only).P207F – Reductant Quality PerformanceU110E – Lost Ambient Temperature Message. <p>The following improvements/enhancements are also included in this software release:</p> <ul style="list-style-type: none">• Fuel pressure override test improvement for wiTECH (automatic transmission only).• AC pressure sensor error threshold change (automatic transmission only).• No crank, No start fix (automatic transmission only).• Ambient Air Temperature Improvements.• Stationary Desoot with wiTECH Fix.

CATEGORY 18**VEHICLE PERFORMANCE**

<u>TSB#</u>	<u>MODEL</u>	<u>SUBJECT/DESCRIPTION</u>
18-015-17 Rev. B 10/29/17	'16 DJ/D2	<p><i>Flash: 6.7 Diagnostic and System Improvements</i></p> <p>The following Diagnostic Trouble Codes (DTCs) have been changed from a one-trip fault to a two-trip fault:</p> <p>P0421 – Catalyst 1 Efficiency Below Threshold Bank 1. P2280 – Air Flow Restriction/Leak Between Air Cleaner And MAF. P203C – (Diesel Exhaust Fluid) Reductant Level Sensor Circuit Low. P208D – (Diesel Exhaust Fluid) Reductant Pump Control Circuit High.</p>

A small number of customers may experience a Malfunction Indicator Lamp (MIL) illumination. Upon further investigation a technician may find the following DTCs set in the PCM memory:

- P218F – Reductant No Flow Detected
- P202E – (Diesel Exhaust Fluid) Reductant Injector Performance.
- U0001-00 – CAN C BUS.
- P24A5 – EGR Cooler Bypass Bank 1 Control Stuck.
- P1451 – Diesel Particulate Filter System Performance.
- P229E – NOx Sensor Circuit – Bank 1 Sensor 2.
- P0128 – Thermostat Rationality Improvements.
- P2281 – Air Leak Between MAF and Throttle Body.
- P0218 – Transmission High Temperature Operation Activated (68RFE Only).
- P0868 – Line Pressure Low, MIL Action (68RFE Only).
- U110E – Lost Ambient Temperature Message.
- P205E – (Diesel Exhaust Fluid) Reductant Tank Temperature Sensor Circuit Intermittent (setting when the block heater is plugged in).

In addition to addressing the above DTCs, the following powertrain system improvements/enhancements are also included in this software release:

- Fuel pressure override test improvement for wiTECH.
- AC pressure sensor error threshold change.
- No crank, No start fix.
- Improvement to correct engine feels like low or reduced power.
- Engine Noise Improvements.
- Engine Hesitation Improvement.
- Improved Engine Fuel Economy.
- Reduction in engine noise during regeneration at idle.
- 68RFE Transmission Overall Shift Quality Improvements.
- Test results fix for partial range misfire (68RFE Only).
- Ambient Air Temperature Improvements.
- Stationary Desoot with wiTECH Fix.
- OBD Misfire Monitoring Improvement (68RFE Only).

CATEGORY 21**TRANSMISSION AND TRANSFER CASE**

<u>TSB#</u>	<u>MODEL</u>	<u>SUBJECT/DESCRIPTION</u>
21-024-17 6/7/17	'17 D2/DJ	<p><i>Transmission Oil Pan Leaking</i></p> <p>This bulletin applies to vehicles built on or after October 10, 2016, and on or before March 31, 2017, equipped with a 68RFE Transmission (sales code DG7).</p> <p>Some customers or technicians may experience a transmission oil leak. Upon further investigation, a technician may find the transmission oil pan is leaking.</p> <p>This bulletin involves inspecting and if necessary resealing the transmission oil pan.</p>
21-030-17 7/7/17	'16-'17 D2/DD/DP	<p><i>Aisin Transmission – No Reverse, 3rd or 5th Gears</i></p> <p>This bulletin applies to vehicles built on or after March 30, 2016 and on or before October, 2016. A small number of customers may experience a Malfunction Indicator Lamp (MIL) illumination. Upon further investigation the technician may find one or more of the following Diagnostic Trouble Codes (DTCs) set in the Transmission Control Module (TCM) memory:</p> <ul style="list-style-type: none"> • P0733-00 – Gear 3 Shift Incorrect Ratio. • P0736-00 – Gear Ratio Error in Reverse. <p>This bulletin involves replacing the transmission assembly.</p>

CATEGORY 22 TIRES & WHEELS

<u>TSB#</u>	<u>MODEL</u>	<u>SUBJECT/DESCRIPTION</u>
22-003-16 5/19/16	'16 DS	<p><i>Spare Tire Inspection or Replacement</i></p> <p>This bulletin applies to vehicles built on or after April 12, 2016, and on or before April 14, 2016, equipped with the Full size Temporary Use Spare Tire (Sales Code TBS). The customer may notice that the spare tire has a cut in the sidewall, or the spare tire is flat.</p> <p>This bulletin involves inspecting and possibly replacing the spare tire.</p> <p>Editor's note: From the picture shown in the TSB (a slash/cut in the sidewall) and the two days identified in production, one could assume that an employee somewhere in the supply chain made a mistake with a box cutter or was not happy with his/her employer.</p>

CATEGORY 23 BODY

<u>TSB#</u>	<u>MODEL</u>	<u>SUBJECT/DESCRIPTION</u>
23-014-17 REV. A 4/4/17	'16 DJ/DD/D2/DP	<p><i>Cracked Clearance Lamps</i></p> <p>This bulletin applies to vehicles built on or after July 1, 2016, or on or before August 1, 2016, equipped with Clearance Lamps.</p> <p>The vehicle may have been built with cab clearance lamps that may fail prematurely.</p> <p>This bulletin involves replacing the cab clearance lamps.</p>
23-022-17 5/5/17	'16-'17 D2/DD/DJ/DP/DS	<p><i>Front Door Glass Disengages From Mounting Clips</i></p> <p>This bulletin applies to vehicles built on or after February 1, 2016, and on or before February 24, 2017.</p> <p>The customer may notice that either left/right front window has fallen into the door and is not allowing the window to open or close.</p> <p>This bulletin involves replacing the front door glass mounting clips.</p>
23-039-17 9/2/17	'16-'17 D2/DD/DJ/DP/DS	<p><i>Rear Door Fixed Glass Cover is Loose</i></p> <p>This bulletin applies to vehicles built on or before September 1, 2017.</p> <p>The customer may notice the glass cover trim is loose or shows a gap on either of the rear doors. If the customer describes the symptom/condition listed above, perform the repair which involves removing a locator pin from the cover trim.</p>
23-040-17 9/2/17	'16-'17 D2/DD/DJ/DP/DS	<p><i>Gap at Center Stack at the Instrument Panel</i></p> <p>This bulletin applies to vehicles built on or before September 1, 2017.</p> <p>The customer may notice a large gap where the center stack meets the instrument panel. If the customer describes the symptom/condition listed above, perform the repair which involves rework to the center stack to eliminate the gap.</p>

CATEGORY 25**EMISSONS CONTROL**

TSB#	MODEL	SUBJECT/DESCRIPTION												
25-001-17 3/2/17	'13-'17 D2/DJ '11-'17 DD/DP	<p><i>This bulletin provides information regarding the diesel Exhaust Fluid (DEF) vehicle delivery fill guidelines.</i></p> <p>Ram diesel vehicles are equipped with an Electronic Vehicle Information Center (EVIC) that will provide the driver with warning messages displayed by the EVIC and audible chimes informing the driver when it is necessary to refill the DEF tank.</p> <p>The driver will be notified when the level of DEF drops below approximately 2.5 gallons. The first level warning displays the message "5mph Max Speed in XXXX miles, DEF Low, Refill Soon." The mileage counter will then begin to countdown to 0 as the vehicle is driven. The message "5mph Max Speed on Restart, Long Idle, or Refuel" will then be displayed followed by the message "5mph Max Speed Refill DEF." At this point, the vehicle will be reduced to a maximum of 5 mph until the DEF tank is refilled. The Powertrain Control Module (PCM) may also set a Diagnostic Trouble Code (DTC) P203F – Diesel Exhaust Fluid Reductant Level Too Low.</p> <p>Dealers are requested to fill the DEF tank just prior to delivering the vehicle to the owner. Do not prematurely fill the DEF tank. DEF has a limited shelf life based on ambient temperatures and exposure to sunlight. Vehicles that are exposed to high temperatures for lengths of time may have their DEF urea concentration degrade to the point that the DEF will become less effective at reducing NOx levels in the SCR catalyst. If this occurs, the engine control system may illuminate the Malfunction Indicator Lamp (MIL) and set related Diagnostic Trouble Codes (DTC). Refer to the following chart to get a better understanding of DEF shelf life.</p> <p>The following chart provides the approximate shelf life of DEF versus temperature.</p> <table border="1"> <thead> <tr> <th>Constant Ambient Storage Temperature °C (°F)</th> <th>Maximum Shelf Life in Months</th> </tr> </thead> <tbody> <tr> <td>10°C (50°F)</td> <td>36 Months</td> </tr> <tr> <td>25°C (77°F)</td> <td>18 Months</td> </tr> <tr> <td>30°C (86°F)</td> <td>12 Months</td> </tr> <tr> <td>35°C (95°F)</td> <td>6 Months</td> </tr> <tr> <td>40°C (104°F)</td> <td>2 Months</td> </tr> </tbody> </table> <p>If it is suspected that the urea concentration level has decreased too low, DEF can be tested using a Refractometer.</p> <p>The DEF tank has been designed with an air space that accommodates the expansion of DEF. Never 'top-off' the DEF tank after a normal fill, as that will allow DEF to fill the expansion space, which can cause damage to the tank.</p> <p>DEF can crystalize when exposed to air. However, the crystals should re-dissolve when reintroduced to fresh DEF. Crystallization may be noticed around the DEF filler opening and is normal.</p>	Constant Ambient Storage Temperature °C (°F)	Maximum Shelf Life in Months	10°C (50°F)	36 Months	25°C (77°F)	18 Months	30°C (86°F)	12 Months	35°C (95°F)	6 Months	40°C (104°F)	2 Months
Constant Ambient Storage Temperature °C (°F)	Maximum Shelf Life in Months													
10°C (50°F)	36 Months													
25°C (77°F)	18 Months													
30°C (86°F)	12 Months													
35°C (95°F)	6 Months													
40°C (104°F)	2 Months													
25-002-17 3/10/17	'17 DJ/D2/DD/DP	<p><i>Dosing Control Unit Diagnostic and System Improvements: Flash Update</i></p> <p>This bulletin applies to vehicles built on or before February 22, 2017.</p> <p>Some customers may experience a Malfunction Indicator Lamp (MIL) illumination specifically in cold weather. Upon further investigation, a technician may find the following Diagnostic Trouble Code (DTC) P207F – Reductant Quality Performance.</p> <p>This bulletin involves reprogramming the Dosing Control Unit (DCU) with the latest available software.</p>												
25-003-17 3/24/17	'16 D2/ DJ/DD/DP	<p>Flash: Dosing Control Unit (DCU) Diagnostic and System Improvements</p> <p>Some customers may experience a malfunction indicator lamp (MIL) illumination. Upon further investigation, a technician may find the following Diagnostic Trouble Codes (DTCs):</p> <p>P207F – Reductant Quality Performance. P202C – Reductant Tank Heater Control Circuit High. P203B – Reductant Level Sensor 1 Circuit Performance.</p> <p>This bulletin involves reprogramming the DCU with the latest available software and if necessary replacing the unit.</p>												

2017 RECALL NOTICES

RECALLS ISSUED 11/1/2016

EMISSIONS RECALL S47 SELECTIVE CATALYTIC REDUCTION CATALYST

Date: November 2016

Models/Production:

'13 DJ 2500 Series Truck

This recall applies only to the above vehicles equipped with a 6.7-liter diesel engine (sales code ETK) built January 7, 2013 through October 3, 2013.

Subject: Cummins, Inc. has determined that this Emissions Recall is necessary. FCA is assisting with the recall by working with you to facilitate the recall. The Selective Catalytic Reduction (SCR) catalyst may experience degradation. This may cause tailpipe emissions of Oxides of Nitrogen (NOx) to exceed the Environment Emission Standards.

Repair: The SCR catalyst must be replaced with a new SCR catalyst. The ammonia sensor module must also be eliminated.

SAFETY RECALL S58 FRONT SUSPENSION TRACK BAR FRAME BRACKET

Date: September 2016

Models/Production:

'15 D2 3500 Series Truck

'15 DD 3500 Series Cab/Chassis

'15 DJ 2500 Series Truck, excluding Power Wagon models

This recall applies only to the above vehicles built from May 24, 2014 through July 3, 2014.

Subject: The front suspension track bar frame bracket on about 60 of the above vehicles may have been improperly welded to the frame rail during the manufacturing process. The front suspension track bar frame bracket welds may break and allow the front suspension track bar frame bracket to separate from the frame rail. A separated front suspension track bar frame bracket will cause diminished steering response and could cause a crash without warning.

Repair: The front suspension track bar frame brackets must be replaced on all affected vehicles.

RECALLS ISSUED 1/1/2017–2/14/2017 EMISSIONS RECALL S86 SELECTIVE CATALYTIC REDUCTION CATALYST

Date: January 2017

Models/Production:

'13 DJ 2500 Series Truck

This recall applies to vehicles equipped with a 6.7-liter Cummins engine built October 24, 2012 through August 3, 2013.

Subject: It has been determined that this Emissions Recall is necessary, and has been submitted as an Influenced Recall Plan to the California Air Resources Board and the United States Environmental Protection Agency. Under the plan, FCA is assisting by working with you to facilitate the recall. The subject of this recall is that some MY2013 RAM 2500 vehicles may experience deactivation of the selective catalyst reduction (SCR) system. This can cause tailpipe emissions of oxides of nitrogen (NOx) to exceed the emissions standard.

Repair: The repair involves removing the existing SCR catalyst and Ammonia Sensor Module and replacing it with a new SCR catalyst.

SAFETY RECALL S87 SELECTIVE CATALYTIC REDUCTION CATALYST

Date: January 2017

Models/Production:

'14-'15 DJ 2500 Series Truck

This recall applies to vehicles equipped with a 6.7-liter Cummins engine built June 4, 2013 through July 10, 2015.

Subject: It has been determined that this Emissions Recall is necessary, and has been submitted as an Influenced Recall Plan to the California Air Resources Board and the United States Environmental Protection Agency. Under the plan, FCA is assisting by working with you to facilitate the recall. Some 2014 and 2015 model year RAM 2500 trucks may experience deactivation of the selective catalyst reduction (SCR) system. Degradation of the SCR system can cause tailpipe emissions of oxides of nitrogen (NOx) to exceed the emissions standard.

Repair: The repair involves removing the existing SCR catalyst and Ammonia Sensor Module and replacing both with a new SCR catalyst.

**RECALLS ISSUED 3/1/2017
CUSTOMER SATISFACTION NOTIFICATION T13
MANUAL TRANSMISSION SHIFT LEVER**

Date: March 2017

Models/Production:

'15-'16 DD 3500 Cab Chassis
'15-'16 DJ 2500 Pickup
'15-'16 DP 4500/5500 Cab Chassis
'15-'16 D2 3500 Pickup

This campaign applies only to the above vehicles equipped with a six-speed manual transmission built from February 3, 2015, through November 30, 2015.

Subject: The manual transmission shift lever rubber insert on about 4,300 vehicles may not have properly adhered to the metal shifter housing during the shifter manufacturing process. This condition could cause looseness in the gear shift lever, noise, and additional effort to move the shifter into the selected gear.

Repair: The manual transmission shift lever must be replaced on all involved vehicles.

**RECALLS ISSUED IN 2017 THIRD QUARTER
EMISSIONS RECALL T05
SELECTIVE CATALYTIC REDUCTION CATALYST**

Date: July 2017

Models/Production:

'13-'14 D2 Ram 3500 Pickup

2015 MY vehicles will be added to this campaign at a later date.

Subject: It has been determined that this Emissions Recall is necessary, and has been submitted to the California Air Resources Board and the United States Environmental Protection Agency. Under the plan, FCA is assisting by working with you to facilitate the recall. The subject of this recall is that some MY2013 through 2014 Ram 3500 vehicles may experience deactivation of the selective catalyst reduction (SCR) system. This can cause tailpipe emissions of oxides of nitrogen (NOx) to exceed the emissions standard.

Repair: The repair involves removing the existing SCR catalyst and Ammonia Sensor Module and replacing both with new SCR catalyst.

**SAFETY RECALL T25
OCCUPANT RESTRAINT CONTROL MODULE**

Date: March 2017

Models/Production:

'13-'16 DS 1500 Pickup
'13-'16 DJ 2500 Pickup
'14-'16 D2 3500 Pickup

This recall applies only to the above vehicles equipped with roll rate sensing built from June 8, 2012 through July 10, 2015.

Subject: The Occupant Restraint Control (ORC) module on about 1,030,000 of the above vehicles may activate a diagnostic trouble code (DTC) due to external stimulus which disables its ability to sense vehicle rollover events. When the DTC is set, airbag and seat belt pretensioner deployment based on rollover sensing is disabled for the ignition cycle in which the DTC was set. The loss of air bag and seat belt pretensioner deployment capability during a crash may increase the risk of injury or death.

Repair: The ORC module on involved vehicles must be reprogrammed with new software.

MOST COMMON PROBLEMS

The “Most Common Problems” title is certain to catch your attention. Rightfully so, we chose the brazen title to serve a purpose.

As a prospective owner or as the new owner of a used Turbo Diesel you need to be aware of the problems that are inherent with the truck you are considering or have recently purchased. Although some will dwell on the problems, the majority of TDR owners take initiative to solve/correct, anticipate/prepare for a future situation. That’s what the TDR is all about! And, thanks to the support from Chrysler and Cummins, we are equipped with answers and solutions rather than wonderment and isolation that would exist without a support group.

With the introduction out of the way, I resourced three important TDR articles:

“Favorite Fumbles—Fabulous Fixes” looks at problems that we’ve seen in the many years of the TDR magazine and web site.

“12-Valve Dowel Pin Solution” gives a discussion and solution to the problem that can happen to a ‘89-‘98 12-valve engine.

“Fuel Transfer Pumps Revisited” talks about the low pressure fuel system for all year model trucks and then gives specific repair techniques for the vintage year truck you may own. This is a must-read for anyone with a ‘98.5-‘02 model year Turbo Diesel.

We hope you find “Most Common Problems” to be helpful in your evaluation of the Dodge/Cummins Turbo Diesel pickup.

Favorite Fumbles—Fabulous Fixes

G. R. Whale and Jim Anderson

Everyone knows the automakers have proving grounds where, rather obviously, part of the process is to prove things work. In theory, any part the customer can break can be broken under controlled circumstances at the proving grounds.

However, customers routinely outnumber proving ground personnel. At some western desert testing centers the typical daily on-site staff amounts to 25-50 people, and if you put each in a car and spread them out on the “big” oval track, there’d still be a quarter of a mile of space between the cars. The reptiles outnumber humans exponentially and they don’t drive—does that tell you anything?

So things go wrong with vehicles. And without debating what might cause the TDR readership to be so adept at it (or Dodge for the lack of satisfactory “proving”), the readers do find many things that go wrong. And then they figure out how to fix them.

When the first Dodge/Cummins arrived in 1989, it had more than a few things going for it. Apart from the engine and transmission, not too much of it was new . . . heck, a lot of it could be traced to the early 1970s. So, again in theory, the only “new” problems would be limited to the engine or some part of the driveline, wiring, or cooling system attached to it.

So let’s begin our discussion with problems that can be associated with Dodge/Cummins pickups, in First, Second, and Third Generation order, and randomly chosen by TDR writers Whale and Anderson. Some are more infamous than others, as it is with customers.

ACROSS THE BOARD

Glitch: My steering’s sloppy or the tires are cupping.

Fix: This one can oft be traced beyond pilot error, although we’re certainly not ruling that out. It tends to be more of an issue on 4WD trucks, and newer models have fewer problems. A Borgeson steering shaft helps on almost any truck, and First Generation four-wheel drives often benefit from an adjustable drag link; a mild drop-pitman arm; or on really heavy front ends, an upgrade or replacement of the upper kingpin bushing—a much simpler job than it sounds. Two-wheel-drive versions benefit from a set of Moog ball joints. Later model 4WDs tend to wear out trackbars, and Luke’s Link appears to have the fix for that one.

In some First Generation trucks the steering box broke off the frame rail, or the box moved on the frame from elongated bolt holes. Like many ‘70s vintage GM 4x4s, adding a brace from the opposite side frame rail fixed it, but unlike the GMs, the aftermarket did not develop a kit for it.

Worn axle U-joints (4x4 only) along with other worn front end parts could cause a phenomenon known among Dodge diesel owners as a “death wobble” that was set up by crossing a seam in the road that ran at an angle to the direction of travel. Cure: inspect/ replace any loose or worn front end component including wheel bearings, front axle U-joints, hubs, tie-rod ends, pitman arms, steering boxes, ball joints, steering stabilizer, track bar, etc. The cumulative slop of all the above components leads to the “death wobble”.

Ref: I 33, p 41; I 35, p 13; I46, p 20

Glitch: My truck's dripping oil.

Fix: Not until many years into the Dodge/Cummins partnership did the engine have PCV...it was positively vented straight overboard. Occasionally some oil would find its way into the blow-by tube, and eventually drip out the bottom. When Second Generation trucks came out, this problem also resulted in a lot of erroneous front differential yoke seal replacements because the engine oil (not differential fluid) dripped down in the same area. Of course, if Dodge hadn't moved the differential from the right side to the wrong side, this problem wouldn't have existed. Most people simply put a small bottle with some holes in the side on the bottom of the vent tube—it could still “breathe” but the oil was trapped in the bottle. Dodge did this for 2001 but most oil change locations forget to empty it, and when it fills the fan blows oil all over the place.

On 24-valve engines the breather moved to the front...and any truck on a steep descent could lose a lot of engine oil as crankcase pressure pushed it out the tube. Cummins offers a fix that moves the breather inlet back alongside the engine where it is less affected by crankcase oil level on steep grades—right where it was on 12-valve engines (Dodge TSB 09-002-02, Crankcase Breather Overflow: I38, page 84).

Ref: I 24, p 17

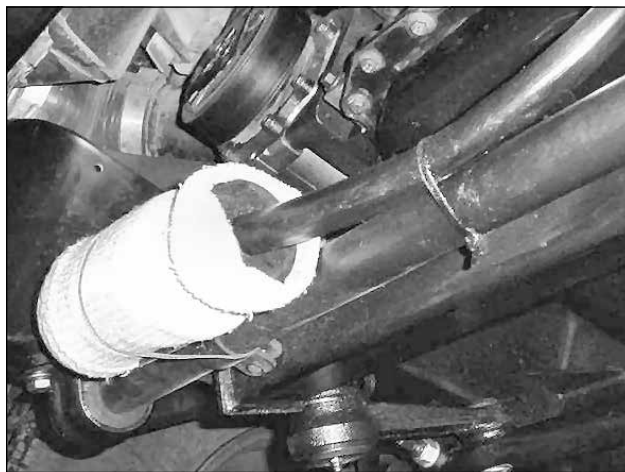

The old cotton sock idea is an easy fix with no drips or oily film on anything but the outer sock. I replace the sock while I am under the truck changing oil. I extended the tube and drip catch bottle down to the anti-sway bar and secured it with a couple of wire ties.
Gary-K7GLD, Canyon City, OR

Glitch: My truck smells like a refinery.

Owners of 24-valve trucks reported a “heavy oil smell” coming into the truck cab, caused by the crankcase breather tube venting the smell (particularly after an oil change) into the air stream of the engine fan, especially when sitting at a stoplight with the heater or air conditioner running and the cab fan on. The vent fan sucked the smell into the cab air intake at the windshield base.

Fix: Extend the crankcase breather outlet toward the rear of the engine out of the engine fan air stream. Dodge offers an engine oil that lacks the aromatic compounds that cause the objectionable smell.

Other ways to cure the heavy oil smell are to drive the truck only in warm weather and to use used lube oil when you do an oil change.

Say what?

During the winter months the air is colder and the diesel exhaust fumes and oil breather fumes hang low to the ground. Thus, an explanation for the noticeable smell in the winter months.

But, used oil? Seriously there is a Dodge technical service bulletin (TSB 09-02-00; I34, page 99) that addresses the heavy oil smell. The odor condition is a result of certain diesel oil additives and the odor reduces in intensity as the oil ages. The aging process typically takes place in 250 to 750 miles after the oil change. Used oil anyone?

Glitch: The truck started, but the starter won't stop.

Fix: Worn and pitted starter solenoid contacts will cause the truck not to start, or the starter won't disengage after the engine fires. A heavy duty contact kit is available from Larry B (I 49, p 154) to fix the problem.

Glitch: Gauges don't work.

Fix: The cause is most often a poor ground between the dashboard and the body, chassis, and engine. Run new ground straps from the dashboard frame to the body, from the body to the frame, and from the frame to the engine. This can affect all diesel Rams. A secondary cause on '99 to '02 trucks is a faulty connection between the dash display driver cable and the PCM.

Glitch: Gauges do work, but the fuel reading is inaccurate.

On '89 to '02 trucks the Dodge-only fuel tank sending unit fails, either by becoming stuck at a certain fuel level or by reading low level at all times.

Fix: The only solution is to drop the fuel tank and replace the sender. The barrel strainer the level sender attaches to may also develop a glitch where it doesn't move up and down with fuel level, thus leading to erroneous level readings. Replace the barrel strainer.

Ref: I 49, p 148

Glitch: My clutch won't release.

Fix: This may happen to any Dodge diesel. If the clutch fails to release upon stopping the truck, either the clutch master/slave cylinder circuit has failed, thus requiring replacement; or the pilot bearing in the flywheel, which captures the nose of the transmission input shaft, has failed, allowing the input shaft to be deflected sideways when the clutch pedal is pushed, which binds the clutch as it slides on the input shaft splines. Pilot bearing replacement is necessary, along with replacement of the transmission input shaft if the nose of the shaft is not perfectly round or is scored. While the Dodge input shaft is priced at over \$500, the shaft can be bought in the same box with similar part numbers from other sources for about \$100. Damage to both components can be avoided by using the clutch only for gear changes, and not sitting with your foot on it.

Ref: I50, p 36; I49, p 10; I36, p 75

Glitch: Driveline vibration based on road speed.

Fix: It sounds like a worn out driveshaft universal joint or unbalanced shaft, but may also be caused by a bad carrier bearing or bearing support in a two-piece driveshaft system. The bearing cannot be re-lubricated by the owner, and the entire sealed carrier bearing assembly must be replaced. This is presently a Dodge-only part. A heavy load in the lower gears will cause driveline windup as well, leading to vibration that lessens with road speed or less torque applied to the axle. On Third Generation trucks, the driveline alignment should be checked as well.

FIRST GENERATION

Glitch: The front driveshaft on First Generation trucks falls out.

Fix: With the newfound massive torque, slipping front wheels that quickly found traction inevitably made the engine jump out of its mounts or snapped the little Spicer 1310-series front u-joint. A rebuilt driveshaft with a 1350 u-joint solves the problem, and owners with a lifted truck are cautioned to check the Cardan joint cage clearance at the back of this driveshaft.

Glitch: My windshield squeaks.

Fix: All trucks squeak, but this problem applies only to First Generation trucks and involves the bodywork cracking—more literally breaking apart—at the cowl near the lower corners of the windshield. TSB 23-63-94 showed the parts (steel stampings) and procedure for repairing the problem. The adhesive mentioned in the TSB has been discontinued and 3M Panel Bonding Adhesive recommended as the substitute.

Ref: I 33, p 41

Glitch: My automatic is too automated.

Fix: If your automatic transmission truck changes its mind a lot about what gear to use, don't start with the gearbox, but check the throttle position sensor. The letters TPS are as well known to readers, as this infamous part could be a major nuisance. The TPS failure is characterized by a 100-200 rpm swing as the torque converter clutch locks and unlocks repeatedly while the transmission remains in 4th (overdrive) gear. Clean it and the connectors yourself or get a new one; chances are if it hasn't gone bad, it will.

Do not confuse a TPS failure with a TTS (Transmission Temperature Sensor) failure, which is characterized by a 200-400 rpm swing as the transmission cycles between 3rd and 4th gear. Replace the TTS and check the connectors for corrosion. The downshift is made when the failed TTS sensor says the outside temp is below -5° (zero volts). The upshift is made when the TTS again sends a signal (+1 to +5 volts) to the PCM saying the outside temp suddenly climbed to ambient temp, thus allowing overdrive to be engaged.

Ref: I 37, p 46

Glitch: '89-'91.5 truck runs hot.

Fix: This version of the engine was turbocharged, but not intercooled, and long uphill climbs at full throttle caused the engine to overheat due to hot turbocharged air, particularly if the fueling had been turned up for more power. Members routed a fresh air duct from the front of the truck to the turbocharger area to cool the turbo, thus cutting the heat load on the engine, and the aftermarket developed intercoolers that usually came with a new grille for clearance.

Another solution to the '89 to '91 run hot problem was the retrofit of the larger radiator and fan used in the '91.5 to '93 trucks. Way back in Issue 6 TDR member Bruce Burney presented four pages of step-by-step instructions as well as a detailed parts list (approximately \$750 in 1991) to do the conversion. From pictures in our archives the '91.5/'93 radiator looks to be about half-again as large. Should a member need a reprint, we will be happy to fax the article to him.

SECOND GENERATION

Glitch: My gearbox is a nut short.

Fix: One of the most infamous flaws in Second Generation trucks with the NV4500 gearbox was the mainshaft nut backing off and making fifth gear useless or gone altogether. TSB 21-10-98 Rev A from 9/25/98 addresses this issue in 13 pages of detail. The replacement nut has a set screw to lock it in place, after you've installed thread locker and torqued it to 350 ft-lbs. The Dodge fix didn't always work, since the original nut was cheaply made. Sometimes a new gear was needed due to internal gear spline wear, or a new transmission output rear shaft was needed due to external spline wear. Sometimes the Dodge revised nut didn't work, but the similar-appearing Standard Transmission and Gear nut did. Welding the nut onto the shaft didn't work, as it crystallized the surface steel on the shaft and it later broke at the weld point. There was no Dodge recall on this problem. An avoidance tactic on 12-valve engines is to downshift from 5th to 4th gear when at full throttle at a minimum of 1,800 RPM to avoid excessive torque and engine vibration that causes the nut to loosen. And remember to use GL-4 lubricant as called for by New Venture Gear and your manual.

Ref: I 24, p 27; I 46, p 17

Glitch: The headlights don't work anymore.

Fix: A problem common to many versions, this is usually caused by running too many trailer lights. The parking circuit in your light switch was never designed to run 40 clearance lamps on the trailer and it failed in protest. Replacing the light switch does not solve the problem, but adding a relay to take all the added load does. If you use a camper or pull a trailer, you might consider adding a "ground switch" to the rear lights on your truck, so that they do not reflect in your mirrors when backing up or when the camper is onboard.

In late 2001 there was a recall issued for '94 to '96 model year trucks covering problems associated with the ignition circuit and the truck's blower motor. This important recall information follows:

Ignition Switch Wiring Recall 875

The ignition switch and/or steering column wiring on about 710,000 of the above vehicles may overheat when the blower motor is operated at high speed for an extended period of time. This can cause stalling, loss of blower motor or power window operation, ABS and airbag lamp illumination or a steering column/instrument panel fire.

The vehicles involved in the recall have a vehicle identification number as follows:

Warren ("S" in the 11th VIN position) through April 4, 1996;

St. Louis ("J" in the 11th VIN position) through March 23, 1996

Lago Alberto ("M" in the 11th VIN position) through April 14, 1996;

Salttillo ("G" in the 11th VIN position) through April 14, 1996.

The repair involves installing a blower motor relay and overlay harness to remove the blower motor circuit from the ignition switch. In addition, the ignition switch and electrical connector must be inspected for damage and replaced if necessary.

Note to the membership: the primary parts package for this repair *does not* include a replacement ignition switch assembly, but rather provides a blower motor relay and overlay harness; if necessary, an ignition switch wiring pigtail; clips, screws, washers, etc., to install the blower motor relay.

During the repair the ignition switch and associated connectors are to be inspected. The technician is instructed to look for indications of melting or deformation, specifically at terminals four and five. Very few vehicles are expected to require ignition switch replacement.

Editor's note: *The title of the recall, "Ignition Switch Recall 875" leads one to conclude that the recall is to replace the ignition switch assembly. As summarized from the dealer service instructions, the recall has very little to do with the ignition switch, but rather is focused on adding a relay to the blower motor circuit. The moral of the story—don't jump to conclusions based on the title of a memo and be sure additional trailer light wiring and accessories that are added to your vehicle are on a separate relay-switched circuit.*

Ref: I 30, p 50

Glitch: Go with no throttle.

Fix: With all the racing antics and double-clutching gear jammers, it's no wonder the throttle cable on '94-'96 trucks tended to wear out. It might be the worn spring, ball joints, or the cable itself, but a lot of TDR owners had trouble getting the throttle response desired. This became Safety Recall 970 (part # CANZ9700).

Ref: I 34, p 44

If your truck has throttle but low power/excessive smoke, it's quite possible that one or more of the rubber boots connecting the turbocharger and intercooler piping has slipped under its clamp, allowing your turbocharger's pressurized air to leak. Properly replace the boot under the clamp, retighten the clamp and inspect the rest of the rubber boots of the system for holes in boots or slipping under clamps to restore full manifold boost pressure.

Glitch: Can you say diet?

Fix: No recall, service bulletin or advisory has ever been published on this subject, but some Ram owners found that the seat cushion collapses and the problem is common to all Second Generation trucks. Repair options include an aftermarket seat or new replacement seat, both of which may cost as much as the truck's Blue Book value at this point; a local reupholstery shop; or since the seats have springs at the bottom, a home-made remedy of restuffing for a few bucks. Alternate fixes include new shock absorbers, more weight in the bed, or cutting back the calories.

Ref: I 35, p 14

Glitch: It's very hard to stop. No 4WD. HVAC acting weird. (vintage '94-'96 trucks)

Fix: So what? To paraphrase the immortal words of Commendatore Fanfani, anybody can make a car go slow, don't bother me with details about brakes. Any time the brakes and HVAC act strangely simultaneously, suspect the vacuum source. Typically the problem occurs where the hose connects to the 4WD shift collar. Of course your engine doesn't draw a vacuum but a pump generates it to power some brake boosters, most HVAC systems (which default to Defrost as a safety issue) and on Second Generation and later 4WD models, the front axle disconnect system. The vacuum hose is cheap and easy to find, regardless of the size.

Ref: I 39, p 40

Glitch: ATF drools.

Fix: Although a number of things could be to blame, the first place to look was always the plastic fittings on the transmission fluid cooler lines on '94-'96 trucks. Sooner or later, these got brittle from being overheated and expired, allowing the transmission to pump its fluid all over the road. The fix involves changing the plastic line retainers to Weatherhead fittings; Dodge also offered an upgraded set of lines with metal clips.

On '94-'98 models the transmission lines crossed on the bellhousing. At the cross point, the metal lines rubbed together and wore a hole in one line thus causing loss of all ATF fluid. After replacing the lines, owners installed rubber hose over the lines to keep them apart and prevent vibration rubbing.

Ref: I 17, p 30; I 21, p 39; I 35, p 45

Glitch: My truck's dripping . . . fuel this time, and it's hard to start.

Fix: Fuel out often means air in, and most diesels will be hard, if not impossible, to start with air in the fuel lines. The hoses around the lift pump, mostly on P7100 trucks, degrade over time and develop leaks. And the clamps used tend to distort and often lead to their own leaks; better to get some screw-type band clamps when you do the job.

Ref: I 24, p 19; I 46, p 26

Glitch: Engine quits, tach drops to "0."

Fix: When your diesel behaves like a gas engine with broken points, it's often a bad crankshaft position or camshaft position sensor. Depending on the year, it may also be characterized by the alternator, cruise control, air conditioner compressor not working properly; failure of the automatic transmission to engage overdrive; or failure of the lockup clutch to operate. The crankshaft position sensor is located on the front of the engine immediately above the crankshaft pulley on 12-valve engines or behind the starter on 24-valve engines. Without a cam or crankshaft position signal going to the PCM, the above features won't operate. Replacement of the sensor restores operation. This is a Cummins part, not a Dodge part.

Glitch: Shut-down solenoid is shut down.

Fix: The fuel shutdown solenoid on '94-'98 12-valve trucks has caused its fair share of difficulties, leaving trucks that won't start, won't stay running, or won't shut off. In some cases a "manual" approach to fixing it (much like tapping an old starter solenoid with a mallet), might get you home. An alternate method is to delete the start/run solenoid and replace it with a cab controlled cable to move the fuel shutdown arm. This also makes a fine theft deterrent for the vehicle. Adjustments and replacements are do-it-yourself operations.

Ref: I 46, p 32 (adjust) Re: start/run solenoid.; I 41, p 38; I 48, p 98

Glitch: Manual transmissions fluid specials.

Fix: The five-speed and six-speed New Venture Gear (NV series) manual transmissions both specify a lubricant that is not available at retail locations in quart quantities. Suitable substitutes have been discovered by TDR members that include: 80W-90 synthetic GL-4 gear oil from Amsoil and Red Line for five-speed transmissions, and Pennzoil synthetic 75W-90 gear oil for six-speed manual transmissions at much lower cost than the Mopar lubricant from the Dodge dealer. Use of the wrong lube in either transmission will result in poor shifting and increased wear.

Ref: I 37, p 104

Glitch: The dreaded dowel pin drop.

Fix: A potential problem for '94-'98 12-valve trucks and some '99 trucks is the dowel pin used to locate the aluminum timing gear cover on the front of the engine. When this cheap part falls out, expensive things happen, and it's shown some proclivity for falling out. Cummins says the number of problem engines has been very small, but has revised the part. There are a number of preventative measures, some of which can be done with hand tools. When replacing the dowel pin, replace the crankshaft oil seal and vice versa due to a seal

leak. The fix involves staking the pin, covering the pin with a teardrop-shaped washer placed under a nearby bolt, or removing the pin altogether since it has already served its purpose in locating the housing during engine assembly.

Ref: I 40, p 56 and p 148



A close-up picture of the dowel pin.



A picture showing an egg-shaped washer that covers the dowel pin.

Glitch: No cruise control . . . crankshaft position sensor okay.

Fix: On '89 to '98.5 12-valve trucks the cruise control can become inoperative due to battery acid corrosion from the driver side battery. Replace the control unit after cleaning the area with a baking soda/water solution to neutralize spilled battery acid. Also inspect the battery tray above the solenoids for corrosion damage and repair as necessary.

Glitch: Low power output on 24-valve engines.

Fix: Clean/replace the MAP (Manifold Absolute Pressure) sensor and/or the AIT (Air Intake Temperature) sensor to restore power that is caused by false readings from these dirty sensors. Dirty sensor tips or poor electrical connections at ostensibly weatherproof plugs render the sensors inoperative, which causes restrictions in fueling.

Glitch: '94-'98 12-valve, P-7100 engine specific problems.

Fix: The fuel return line rubber portion on the underside of the intake manifold, in the area of the fuel filter boss, tended to fail due to engine heat and to air getting into the fuel

system. Replacing the hose with a better quality hose that is diesel fuel rated and more heat resistant is the solution.

Low fuel system pressure that causes low power and stalling at hot idle, especially in automatic transmission trucks, may not necessarily signal a failing lift pump. It can also be caused by a failing fuel overflow valve that bypasses too much fuel through the injection pump.

Low power and smoke complaints point to intercooler piping that may not be tight. Additionally, the fuel heater/pre-strainer is probably clogged. This strainer is used only on the Dodge application. The nylon pre-strainer clogs with trash, restricting fuel flow to the lift pump and injection pump. Clean pre-strainer by unscrewing the bottom of the unit, or replace it if damaged.

Another 12-valve specific problem: the quad ring on pre-strainer bowl is cut or distorted. Dodge offers a kit that consists of a new strainer and a new quad ring (O-ring with squared edges) for the strainer bottom assembly for about \$32. The strainer seldom fails. A new quad ring is available at most rubber supply and larger auto supply stores for a buck or two.

Ref: These problems with the 12-valve low pressure fuel system were covered in detail in Issue 49, pages 148-152.

THIRD GENERATION

Glitch: Third Generation performance and fuel issues.

The lift pump located in the area of the fuel filter is being upgraded/replaced by Dodge dealers with the in-tank fuel lift pump as used on the '05 trucks when failure on earlier models is reported during the warranty period.

Fix: If your Third Generation truck is hard to start or offers limited output, check the CP-3 high pressure fuel pump that feeds fuel at 23,000 PSI to the fuel manifold. Failure of the high pressure fuel pump is cured by pump replacement. You should also check the voltage at the electric in-tank fuel pump. There is no TSB on either of these at this time.

Glitch: Excess truck washing due to fuel spills.

Fix: Fuel can spill on the painted fender surface from fuel overflow during the tank filling process on some Third Generation trucks. Drill a small hole in the plastic piece surrounding the fuel filler opening below the fill tube opening to allow any fuel overflow to drain out rather than run down the painted side of your truck.

**G.R. Whale
Jim Anderson
TDR Writers**

12-Valve Dowel Pin Common-Sensical Solution

Always on the lookout for a better way to accomplish a task, the folks at TST products have developed a common-sensical (is that a word?) method to correct the dowel pin problem that many owners have seen with their 12-valve engines. Before I present their solution, let's provide a brief history of the problem.

The dowel pin has been (starting with production in 1983), and continues to be, used on the Cummins B-series engine as a locating and alignment point for the attachment of the front gear cover to the engine block. The problem that has been encountered by owners is predominately with the '94 to '98 12-valve engines. The dowel pin is not a problem on 24-valve engines as the timing cover was changed to fit the 24-valve's VP44 fuel pump. These 12-valve engines have the heavier Bosch P7100 fuel pump which was required for higher horsepower ratings and for the higher injection pressures needed to meet stricter emission legislation enacted 1/1/1994.

The belief is that the vibrations and weight of the P7100 fuel pump cause the dowel pin to loosen in its bore and possibly fall out. If the dowel pin does fall, it can be caught in the fuel pump gear causing a major problem (cracked cam nose):

or it can fall between the cam gear and the front housing and, in its path to the bottom of the oil pan, crack the gear case housing. I've heard many a story of how the cracked housing has been fixed using J-B Weld epoxy. Alternately, the gear housing can be removed and replaced, but this is a big task as the engine's camshaft has to be removed to remove/replace the housing. A final fall-out scenario, the pin falls to the bottom of the oil pan and resides in the bottom of the pan forever (or at least until the pan is removed). There is a screen on the oil pickup tube that prevents the pin from moving into anywhere other than the bottom of the oil pan.

The TST Solution

Several methods of securing the pin into its bore have been developed by shops that service B-series engines. These methods have been covered in previous TDR magazines (Issue 38, page 136; Issue 33, page 46). Additionally, there is a thread on the TDR web site that takes you through the "how-to" should one wish to use the drill/jig method. However, on a recent visit to TST's shop outside Columbus, Indiana, I discovered yet another way to perform this preventive maintenance type procedure.



For those not familiar with the dowel pin the arrow shows its location.



A close-up picture of the dowel pin.



Above is a picture of an egg-shaped washer that is their solution to the problem.

Again, many methods of dowel pin preventive maintenance have been previously discussed. Using some TST shop short-cuts, and the TST developed egg-washer, the task of dowel pin correction has been reduced from highly involved to a job that can be tackled by the shadetree mechanic. A

brief descriptive of the steps involved (again, shadetree-type work as it is simply parts removal and installation) and a few key pictures will take you through the major steps. TST has a comprehensive set of instructions, an egg-washer, with a longer gear cover bolt, a Cummins crankcase seal, a tube of gasket maker (RTV) for the front cover. The price for the kit is \$48. As a note, TST suggests that you consider a replacement fan belt (it's time to change the belt and keep the old one for a spare) and replacement hoses (time to change these too). You'll find other vendors offer these replacement parts.

The TST shop guys have this project down to a two hour science. Lots of removals are necessary, but the repair is simple in scope.

- 1) Drain and remove the coolant overflow tank.
- 2) Drain and remove, or push to the side, the windshield washer tank.
- 3) Remove 10mm bolts (4) and clips that hold the fan shroud in place. The fan shroud will later be removed with the fan in step 7.
- 4) Remove engine accessory drive belt using your 3/8" ratchet in the belt tensioner access socket.
- 5) Cut a piece of cardboard big enough to cover the engine-side of the radiator. Tape the cardboard into place.
- 6) Locate the 10mm bolts (4) for the fan support bracket. Remove the three (#1, #2, #3) easy-to-access bolts. The last bolt (#4) can only be removed with an open end wrench. Support the fan assembly with one hand and loosen the bolt with the other, making sure not to damage the radiator fins.



- 7) CAREFULLY work the fan and the fan shroud out together. This takes time, so go slow. Working with a friend helps. Make sure not to DAMAGE the radiator cooling fins or any hoses that may be in the way.

- 8) Remove the engine oil fill tube located at the front upper side of the gear case. To do this, remove the one 16mm bolt from the bracket to the cylinder head, and loosen the 8mm bolt that clamps the bracket to the oil fill tube. Now rotate the bracket out of the way, and with the use of a large pair of pliers rotate the assembly counter-clockwise to remove it from the gear case cover.
- 9) Remove the two 13mm nuts from the engine speed sensor (RPM pick up). Make sure to make note the orientation of the bracket and the placement of the wire hold-down bracket. Place the sensor off to the side, making sure not to damage the sensor or the wires to the sensor.
- 10) Remove the engine vibration damper using a 15mm socket and 1/2 inch drive breaker bar.
- 11) Using a 10mm socket, remove all the gear cover bolts. Two of these bolts are 8mm and it is best to use a wrench, as these bolts are for the engine speed sensor. Note there are long and short bolts; they will need to be put in the proper locations when reinstalled. Remove the gear cover.
- 12) Locate the dowel pin and look to see if it is fully seated. Most of the pins will be flush with the gear housing or just below flush if they have not backed out. If the pin seems to be backed out find a small punch. With a hammer and punch tap on the head of the dowel pin and drive it into the block as far as possible.



- 13) Lucky step 13! Time to install the special egg-washer, preventive maintenance part. Locate the 10mm bolt next to the dowel pin and remove it, reinstall the longer bolt using the special washer supplied in the kit. This washer will prevent the dowel pin from backing out. Apply loctite high strength (red) thread locker to the threads and torque the bolt to 18 ft. lbs. torque.
- 14) Using a gasket scraper, clean the gear housing gasket surface and the gear housing cover.

- 15) Remove the crankshaft oil seal from the gear cover using a punch or seal driver. Located in the kit is a new crankshaft seal, seal driver, crankshaft seal starter and a dust shield. Install the new crankshaft seal in the gear housing cover applying loctite to the outside of the seal. Using the seal driver, install the new seal in the gear housing cover making sure it is square in the opening. Clean all oil residues from the gear housing cover and gear housing gasket surface and any old gasket material. Apply a light coating of RTV or an oil resistant weather trim adhesive to the gasket surface area of the gear housing cover and place the new gasket on in the proper orientation. Clean all oil off the front of the crankshaft. The new Teflon seal must be installed on a clean dry surface. Using the crankshaft seal starter in the new seal, place the gear housing onto the front of the engine, push the gear housing cover over the crankshaft nose, and remove the seal starter from the crankshaft. Start a couple of bolts to hold cover in place.
- 16) Reinstall the gear cover bolts and torque to 18 ft. lbs.
- 17) Reinstall the four (15mm) engine dampener bolts and torque bolts to 92 ft. lbs.
- 18) Reinstall the engine speed sensor. Set the sensor-to-vibration damper air gap to 0.49 in. minimum to 0.51 in. maximum. Make sure that the two notches in the damper aren't under the sensor when setting the air gap, tighten and torque the mounting nuts to 18 ft. lbs. and remove the feeler gauge.
- 19) Reinstall the fan and fan support bracket along with the fan shroud. The torque value for the four 10mm fan shroud bolts is 18 ft. lbs. Once the fan is in place the fan shroud can be installed. Again, it is nice to have assistance as you carefully lower the fan/fan support into place.
- 20) Reinstall the windshield washer tank to the fan shroud.
- 21) Reinstall the engine accessory drive belt according to the diagram on the front radiator support of your truck.
- 22) Check around the engine compartment and make sure all tools and equipment are clear of any moving parts and test start the engine. Check for any oil leaks and to make sure the engine drive belt is running straight. Correct any oil leaks or drive belt problems before driving the truck.

Thanks to the folks at TST for allowing us to take excerpts from their detailed installation instructions.

Scott Kilby
TST Products
(812) 342-6741

Robert Patton
TDR Staff

JANUARY 2012 POSTSCRIPT – 12-VALVE DOWEL PIN PROBLEM AND ADDITIONAL ITEMS TO CHECK

Before my role as the TDR's editor, years 1987-1996, I was a product support manager for the B-series engine at the Cummins distributor in Atlanta, Georgia. Before the 1994 year model Turbo Diesel truck, the Dodge engine's used a Bosch VE fuel injection pump. As was mentioned in the preceding article, it was thought that the dowel pin problem was restricted to the '94-'98 trucks with the heavier Bosch P7100 fuel injection pump.

In my many years with Cummins prior to 1994 I can say that the dowel pin was not a problem. However, precautionary TDR members with '89-'93 model year trucks have checked the dowel pin and found it to be loose. So, this postscript is a notice to the '89-'93 owners to also check their dowel pin.

Likewise, some '98.5-'99 owners with the 24-valve engine have reported a loose pin condition. However, according to Cummins, the dowel pin problem was corrected at '98.5 production with a staked design. So, a watchword also goes out to these '98.5-'99 owners.

Finally—and this is very important—there are four gear case bolts (three are in back of the camshaft gear the other one holds the dowel pin cover in place), that should be retightened and/or Lock-tited into place. The following text from TDR Issue 70 shows the procedure.

GEAR CASE BOLTS BEHIND CAM GEAR

When I checked the dowel pin, commonly known among members as the Killer Dowel Pin (KDP) in my '89 Turbo Diesel D250 with 182,000 miles, it had not moved. I drove the dowel pin back about 0.020-inch and peened the bore. For members who want to tighten the 10-mm gear case bolts, I have included photos of the three gear case bolts behind the cam gear that should be tightened also. The top bolt is located at about 12:30 o'clock.



The second bolt is at 2:00 o'clock. Both of these bolts are easily accessed through a hole in the camshaft gear when the crankshaft is rotated.



The third one is difficult to access and is at about 4:30 o'clock. I cut the head off a 10-mm wrench and welded it to a screwdriver to make a crow's foot type wrench to get to it. It is good to have a cheap 10-mm wrench or two to sacrifice for this project.

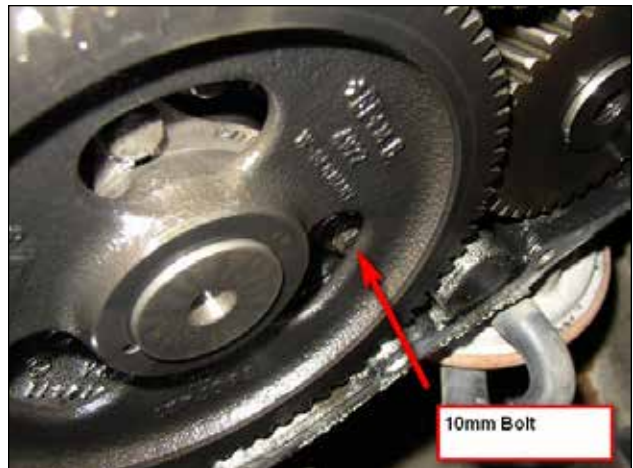

RedRamAndy, Wentzville, MO

12-Valve No-Start Condition

The bolt that clamps the positive battery cable to the driver's side battery has a stud on its head, with various leads attached. One is the hot lead to the passenger side battery. Two are fusible links, one blue and one orange. The blue one goes to the fuel shutdown relay. Either this connector or the wire often become corroded because of battery acid. If so, slip off the terminal and crimp on a new one.

The key to this diagnosis is the use of a cheap twelve-volt test light. Disconnect the fuel shutdown solenoid. There are three leads in the wiring harness: hot=start, ground, and hot=run. When the connection at the battery is poor, the test light will probably glow dimly when connected to the start pin of the wiring harness.

If your fuel shutdown solenoid is bad, usually the start circuit is the one that has burned out. If you turn the key on and pull up the fuel lever on the P7100 injection pump and the lever stays up, the start circuit is bad or the solenoid is bad.

Cummins offers a newly designed solenoid that is much larger than the original that came on our Turbo Diesels, and it comes with a much thicker mounting bracket. Otherwise it will fit right onto the pump, and its wiring harness plugs right into the Dodge harness. The Cummins part number is 3800723, but be prepared for the cost, about \$278.

Joe Donnelly
TDR Writer

MORE NO START—SOLENOID REPLACEMENT

In Issue 36 on page 36, Joe G, Eureka, CA, discusses the method of checking the fuel shut-off solenoid on the '94 thru '98 12-valve engines. The editor made note to check your local Radio Shack for generic relays at a substantial cost savings. But what do you do if the problem ends up being the fuel shut-off solenoid itself? I, like everyone else, try to save as much money as possible so I can spend money on things that I want.

I went through the diagnostic steps as Joe G stated by finding and locating the large three wire connector between the master cylinder and the engine and disconnected the solenoid from the wiring harness. The black wire with the trace is the ground and the white wire is the hot to the pull-up coil power. You will need a 10-gauge wire for your test leads. Apply the ground test wire to the black wire in the connector and 12-volts to the white wire. The solenoid should pull up. If it does not, disconnect the linkage and try it again. If the solenoid works, the problem is most likely the relay, but if it does not move, then it is the solenoid.

My local Dodge dealer quoted me \$450 for the part; my local

Cummins distributor quoted \$285. I decided to call my friend Randy at Dave's Diesel ([800] 343-73580). Dave's Diesel had one in stock for \$265 less an additional 10% TDR member discount. I decided I couldn't beat that. The new kit comes complete with new solenoid and all new brackets and heavy-duty hardware.

To remove the old solenoid, start by disconnecting the wiring harness. Then unbolt the two 8mm bolts that hold the solenoid in place and remove the clip that holds the solenoid to the linkage. Next, remove the three 8mm bolts that hold the mounting bracket to the governor housing. Finally, remove the old shutoff lever. The new kit replaces the old 8mm hardware with new 10mm hardware.

Installation is in reverse of removal. Check the length of shaft on the solenoid; it should be 2.64 inches from the top of the lever pin to the bottom of the bracket. The new solenoid linkage comes preset and tightened so you should not have to adjust the linkage, but if the linkage has been misaligned you will have to loosen the shaft locknut and rotate the adjuster to the correct length.

Just by following Joe G's easy steps I was able to save myself a lot of money and a lot of hassle. Overall the replacement took about thirty minutes and was a fairly easy job (skill level 2). Just the job for the do-it-yourselfer. Hopefully next time I will get to write about something that was not broken.

Brandon Parks
Geno's Garage

Editor's note: In a previous life I owned a '96 Turbo Diesel. I had the same no-start, need-to-replace-something problem with either the relay or the solenoid. Brandon didn't mention, but if a no-start condition occurs one of the first things you should check is the movement of the solenoid linkage. If the pull-up coil doesn't work (no matter the reason—wiring, relay, solenoid) with the key in the on position, reach below the rod and push it up! Now, drive on to your destination and troubleshoot the problem as time permits. Likewise, if you turn the key off but the solenoid doesn't release, the engine will keep running. Time to push the solenoid lever down and the engine will stop.

Final notes from the voice-of-experience: I had a heck of a time correcting my no-start problem. With both new relay and new solenoid laid out on top of the engine, the solenoid did not want to pull up. I proceeded to un-wire my hidden anti theft switch (Issue 26, page 17), but that did not help. After much frustration, the solution presented itself: the solenoid needed a little bit of pretension and it would pull-up every time. As it is installed there is pre-tension in the linkage...but there wasn't any with the solenoid laid out on top of the engine. Jeez...

Vintage '94-'04 Lock/Unlock

How do I stop the automatic transmission from unlocking when the truck is in overdrive or third gear?

Unfortunately there is not a "one size fits all" answer to this question. However, at Geno's we benefit from the millions of miles of knowledge from members of the Turbo Diesel Register magazine and from our own busted knuckle experiences.

Before we suggest some different part numbers and repair techniques we have to break this lock/unlock problem down into year models of the truck:

- '94-'98 with a 12-valve engine
- '98.5-'04 with the 24-valve engine
(VP-44 injection with the '98.5-'02; HPCR with the '03-'04)

All year model trucks may benefit from a noise isolation product from BD Power, part number BD-1300030. Interference in the throttle position sensor circuits (APPS) on Dodge Cummins engines from '94-'04 will create false voltage readings in the APPS/TPS circuit and cause the lock-up torque converter to rapidly cycle on and off as you drive. This part removes the RF interference.

If the noise isolation is not the problem, for '98.5-'04 owners the next step is to look at the accelerator pedal position sensor (APPS), also known as the throttle position sensor (TPS). The Geno's Garage replacement is an aftermarket item that is half the price of the factory unity. Our part number is TPS98502.

You can read further about the lock/unlock problem in your TDR magazine(s). Related articles:

Transmission Noise

Issue 70, page 28

Issue 69, page 30

Issue 62, page 25

Issue 54, page 38

Issue 53, page 10

APPS

Issue 68, page 29

Issue 66, page 30

Issue 60, page 92

Shift Problems

Issue 60, page 28

MORE TORQUE CONVERTER INTERMITTENT LOCK/UNLOCK

At 37 to 40–mph in third gear and at 52 to 55–mph in fourth gear the transmission in my '01 Turbo Diesel (351,000 miles) will shift in and out of torque converter lockup repeatedly. I've tried the "fixes" suggested by members, but obviously I am missing something. The alternator wires have been wrapped for years. I thought it was a defective ground at the battery since the cable has a non-factory end that was loose which I repaired. I serviced the transmission and found no problems. I replaced the accelerator pedal position sensor (APPS) assembly which didn't solve the problem. I have run out of ideas to remedy my problem.

hammersley, Camas, WA

Unwrap the alternator wires, cut the alternator ground wire and alternator charge wires out of the existing harness, and reroute them separately and away from each other. Route the alternator ground wire along the firewall to the four-way split in the harness and the alternator charge wire over the radiator support. Rerouting those two wires has the highest success rate of any fix, so you might as well start with something that works.

cerberusiam, McDonough, GA

I will try your solution. Do you have any photos of the wire rerouting modification?

hammersley, Camas, WA

My son did the modification. He actually pulled the ground wire completely out of the harness and extended it so he could route it along the firewall instead of in the engine control module/powertrain control module (ECM/PCM) harness.

He routed the charge wire from the alternator in the plastic conduit across the top of the radiator and back to the original termination point by the power distribution center (PDC).

cerberusiam, McDonough, GA

After nothing else worked, rerouting the alternator charge wire has solved the problem. Why, after 360,000 miles, did the torque converter lock/unlock problem suddenly develop? Years ago, I had the aluminum foil shielding wrapped on the harness near the alternator and no problems. What changed to make the rerouting necessary?

hammersley, Camas, WA

Deterioration of the shielding in the wire and in the alternator is the usual culprit. The frequency changed just enough to set up a different type of noise that the shielding could not filter. As age deteriorates the PCM's ability to filter specifically stray noise, it begins to make more of an impact.

Unfortunately, the electronics deteriorate to the point where they may not work and the truck may become unusable. Add on filters and tin foil will not stop the problem when the frequency changes enough to impact the PCM as it ages. The ground wire is the usual culprit, but as you have discovered, the alternator charge wire can "dirty things up" also. I'm glad it worked for you.

cerberusiam, McDonough, GA

From my testing this weekend, it appears that the torque converter lock/unlock issue on my '01 Turbo Diesel 3500 may be solved. I will know for sure in about ten days when I tow my fifth-wheel trailer to the mountains of New Mexico.

I received many suggestions on how to correct the torque converter lock/unlock issue and followed up on all of them. Check the battery cables first!



I followed the advice of TDR member "cerberusiam" and separated the alternator ground and charge wires from the rest of the wire harness. I re-routed the two wires and cleaned all the ground connections.

I also installed a Navrone noise suppression filter Model N-25 by Navone Engineering at (<http://www.davidnavone.com/cart.asp?24&cat=2> or 800-669-6139) as seen in the photos which may be helpful to other members who might want to use this electrical noise filter. I rerouted the alternator charge line and ground at the same time. After completion of the project, I have driven the truck on the highway and could not reproduce the torque converter unlock/lock issue.





Photos of final installation with air cleaner housing re-installed.



Silver Ratler, Lubbock, TX

Editor's Note: For more information on the common intermittent torque converter unlock/lock problem and suggested repairs, see Issue 73, page 32; Issue 71, page 35; Issue 70, page 30; Issue 69, page 30; Issue 62, page 25; Issue 53, pages 10 and 38. One or a combination of suggested repairs appear to have been successful.

Mystery Switch

TORQUE CONVERTER LOCKUP SWITCH FOR '96-'98 RAM

The following diagram is supplied at no cost or obligation by TST Products. Note that use of this method of lockup may be hard on vehicle drivetrain and may void vehicle drivetrain warranty. Use makes vehicle drive like a manual transmission in 4th gear such that vehicle may/will stall at low speeds/stops if lockup is not disconnected.

1. Install jumper wire in place of the trans relay in the Power Distribution Center (black box behind driver side battery) as shown in diagram below. This jumper wire will supply 12-volt positive to the transmission torque converter clutch solenoid. This jumper will be electrically hot thus it should be installed so as not to short against ground.
2. Install ground wire from the B11 orange wire with black stripe to a switch or relay such that the ground source can be turned on and off. The B11 wire is located in the middle computer connector located on the firewall behind the air cleaner.

Driver must ground the B11 wire, have gear selector in Drive, and be moving fast enough to be in 2nd gear before the torque converter clutch will engage. Transmission will shift from 2nd to 3rd, and 3rd to 4th (unless Overdrive is off) with the torque converter clutch locked. Once in 4th, the transmission will not downshift unless the ground source is interrupted, i.e. the switch is turned off.

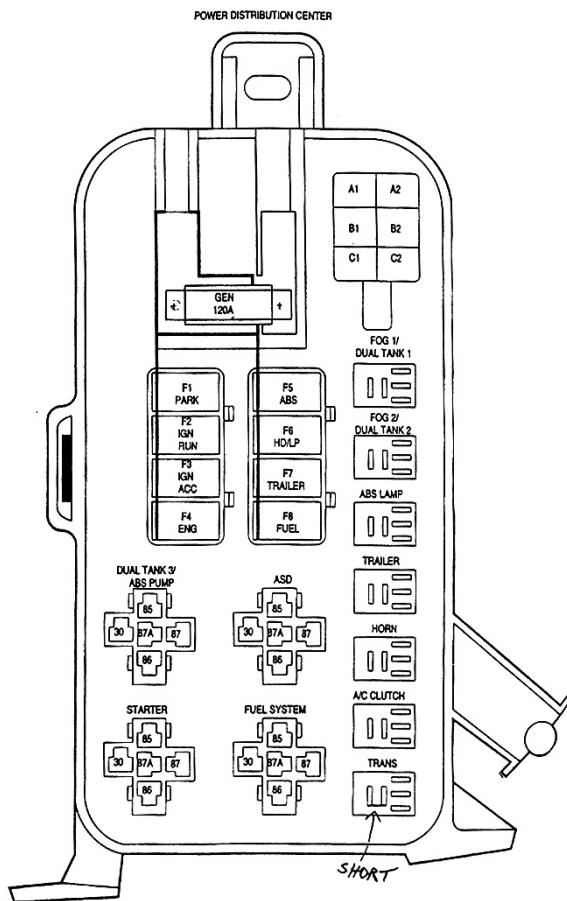

Add Jumper Wire
Do NOT Reinstall Relay
Power Distribution Center
Next to Driver Side Battery

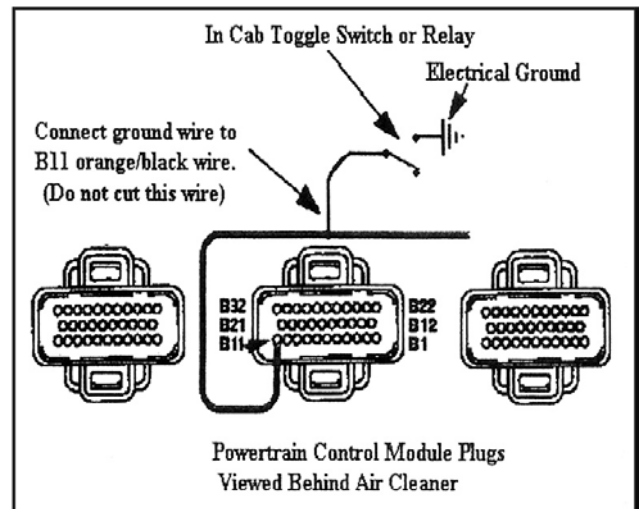

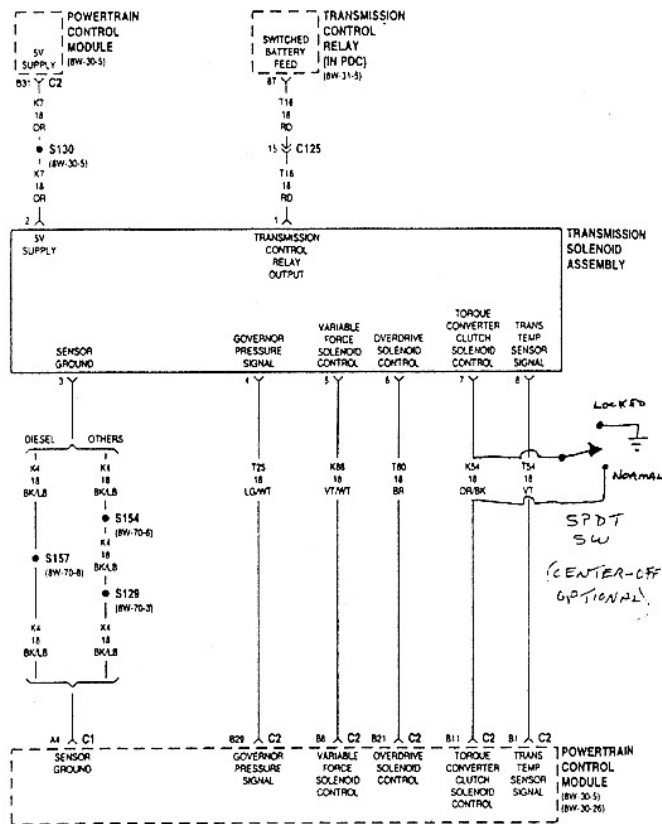

TORQUE CONVERTER LOCKUP SWITCH FOR '94-'95 RAM

The following diagram is supplied at no cost or obligation by TST Products. Note that use of this method of lockup may be hard on vehicle drivetrain and may void vehicle drivetrain warranty. Use makes vehicle drive like a manual transmission in 4th gear such that vehicle may/will stall at low speeds/stops if lockup is not disconnected.

Install ground wire from the pin 54 orange wire with black stripe to a switch or relay such that the ground source can be turned on and off. The pin 54 orange wire with black stripe is located in computer connector located on the firewall behind the air cleaner.

Driver must ground the pin 54 wire, have gear selector in Drive, and be moving fast enough to be in 2nd gear before the torque converter clutch will engage. Transmission will shift from 2nd to 3rd, and 3rd to 4th (unless Overdrive is off) with the torque converter clutch locked. Once in 4th, the transmission will not downshift unless the ground source is interrupted, i.e. the switch is turned off.

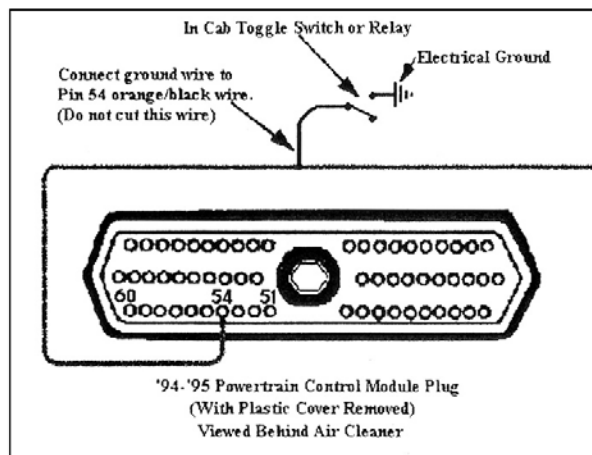

Block 53 and Class Action Settlement

THE 24-VALVE, 53 BLOCK CRACKING BLUES—FACT OR FICTION?

By Andy Redmond

History

Disquieting reports concern members who have a truck with a 53 block casting number. Although this is not the first time this problem has been addressed (see Issue 48, page 30, Block Identification and Block Replacement), I've seen little documentation as to its cause, repair procedures, or longevity of any repairs. This infamous casting number has some history (albeit limited) of the cast iron block cracking below and behind the center expansion or freeze-plug (passenger side of engine). Model years affected are late '98.5 production 24-valve engines up to 2001. Okay, now that affected model year owners have flashlight in hand and are searching for the block number, its location is found on the lower left front corner (driver's side) of the engine block behind the vacuum pump/power steering pump assembly.



You can't miss it, "block 53," on the driver's side of the engine, toward the front gear case, behind the vacuum pump.

What piqued my interest in this topic was a TDR member from Maine who called with questions about the differences between engine blocks and the cracked 53 block in his girlfriend's '99 truck with 200,000 plus miles. Seems that they had just sold the truck a few weeks prior to our conversation to an acquaintance, who had phoned the day before wanting his money back. After the transaction, the new owner was spooked. So now when you sell a used truck you have to warranty it too?

The conversation got me to thinking. After speaking further with my best friend in New Hampshire (an expert welder), Sean Tatham at North Country Welding, I ventured to the website of a cast iron guru in California named Gary Reed. Gary is both the CEO of Lock-n-Stitch and Full Torque. I further learned that Gary has almost 40 years experience in cast iron and its repair, not to mention a through knowledge of fasteners and how differing metals react to heat. It seems that Gary has a proven repair and reinforcement brackets for the 53 block. In our correspondence, Gary shared his thoughts on proper cast iron repair techniques and how

to test your 53 block for a potential failure incident. Gary also shared with me that he has worked extensively with Cummins and most of the other OEMs for both cast iron and aluminum repair techniques. Since he has extensively researched the 53 block as well as the trilogy of successor blocks, I quickly became confident that he was in-the-know.



Crack(s) occur directly above text, along the angled rail of the block, under the core/expansion plugs along the molded shelf to the angled block skirt.

Reason for Failure/Subsequent Block Cracking?

The block 53 was used by Dodge and in other ISB applications such as Freightliner, Monaco and other motorhomes. In my discussion with Gary he stated that the 53 engine block casting is too thin in a crucial area. The weak area can crack due to differing expansion rates as the metal unevenly expands as the engine comes to operating temperature. So, if you have a block 53, it is a wise practice to warm up the engine before you put it into a high load situation.

Gary has performed research at a Cummins remanufacturing facility, where he measured fifty engine blocks. His measurements allowed him to conclude that the block will not likely fail if it measures a thickness of at least .250". Cracked blocks he measured have consistently showed casting thickness in the range of .230"-.245". In order to check this dimension you will have to remove the center expansion plug and use a one-inch micrometer to measure the suspect crack area. This likely entails turbocharger and exhaust manifold removal. Again, realize that block 53s were used in many non-Dodge applications and of those block 53s produced only a few have documented cracking/failure. So, if you go to the trouble of checking the block 53 and you find it is less than .250" you've identified a block that may crack at some point during its service life. Is that 80,000, 200,000, 600,000 miles? Should you run out and sell the truck? Would you purchase a block 53 truck?

Both questions invite an emotional response. Yet, both questions can be addressed with a factual dollars-and-sense (play on words) answer. Read on.

The FIX: Meet Lock-N-Stitch

I am in the service business. Like many others my impression has been that a cracked cast iron block can't be repaired. However, Gary has one reliable way to repair cast iron. The repair technique involves heating the cast material (engine block) to 1,250°. The next step is to powder weld the cracked area. However, for our block 53 problem this method would require engine removal from the truck and complete disassembly—read: expensive and not practical.

The other obvious and expensive repair option is to source a Cummins replacement block or a good used engine. The latter will likely require honing and/or boring and oversized pistons/piston rings. Both options are acceptable solutions. Even if most everything is swapped-out, you are looking at 35-40 hours of labor.

Enter another repair technique, Lock-N-Stitch. The Lock-N-Stitch and its related fixtures allow for the repair to be done with the engine in the chassis. For access to the crack you will have to remove the turbocharger and exhaust manifold. Drain the coolant and thoroughly clean the cracked area.

The crack is then drilled with many precise holes. A fixture that is provided with the kit controls the depth of the holes and their spacing along the crack. Pins are then inserted into the holes. Manufactured by Lock-N-Stitch, the pins have a special break-off head that breaks very close to flush with the block. A grinding wheel will take the pins to flush.



Before you call this a complete repair, take some time to prevent future cracking. Lock-N-Stitch sells a support bracket (\$375 each) that adds strength to the block in this weak area. It is recommended that one support bracket be used for cracks that are up to 3", two brackets for cracks that are 3" to 6", and three brackets for cracks that are 6" to 12".



Reinforcement Bracket

The costs for one stitch kit is \$320 (1"-4" length crack) and one support bracket \$375, totaling approximately \$700. It's prudent to add at least another \$700 for labor. A skilled technician is easily able to perform this repair, albeit a tedious process.

Gary shared with me that blocks produced after 53 were thick. The post trilogy of block casting numbers after the 53 starts with an e-series block, which had no casting number, then numerically labeled blocks 54, 55, and 56.

Lock-N-Stitch also has stitch kits for the repair of Cummins cylinder heads. The 12-valve heads are infamous for cracking in the injector bore and on the integral intake and exhaust valve seats.

Andy Redmond
TDR Writer

Sources:

Gary J. Reed, CEO
LOCK-N-STITCH Inc.
1015 S. Soderquist Rd.
Turlock, CA 95380

(800) 736-8261
(209) 632-1740 fax
www.locknstitch.com

BLOCK 53 EPILOGUE

Andy Redmond's "Block 53" story was published in May 2008. His article referenced an earlier story from Issue 48 in May 2005. Subsequently, a TDR member documented his experience with the Lock-n-Stitch repair in Issue 62, November 2008.

As a conclusion to this story, in October 6, 2010, there was a class action settlement on the Block 53 fiasco. As the TDR's editor, when I read the notice my comment was, "Too complicated, too little, too late and too sad." Below is a copy of the notice.

As a reader of this Buyer's Guide you A) have already purchased a '98.5-'01 truck, B) are considering the purchase of a '98.5-'01 truck, or C) are an interested reader.

From carefully reading Andy Redmond's Issue 60 text you know that most often the problem does not occur. I wish I could give you some data on the percentage of incidents, but I don't have the answer. However, I can give you very good guesstimate on '98.5-'01 production volumes—my guess being about 310,000 trucks.

Aside from the fact that you've been educated and are aware of the situation, if you own or are considering a '98.5-'01 truck there is no good ending to this story.

YOU MAY BE INCLUDED IN A CLASS ACTION SETTLEMENT ABOUT CUMMINS ENGINES IN DODGE RAM MODEL 2500 OR 3500 TRUCKS

A settlement has been proposed in a class action lawsuit against Cummins Inc. and related entities ("Cummins"). The lawsuit is about cracks in pattern 53 engine blocks used to build Cummins ISB 5.9 liter diesel engines that were originally installed in certain 1998-2001 model year Chrysler Dodge Ram trucks.

Who Is Included? You are a Class member and included in the settlement if you purchased or leased, in the United States, its territories, or possessions a model year 1998-2001 Chrysler Dodge Ram truck, model 2500 or 3500, that was originally equipped with a Cummins ISB 5.9 liter diesel engine built using a pattern 53 engine block.

What Is The Lawsuit About? The plaintiff claims that the pattern 53 engine blocks developed a crack on the passenger side of the block, causing coolant to leak. Cummins strongly denies these claims. Plaintiff strongly believes in the claims of the lawsuit. To resolve the dispute, the parties have agreed to a proposed settlement in which Class members would receive certain benefits upon a timely qualifying request. No claims have been made about bodily injuries.

What Does The Settlement Provide? The settlement provides for reimbursement up to, but not exceeding, \$500.00 to qualifying Class members for costs incurred to repair or replace a covered pattern 53 engine block.

Will You Receive A Payment? That depends. To qualify, you must submit a Claim Form showing that the crack in the passenger side of your pattern 53 block first occurred: *after* the original engine warranty expired (in other words:

(1) after the truck was driven for more than 100,000 original miles, or (2) more than five years after the date the truck was originally purchased – whichever happened first); **and before** the truck was driven for 250,000 original miles. If your truck meets this definition, you must file a Claim Form by **October 28, 2012** to get a payment (except for qualifying Class members who first experienced a crack in a pattern 53 block after October 28, 2011, who must file a Claim Form by **January 26, 2013**). You can obtain a Claim Form by logging into www.cumminspickupblocksettlement.com using the **Notice No. on the front side of this card.**

What Are Your Other Options? If you do not want to be legally bound by the settlement, you must exclude yourself by December 12, 2011; otherwise you will not be able to sue Cummins for any claim relating to this lawsuit. If you stay in the settlement, you may object to it by December 12, 2011. The Court will hold a hearing on December 16, 2011 to consider whether to approve the settlement and any requested attorneys' fees. If you wish, you or your own lawyer may ask to appear and speak at the hearing at your own cost. **The Settlement Notice on the website explains how to exclude yourself or object. If you remain in the Class and the settlement is approved, you will be bound by it and will release all claims against Cummins about the issues in this lawsuit.**

For more information or a Claim Form: Visit www.cumminspickupblocksettlement.com using the Notice No. on the front side of this card or call 1-877-564-7093.

Steering Woes

INTRODUCTION

by Robert Patton

In a staff meeting a Geno's Garage employee shared with me the latest find from the newsstand. The headline from [Diesel-This-And-That](#) was "Cure for the Dodge Death Wobble."

Wanting to learn about the one-size-fits-all "cure," he purchased the magazine, hoping to read about the definitive answer.

If there is a single part to cure the steering problem, all Turbo Diesel owners would like to know about it. You'll find that I'm not so bold as to suggest the one-size-fits-all approach, especially considering that we have four generations of trucks to consider.

As I read the article in [Diesel-This-And-That](#), I looked closely for the author to give himself an "out." You know, using words like possibly; maybe; double-check your (fill in the blank); also consider (fill-in-the-blank). If the words were used, I missed them. Their suggested cure was the combination of a steering stabilizer and a replacement track bar, quite an expensive repair.

Again, I'm not so bold to suggest a single answer. I would rather share with you the experiences from vendors, TDR writers and TDR members. So in this article "Steering Woes" you'll find a compilation of correspondence that will get you started in the direction of correcting the problem rather than replacing parts that may or may not help. An outline of this article looks like this:

"Overview of Suspension Components,"

by TDR Writer Andy Redmond

"A Comment on First Generation Trucks,"

by TDR Writer Andy Redmond

"Is it a Simple "Rebuild of the Trackbar?"

by Luke's Link employee Michael Engle

"Comments on '94-'02 Death Wobble,"

by TDR Writer Andy Redmond

"Steering Woes on a '94-'02 Second Generation Truck,"

by TDR member Brent Boxall

"Preferred Alignment Specifications Update"

by TDR Writer Andy Redmond

Finally, I am fortunate in that I have not had any steering problems with any of the five Turbo Diesel trucks that I have owned. You can chalk this up to the fact that all of my concrete-cowboy needs are met with two-wheel drive trucks. Without the need to tinker with the steering components, I am not qualified to offer advice. However, TDR writer Andy Redmond works on these trucks day-in and day-out. So, throughout the article you'll find "Andy Redmond responds:" as he adds commentary to the other writer's material and at the end of this compilation of data, he updates his Issue 53 article with new alignment specification that includes '03-'09 Third Generation trucks. Let's get started with Andy's article "An Overview of Suspension components," followed by his "Comments on First Generation Trucks."

AN OVERVIEW OF SUSPENSION COMPONENTS

by Andy Redmond

The focus of this article on "Steering Woes" is primarily written for those '94-'02 Second Generation owners. However, I thought I would put a basic table together to show the type of suspension and known problems to cover all years of Turbo Diesel with the 4x4 drivetrain.

Owners should note that in 2003 the track bar was redesigned with the introduction of the American Axle for the Third Generation trucks. With the exception of the lesser quality ball joints and hub bearing assemblies, the front suspension on these '03 and newer, later generation trucks is substantially more robust and durable.

Year	Front Suspension Type	Known Problems
1989-1993	Leaf sprung-solid axle—Dana 60	Steering shaft rag joint. King pin wear and perhaps worn bushings in leaf spring eyelets
1994-1999	Link coil (upper and lower trailing links with coil-sprung solid front axle—Dana 60). This truck uses a track bar to align the axle between the frame rails.	Track bar wears out quickly (due to ball stud end). Small eccentric adjusters on lower trailing arms allow for insufficient positive caster adjustment. Steering gear that wears over time.
2000-2002	Link coil (upper and lower trailing links with coil sprung solid front axle—Dana 60). This truck uses a track bar to align the axle between the frame rails. There was a design improvement with the dual piston brake calipers, non captive rotors, different spindles, ball joints and larger alignment eccentrics.	Same problems as earlier Second Generation trucks, but now the ability to achieve preferred caster adjustment, due to design changes in the lower trailing arms (larger caster eccentrics). Steering gear that wears over time.
2003-2009	Link coil suspension (American Axle)	Lesser quality ball joints and hub bearings. Much improved track bar design and attachment point (track bar has two eyes, versus the poorly designed earlier style eyelet/ball stud design). A switch to a Delphi steering gear from the Saginaw part. It too suffers some reliability issues.
2010-2011	Link coil design similar to 2003-2009 models	Many subtle changes including larger sway bar links, redesigned track bar, larger steering gear/steering linkages. This steering gear shows promise of being over engineered and very robust!

I know, I know, you want to read about *the answer* to your steering woes, specifically those woes that pertain to the '94-'02 Second Generation trucks. We will get to the answer in due time. Do you dare skip ahead to my "Comments on the '94-'02 Death Wobble" or is it as simple as a "Rebuild of the Trackbar." Read on!

A COMMENT ON FIRST GENERATION TRUCKS

by Andy Redmond

As expected, the First Generation truck handled pretty well, although they didn't ride too nicely. The handling and long wearing front end parts are classic old school—a solid front axle, with leaf spring suspension, tapered roller wheel bearings and manual locking axle hubs. The steering shaft's "rag joint" is the most common steering issue. Even if the king pin (steering knuckle pivot points), and various steering end links are worn, the leaf springs center the axle (between the frame rails), resulting in a truck that usually drives fairly straight.

REBUILD OF THE TRACKBAR?

by Michael Engle/Luke's Link

Anyone who has experienced steering problems while driving a Dodge pickup truck knows all too well the symptoms: wandering or drifting and/or a shimmy, or even a violent shake when hitting a bump, known as the "death wobble." When trying to identify the specific problem, most people look to vehicle alignment, worn ball joints, steering boxes, or even tires. However, don't overlook the real problem: the ends of the track bar.

For the novice that is new to four-wheel drive, the track bar is the bar that sits under your differential and runs from the axle to the frame. This bar acts as a stabilizer to keep the truck tracking straight as it travels down the road. From '94 to '02 (Second Generation trucks) the track bar had a bushing on one end and a ball joint on the other end. Many people mistakenly replace the entire track bar when the true cause of the problem is simply the ball stud on the driver side end of the track bar. Internally Dodge put a two-coiled metal spring to hold pressure on the ball stud. Once this spring (which is not strong enough in the first place), flattens out, the bar sits on the ball stud and moves up and down. Below is a picture of the spring that wears out.

Wandering or drifting occurs while driving because when the steering wheel is moved, the track bar pulls the axle, and that "play" in the bar lets the axle keep moving. This causes the driver to pull the steering the other way and you end up constantly steering the truck.

The death wobble occurs when shock or vibration is sent from the axle to the track bar, causing the bar to shake because of the play. The shake is then sent to the frame of the truck which makes the truck shake. Generally you must slow the truck to allow it to regain its "composure."

So if you are facing either of these problems, what do you do? Some might think going with a thicker track bar will solve this problem. A thicker track bar (with the same "sloppy" ball stud) will not last any longer than the stock bar. Likewise, regardless of a lifetime warranty that is offered by some manufacturers, it is likely you will be changing track bars every 6 to 12 months.

So what is the solution? Luke's Link of Colorado offers a permanent solution to Dodge pickup tracking problems. At Luke's Link our line (technically speaking, a ball stud socket collar) was designed to rebuild and convert track bars to a fully adjustable end. With this kit, you remove the ball stud and internal parts and slide a cap or C-clamp over the end. You then install the new modified internal parts with the new modified spring being the main component. Then a large plug screws into the cap to tighten everything down. With this setup, the ball joint will never wear out. If it does, you can adjust it by unscrewing the plug and putting a spacer under the plug to shim the spring down. This only takes a few minutes to adjust. This allows the track bar assembly to last for the life of the truck.

Luke's Link has a simple check and test to determine if your track bar ball stud is bad.

- ***You need two people to complete the inspection, and at least one person should have some fairly good strength. Make sure your vehicle is parked on a solid surface with tires pointed straight forward. Do not jack the truck off the ground.***
- ***Have the stronger person sit in the driver's seat and unlock the steering wheel. Do not start the engine! The other person should be under the vehicle with a flashlight.***
- ***The person in the driver's seat should move the steering wheel back and forth fairly hard. Under the vehicle you should examine the ball stud joint to see if there is any movement up or down. Make sure you are looking at the track bar as well as the tie rod ends. The main objective is to use the weight of the truck against the axle. That is why it is important to leave the truck completely on the ground. If there is movement, your ball stud joint is likely in need of replacement. (Please note that the tie rod ends will swivel and that is normal. The track bar, however, should not move at all.) The entire replacement part kit for this repair is \$69.***

About Luke's Link

Luke's Link has sold tens of thousands of repair kits in the United States and internationally, and is recognized as a leader in specialty auto products. We've been in business for over 25 years. We've been prominently featured at many automotive web sites and in publications including Peterson's 4x4 Magazine. Owner/Operator/Inventor Johnnie Laucus has owned a front-end shop for over 30 years. Laucus and his engineer continue to expand and improve their product line. In addition to this kit working on the Dodge track bar, it will also work on the tie rod ends from '94-'06 as well as Jeep track bars and most Ford tie rod ends up to '98. Luke's Link also has developed a kit for the Dodge '03-'07 track bar bushings. The bushing kit includes two poly bushings, and new better fitting bolts for the ends. This set is \$36 and eliminates the need to replace the entire \$350 track bar.

Please don't confuse Luke's Link kits with a cheap or temporary fix. Luke's Link offers low cost solutions because it permanently solves the problems, with no need to purchase expensive or unnecessary parts. See Luke's Link on the web at www.lukeslink.com or contact us at 1-800-962-4090.

"COMMENTS ON THE '94-'02 DEATH WOBBLE"

by Andy Redmond

Luke's Link is a great company with a great product. However, I've experienced only marginal success unless the repair kit was installed on a lightly worn track bar. The kit often was not able to tighten the worn parts enough, allowing continued death wobble. Unless Luke's Link has been updated, their directions state it will not work on the slightly more heavy duty Moog DS1413 track bar.

For the Death Wobble problem on a Second Generation truck, I wrote an article in Issue 46 (November 2004) that covered the installation of a truck bar relocation bracket and a new Mopar '03-'08 track bar. Since the editor sent this article to me for my review, I went back seven years to Issue 46 to see if my opinion had changed. It has not. As I mentioned, the repair is more involved than the simple rebuild of the track bar with a Luke's Link. The parts used back then were a track bar relocation bracket from Solid Steel Industries (www.solidsteel.biz, part number DSS0019402-4, \$209) Mopar '03-'08 track bar (part number 52106795AC, at about \$250). I still use these parts. Since 2004 other companies have introduced different versions of this kit; specifically, the folks at BD Power offer a bracket and track bar kit (BD part number 1032011, \$480). My experience with the BD kit is that it is more difficult to install. The Issue 46 article (pages 154-156) has the details of the SSI bracket with the Mopar track bar.

STEERING WOES ON A SECOND GENERATION 4X4

by Brent Boxall

The problem with steering issues is that they come along slowly. Mine began at about 120,000 miles with a mechanical "clunky" feeling in the steering wheel, and with 141,000 miles on the clock, my 2001 Ram 2500 Quad Cab 4x4 had developed a tendency to move around in the lane without driver input. I never experienced the "death wobble" many speak of, but I'm sure I was a DUI suspect from time to time, especially when towing. This wandering steering issue made the truck a handful to drive so I decided to fix it. Below is a description of what I did to fix my truck, beginning at about 120,000 miles and completing the repair at about 141,000 miles. This article is not intended as a how to guide, but rather is a list of the steps I took when repairing my truck. As always, your mileage may vary.

I fixed my steering in three phases: one being from the steering column to the steering box; the next from the steering box to the wheels; and finally phase three, the tie rod ends and ball joints.

Phase One: Steering Column to Steering Box – Chasing the Mechanical “Clunk”

After searching the truck’s steering system for loose motion, I decided that the steering shaft in the bottom of the column felt slightly loose. The best way to check this is to stand next to the left front wheel and reach down below the master cylinder and grab the shaft where it comes out of the column tube. Pull the shaft up and down and feel for mechanical play or loose motion in the column bearing. Remember that a little bit of motion, like 0.002-0.003” can feel like a lot in the steering wheel.

To investigate further I removed my original steering shaft that connects the column shaft to the steering gear box. This shaft felt good in my hands when checking for rotational slop, until I realized that I had it telescoped to a different spot in its extension range than where it rode when in the truck. Upon more careful inspection I realized that at the exact point in its extension range where it was installed in the truck it had a slight amount of rotational slop, less than 1 degree, but still noticeable.

To fix one of these issues I decided to replace the bearing in the bottom of the steering column with the bushing offered by <http://rocksolidramtrucksteering.com>. The instructions supplied with the kit were very straightforward and it appears to be somewhat easier to do on my truck given it is a manual rather than the automatic trucks with the column gear selector. One note worth mentioning here is that any time you uncouple the steering system, the steering wheel is free to turn inside the cab. This must not be allowed to happen as it may bring about the destruction of the “clock spring” inside the column. The clock spring is actually a thin ribbon cable type electrical connection between the portion of the column that rotates and the part that doesn’t rotate. The catch here is that the cable or clock spring is a fixed length so if you connect the steering back up in a different orientation than it currently is, you may run out of cable when turning left or right. The best way to avoid this is to put the truck’s front wheels straight ahead prior to disassembly. Then take a cargo strap and attach it to one of the driver’s seat floor supports, thread it through the steering wheel and connect to the other seat support as shown below:



This technique makes the steering stay put while you work which avoids clock spring damage.

Andy Redmond adds to Brent’s story: The bushing offered by “rocksolidramtrucksteering.com” is a worthy modification, more for steering column wear and noise more so than handling concerns. Dodge offers a toe plate bushing for later steering columns in the Second Generation trucks, which is used to solve the problems of column wear and noise (clunking).

To replace the steering shaft I chose the Borgeson steering shaft, part number 950. The installation instructions for the Borgeson are straightforward and easy. I highly recommend test fitting the steering shaft and then using Loctite for all set screws and jam nuts. Again, follow Borgeson’s instructions, your steering system is IMPORTANT!

While I had the steering shaft out of the truck I removed the steering gearbox to check the play in it. The easiest way to get the steering box out is to remove the hydraulic lines and remove the tie rod end on the Pitman arm. The Pitman arm retaining nut came off easily but the arm seemed not to want to move. I chose not to remove my Pitman arm since it was stuck hard even after soaking with penetrating oil. I put the steering box on my bench and tried rotating the input shaft very slightly to see if I had Pitman arm movement. Using a dial indicator I determined that my steering box had very near zero loose motion in it, so the steering gear box went back in the truck.

Andy Redmond adds to Brent’s story: To adjust the steering box for wear, I use the procedure outlined in Dodge technical service bulletin (TSB) 19-10-97. Where do you find this oldie (written in 1997)? The TDR’s web site has a summary of the bulletin and a web search on “TSB 19-10-97” will uncover the entire bulletin.

Every steering gear I’ve tightened has resulted in better steering manners (less steering wheel motion before the truck starts to change directions) after tightening the preload. Please realize that this preload adjustment does not address any side play in the sector shaft that is connected to the Pitman arm.

And, although Brent didn’t remove his Pitman arm, I’ve found that before attempting to remove the arm it helps to wire brush everything, followed by a dousing of brake cleaner, chased by some penetrating oil. If needed, try some heat from a small torch. Sometimes a pneumatic impact wrench on the Pitman arm puller is necessary to pull a stubborn Pitman arm. I’ve even broken high quality Pitman arm pullers, “abusing” them in such a fashion. However, I’ve always been able to remove the Pitman arm without Pitman arm or steering gear damage, all with the steering gear on the truck!

One problem became readily apparent when I removed the power steering hydraulic hoses. My power steering fluid smelled burned and was unnaturally dark in color. I then decided to take the power steering pump off and check the condition of the pump. This observation fit with the extremely high temperature of the hose fittings near the hydraulic brake assist unit I have observed over the life of the truck. I decided to do something about high temperature of the power steering fluid. So I found an automatic transmission

fluid cooler that would fit on the driver's side of the air conditioning condenser in front of the intercooler. I designed a bracket and mounted the cooler in line in the return hose from the steering gear box back to the power steering pump reservoir.



An automatic transmission fluid cooler in its new job as a power steering fluid cooler.

This fluid cooler plumbed into the return line worked like a charm to keep the power steering fluid cool. Even on a 100° day, after driving in traffic, you can put your hand on the return line going from the cooler to the pump reservoir and it is warm/hot to the touch, a major improvement over the “roast your finger” stock system.

Problems arise! This new system worked great but the stock pump either did not have the pressure or enough flow to operate the system if I was braking while turning during slow speed maneuvers and/or when the engine's speed was near idle. This can be attributed to the additional return line back pressure created by cooler and the additional 8-10' of hose required to get out to and from the cooler. One way to tell if your power steering pump is having trouble keeping up flow-wise, is to turn the steering wheel very abruptly when the truck is moving very slowly. You will feel the power assist “catch-up” a fraction of a second later. This is a major indication that your pump isn't providing enough flow. The way to tell if your power steering pump isn't making enough pressure is during stopping and turning. If the pump pressure is low the power brake assist will be weak requiring more brake pedal pressure to stop and steering effort is increased especially noticeable during low speed maneuvers.

West Texas Offroad (www.westtexasoffroad.com) has a good description of the Saginaw pump pressure regulator and how to modify it, which I did, but still couldn't get enough performance from the stock pump. If I adjusted for pressure, I didn't have enough flow and likewise if I set up the pump for adequate flow I lost too much brake power assist and slow speed power steering assist.

Save a link to the “Tech” section of the West Texas Offroad website. The technique of removing a spacer washer to increase pressure is outlined in the next paragraph.

While searching for power steering pumps, I found Performance Steering Components at www.pscmotorsports.com. After talking with them on the phone I learned that our trucks come stock with a Saginaw 1300 Series pump and PSC offers 1300 series pumps as well as a 1400 Series high performance pump. The 1400 requires a fluid cooler, which I had just installed, so I ordered their part number SP1490. After installing the pump and some Royal Purple Max EZ Synthetic power steering fluid, I figured I was set. The pump did great on flow, but required some effort to turn the front wheels in a parking lot and also a heavy foot to stop the truck. Now the information from West Texas Offroad comes in handy on the pump pressure regulator. Take the high pressure hose off the pump and unscrew the pressure regulator per the West Texas instructions. You will notice that the PSC SP1490 comes with two pressure regulation washers on the regulator shaft. Remove one of them and reassemble. After putting fluid back in the reservoir and purging the air out of the system, it was picture-perfect. The steering was one finger, even while stopped, and all the flow you could ask for was there. I tried stopping while turning, which uses both the hydraulic power brake assist and the steering. All worked perfectly. Brake assist during a simulated panic stop was also excellent.

Andy Redmond adds to Brent's story: For 85% of TDR members considering such a modification, they would be smart to order the cooler/better Saginaw 1400 series pump from PSC as a kit.

Shimming the pressure regulator can cause exactly what Brent explains; plus, when shimming the OEM pump, I have seen the pump let go internally, leaving you with no power steering (and no power brakes—'97 to '02 hydro-boost equipped trucks), often within a few minutes of the shimming process. This is a huge safety concern. Shimming a pump is an exact science, particularly impractical without pressure gauges and a flow meter.

The Rock Solid column bushing and Borgeson steering shaft fixed the clunky mechanical slop in the steering wheel and the roasted power steering fluid problem was taken care of with the fluid cooler and high performance pump. These changes made the truck steer better than stock!

Okay, the clunky feel to the steering was gone, but the truck still wandered around in the lane, most noticeably at freeway speeds. My plan to change only so much of the system before proceeding with further changes was tested by commuting in the truck every day for a couple of months. Phase One was complete. Time to start Phase Two.

Phase Two: Steering Box to Wheels – Chasing the Wandering Ram.

One of my initial tests prior to beginning any steering work on the truck was to jack up one front tire at a time and try to rock the elevated tire in and out, top to bottom, and left to right, thinking that I could isolate loose motion to a specific ball joint or tie rod end. This test yielded no loose motion no matter how much I pushed and pulled on each tire. This made me wonder if the steering was really bad or if losing my driving skill was part of the aging process! I somehow convinced myself that the track bar must be the problem, and the truck was just too heavy for me to physically detect slop in the track bar.

Andy Redmond adds to Brent's story: Ahhh...training and experience helps when you are looking for component wear. I and other TDR writers have provided good instructions over the years on identifying loose and worn chassis parts. Our techniques are similar to Michael Engle's method (the preceding Luke's Link narrative). The basic test: an assistant sawing on the steering wheel (wheels on the ground) to test track bar and steering linkages. This, followed by a slightly raised tire, then utilizing a long pry bar (while an assistant watches) to check the ball joints and hub bearings. These methods of testing will allow you to see any worn components.

I ordered a Moog DS1413 track bar from Rock Auto and installed it. Installing the track bar is a fairly straightforward operation: just remove the bolt from the axle connection on the passenger side and remove the nut from the ball stud accessible from the driver's side fender well. Removing the driver's side wheel is a major help. To get the stud to back out of the tapered hole in the frame use some penetrating oil and a small sledge hammer to bump it out.

Andy Redmond adds to Brent's story: Ahhh...training and experience with too many sledge hammers helps when you are trying to remove tapered ball studs.

Before you resort to the hammer method, try a pickle fork, a modified Pitman arm puller or a Miller/SPX tool C3894-A to break the tapered ball stud free.

Just in case you missed it from my earlier discussion in "Comments on the '94-'02 Death Wobble," my cure-all is a combination of two parts: a track bar relocation bracket and a '03-'08 Mopar track bar. Installed on a customer's '95 Turbo Diesel 2500, his truck has over 150K miles of trouble-free operation. These parts should have been factory installed!

Although my kit came from Solid Steel Industries, I have also had occasion to install the kit from BD Power. The BD variant is more difficult to install as it also requires tedious alignment and, in some cases, later drilling holes in the cross member.

I chose Moog parts for all my front suspension replacements. It is easy to see why the Moog components are better, below is the new Moog track bar lying next to the stock bar.



This track bar replacement settled the truck down quite a bit and gave it some fairly decent road manners. I drove the truck for several months with it at this stage and decided that while it was tolerable, it still lacked the control and stability it had when new.

Since I found the steering box to be good in the Phase One inspection, I decided to look at the steering output shaft and tie rod end. I had an assistant get in the truck while I was sitting in the driveway, engine not running. I had him rock the steering wheel back and forth very slightly while I put my hands on all the joints including the steering box output shaft. It appeared that the steering shaft bearings/bushings inside the steering gearbox were good. I decided that I didn't like the steering box output shaft sticking out without any support on the "free end" and realized this could be a durability problem, so I decided to order and install a BD steering box stabilizer from Geno's Garage. The BD stabilizer is basically a steering box output shaft extension and support bearing. You remove the Pitman arm nut and then add the BD shaft extender. Next you remove the four bolts holding your front sway bar to the truck and install the BD stabilizer under the sway bar brackets, using the sway bar bolt locations and longer bolts supplied with the kit. A self-aligning flange bearing is then added to the BD stabilizer to support the newly extended output shaft. Again, follow BD's installation instructions.

The picture below shows the BD steering box stabilizer installation after two years of use.



The BD steering box stabilizer enhances the truck's steering system by giving the steering shaft support out past the point of load application which reduces stress on the steering box's output shaft bearings. It also stiffens the frame rail near the steering box mounting location, reducing side-to-side flexation.

Phase Three: Ball Joints and Tie Rod Ends

The ball joints and tie rod ends are the only tasks left! Many will advise putting the truck in four-wheel drive prior to removing the front axle half shafts. Engaging 4WD puts the spline engagement collar (central axle disconnect – CAD) inside the axle housing half on the intermediate shaft and half on the passenger side half shaft. This allows you to remove the passenger side half shaft without the collar falling down in the housing. If you leave the truck in 2WD as I did and remove the passenger side half shaft, the spline engagement collar will fall down in the engagement housing. This is not a major issue at all since you can disconnect the 4WD sensor and remove the four 1/4-20 bolts holding the spline engagement actuator/housing cover. Once removed simply put the collar on the intermediate shaft while reinstalling the passenger side half shaft. Then position the collar on the spline so that the actuator fork engages the collar and you can bolt up the actuator/housing cover. I recommend removing the spline engagement housing cover anyway to wipe the old differential lube and crud out of the sump.

Spline engagement housing on back side of front axle.



Before you put the truck up on the four jack stands, remove the hub caps and take the half shaft hub nuts off. This requires first removing the cotter pins and then a 1 11/16" socket. Penetrating oil and patience are important components for this phase of the project. In my experience the best penetrating oil you can get is mixture of 50% acetone and 50% automatic transmission fluid. One word of caution is that the penetrating oil isn't friendly to the clear coat on your aluminum wheels, so caution with runoff is necessary. However, repeated application of penetrating oil over a week's time prior to disassembly will make the job go much easier, especially with the bearing hubs.



My old Chicago Pneumatic 1/2" impact wrench having a go with a 3/4" socket adapter and 1 11/16" socket. Both nuts are standard clockwise tighten so remember patience and penetrating oil. My impact wrench took about 20 seconds per side and the nuts were off.

Safety Reminder

For working on the front suspension the truck must be up in the air so that you have clearance to work. For pressing ball joints out of the axle you will need quite a bit of ground clearance for the 'C' frame press.

I had two jack stands with a capacity of six tons each and thought that would be plenty. After using my floor jack and placing my two jack stands under the frame rails just aft of the control arm brackets I decided I had too much weight too high! The truck was fairly steady but it was possible to move it around slightly by pulling on it with my hands. It only took a second for me to decide this wasn't secure enough for me to lie under so I purchased two additional six-ton jack stands and added them under the axle.

The jack stand configuration I used is shown below.



Once the truck is safely up on the jack stands and you are confident it is there to stay, remove both front wheels. The next step is removing the brake calipers. Plan to hang them from the control arm using a wire, a Ty-wrap, or a hook so that the brake hose is not stressed. Never drop the caliper or allow the hose to hold the weight of the caliper. The brake rotor should now slide off to reveal the bearing hub. (Unless you have a '94-'99, which is a different design.)

With the brake rotors off both sides, this is a great time to break this project down into two projects: tie rod ends and ball joints. (Well...maybe four projects. You may want to change the front differential oil while the steering components are out of the way.) I recommend removing the steering damper at the axle, the tie rod end out of the end of the Pitman arm, and the tie rods from each steering knuckle.



Remove steering damper.



This allows the entire steering tie rod system to come off in one assembly so the new components can be assembled to match. Care must be taken when handling the entire steering system as an assembly since it is heavy and the tie rods can allow the components to rotate and pinch your finger(s) between the various rods. (Ask me how I know.)

With the tie rods and steering damper off, now is a good time to get a drain pan under the front differential and remove the differential cover. To remove the differential cover, remove all the bolts holding it on and use a putty knife to separate it from the differential housing. If your oil needs to be changed, draining it now will limit the amount of oil that drips on the floor while the half shafts are removed. Remove all the residual sealant from the sealing surface on the differential housing and differential cover, taking care not to allow any sealant flakes to get into the differential housing. Don't forget to take a clean rag and wipe the wear particles out of the bottom of the differential housing. Your gears and bearings will thank you.

Now for the bearing hubs! With the rotors off, half shaft nuts removed and the tie rod end removed from the steering knuckle, the fun of getting the bearing hubs off begins. Remove the ABS sensor if equipped and tie it back out of the way so the cable and/or sensor can't get damaged. Many pullers exist that connect onto the lug studs and push on the end of the half shaft in an attempt to get the bearing hub off. I don't like these since the reaction force is pushing the half shaft back into the axle. The factory service manual instructs one to back off of the four hub/bearing housing bolts ¼ inch each. Then tap the bolts with a hammer to loosen the hub/bearing from the steering knuckle. Welcome to Fantasy Island! With 141,000 miles on my truck, the bearing hubs didn't respond to "tapping with a hammer."

The solution turned out to be a Lisle (LIS39300) Front Hub and Knuckle Separator from ToolTopia.com and my pneumatic impact hammer.



Andy Redmond adds to Brent's story: I've used all the methods for stuck hub bearings and by far both the easiest and best method is the deep socket extension trick or Snap-On Tool DHP1. Use of the Snap-On tool wedged against a loosened bolt and against the axle tube while an assistant turns the steering wheel will pop them loose every time. Alternate the tool between the bolts to walk it off little bits at the time. In fact, I can even do it by myself, although it's a lot of running back and forth. Most DIY's don't have an air chisel or compressor with adequate power for Brent's pneumatic impact hammer task, plus you don't ruin what bit of hearing you have left, huh?

If you want, you can review my write-up on the Snap-On Tool DHP1 by looking at TDR Issue 69, page 120.

Use the LIS39300 with your pneumatic hammer on the backed off bolts, maintaining a solid backup behind the impact hammer so the blows work the LIS39300 instead of reacting back into a loosely held hammer.

The face of the LIS 39300 is hollow so it won't beat up the hub/knuckle bolts. With patience and penetrating oil (and sometimes a little heat) the hubs will come out. With the passenger side knuckle turned to the right you run the impact hammer on the front two bolts, and with the passenger knuckle turned to the left, the rear two get the impact hammer. Opposite for the driver's side. One thing I noticed is that the housing must be "walked" off evenly. As you run the LIS39300 equipped impact hammer on the front two bolts the hub will come out on the front. Place a putty knife and then screw- driver in this gap so when you begin to hammer on the rear bolts it will help to force the hub out. Once the bearing hubs are off, gently ease the half shaft out of each side and lay them on newspaper. The trick here is to keep the spline and sealing surface of the shafts clean and scratch free.

With the bearing hubs and half shafts out, remove the nuts on the ball joints and the large retaining ring off the bottom ball joint as shown below.



Also note extensive use of penetrating oil, it really does help.

The next task is to get the steering knuckles off the ball joint studs. This job can be done easily with your pneumatic impact hammer and the Lisle stepped pickle fork kit (LIS41400) at www.tooltopia.com. Run the largest fork between the knuckle and the axle yoke at the lower ball joint. Then take a sledge hammer and tap the knuckle near the upper ball joint. With patience and penetrating oil (maybe a little heat), the knuckle will pop free.

With the knuckle off both sides it is time to remove ball joints. For pressing the ball joints I ordered the QT1065 press set from www.quad4x4.com. This kit had very clear instructions and worked great. The best feature of this kit is that all the different press stubs and receivers are numbered and the instructions list which ones to use for removing and installing both the upper and lower ball joints. Again, patience and penetrating oil will get the ball joints out. This is a great time to clean up the steering knuckles, especially the bearing receiver bore.

Reassembly

Now to put it all back together again. All components should be cleaned and mating surfaces checked for damage. Leave the grease fittings out of the ball joints until after installation, as the grease fittings are easily damaged.

The first task at hand is to apply anti-seize to the new ball joints and install them per the Moog instructions. I used Loctite C5-A copper based anti-seize lubricant, part number 51007. Again, I used the Quad 4x4 instructions for operating the QT1065 press.

Notice that Moog specifies that the ball joints are to be oriented with the grease relief INBOARD when installing. Take extreme care to get the ball joints started straight so that they don't 'dig in' and scar their receiver bores in the axle yoke. Verify that the lower ball joints are pressed in far enough to allow proper installation of the new snap ring which is included with each new Moog lower ball joint. The boot must be installed on the lower ball joint after installation. This is best done with a 1-1/2" PVC pipe coupling and a small sledge hammer. Make sure you have the correct orientation for the boot, grease relief notch to the inside, and place the boot onto the ball joint and push using the PVC pipe coupling to hold it in place. Take the side of the head of a small sledge hammer and bump the bottom of the PVC pipe coupling and the boot should install correctly. Verify that the boot is installed evenly all around.

Install both steering knuckles with anti-seize in the tapered ball joint stud bores; install the ABS cable brackets under the upper ball joint nuts; and torque all nuts per the instructions supplied with the Moog ball joints, paying particular attention to the torque sequence, intermediate torques, and final torques. Make sure to install the cotter pin on each ball joint stud/nut after achieving final torque.

Andy Redmond adds to Brent's story: Another precaution about leaks: be careful not to put the axle in a bind with an extreme ball joint angle ('94-'99 trucks). A member that read Issue 53 e-mailed recently complaining of axle shaft seal leaks after installing upper adjustable ball joint sleeves. The fix was to use the lower trailing arm eccentrics and the adjustable upper ball joint sleeves in tandem to achieve about four degrees of positive caster versus his chosen value of six degrees. This allowed the spindle and axle to return to a more neutral and centered position, easing the stress on the axle seals. This was the luckiest guy ever. When he returned the adjustments to my recommendation, the seals stopped leaking. This is certainly not typical. Be forewarned: it's a big job to change these seals. On the driver's side the differential carrier has to be removed from the axle housing (labor guide—7 hours).

The next step involves installing the half shafts into the axle tubes. Visually check on the passenger side by looking down the axle tube to see that the splined collar is in position, which it should be if you shifted into 4WD prior to beginning this project. If it isn't, you will see that it has dropped down

and is too low to engage the passenger side half shaft. If the ring has fallen down, the procedure that follows will get you going again.

If you left the truck in 2WD, as I did, open the spline engagement housing or central axle disconnect (CAD) housing and place the spline collar onto the intermediate shaft's spline. You should clean out the housing sump at this time. Leave the CAD open until after the passenger side half shaft and bearing hub are installed.

There are two tasks to pay close attention to when installing the axle's half shafts: one is to get the spline and the oil seal sealing surface super clean and then apply a light coating of grease; the second is to keep it clean during the installation process by rolling up a piece of heavy paper and putting it inside the axle tube. Ideally the paper should be stiff enough to support its shape and wide enough to stretch from the oil seal to outside the tube where it can be grabbed after shaft installation. The object here is to *never* allow the spline or shaft to touch the inside of the tube since rust or dirt particles could be picked up and deposited on the oil seal lip resulting in an axle oil leak, hence the need for the paper. Once the half shaft is installed the paper is removed by pulling and tearing, you'll want to verify that all the paper came out. I used the front and back cover off a Bass Pro Shops catalog, which worked perfectly.

The next step involves installing the bearing hubs in the steering knuckles. One of my observations when looking the truck over at the beginning of this project, was that while my bearings had no noticeable slop or loose motion in them, they made a clicking sound when rotated by hand. Given the suspicious clicking noise, and the fact that you can't disassemble the bearing hubs to inspect and repack the bearings, I decided to replace my bearing hubs. I chose the Timken HA590203 bearing hubs from Rock Auto since my truck has four-wheel ABS.

To install the bearing hubs first make sure the half shaft splines are clean and coated with anti-seize. Next, coat the bearing receiver bore in the steering knuckle with anti-seize and install the bearing hubs, ABS sensor hole up. Don't forget the brake rotor shield goes on with the bearing hub. Make sure to get all four bolts on each bearing hub to proper torque incrementally: top front, bottom rear, lower front, top rear.

With the bearing hubs installed, the hub shaft nuts can be installed, although final torque can't be achieved until the truck is back on the ground. Since the half shafts are installed, the front differential cover can be reinstalled and the differential filled with the proper lubricant.

Dodge doesn't use gaskets on the differential housing, but instead uses a gray colored sealant which must be completely removed with a razor scraper prior to reassembly. I chose to put the differential cover back on with a Felpro axle housing gasket, AutoZone part number RDS6095-1 for the Dana 60 front axle, since I'm not a big fan of the gasket-less assembly idea.

Now the tie rod end assembly can be replaced. I laid my entire assembly out on a table as it came off the truck and then laid the new parts next to the old ones. Pay particular attention to the amount of engagement the old rod ends have in the alignment adjusting sleeves. The object here is to build up the new assembly to exactly match the old one both with tie rod orientation and lengthwise adjustment. The truck will still require a front end alignment, but it is better to get as close as you can to save on tire wear enroute to the alignment. This is a great time to take a thread file and thoroughly go over each new threaded rod end prior to assembly. I found that the cardboard thread protector tube had come off one of mine inside the shipping box and had collected some dings in a couple of the threads. These nicks make for hard turning adjustments during front end alignment.

Once the new tie rod assembly has been built up it is time to install it onto the truck. Prepare the tie rod stud receiver hole in the Pitman arm and in both steering knuckles by cleaning them, inspecting for cracks or other damage and coating it with anti-seize. Carefully lift the assembly to the truck and install into the steering knuckles and Pitman arm. Verify that everything looks right and then install the steering damper. Install all tie rod stud nuts to proper torque and install the cotter pins.

This concludes the assembly of the steering system. Review every aspect of your work to make sure that all components are installed correctly and that all proper torques were achieved during installation.

Once satisfied that everything is in order reinstall the front brake rotors with anti-seize on their bores and install the brake calipers. Make sure that the rotors are clean and lubricant free. Install both front wheels and place the truck back on the ground. Now comes the torquing of the bearing hub / half shaft nuts using the 1-11/16" socket and following the Timken installation instructions for proper torque. After final torque is achieved, install the cotter pins.

Parts used on this front end rebuild are:

Description	Manufacturer	Part number	Quantity
Steering damper	Monroe	SC2964	1
Tie rod end	Moog	ES3526	1
Tie rod end	Moog	DS1462	1
Tie rod end	Moog	ES3527	1
Tie rod end	Moog	DS1460	1
Ball joint	Moog	K7394	2
Ball joint	Moog	K7397	2
Track bar	Moog	DS1413	1
Bearing hub w/ABS	Timken	HA590203	2

Andy Redmond adds to Brent's story: Many members may also have severely worn upper and lower arm trailing bushings, which can also allow unwanted fore and aft axle movement. Replacement bushings are available from Dodge and the aftermarket to re-bush the trailing arms. This is most easily accomplished by removing the trailing arms, then removing/installing the bushings with a shop press. Urethane replacement bushings (Energy Suspension) are available, but these require periodic grease lubrication to prevent squeaks and may add harshness to the ride. (Urethane does not flex like a rubber bushing.) My favorites are the beefy lower links from Solid Steel Industries. The SSI Lower Adjusting Links are recommended for heavy off-road use and ease of caster adjustment. Modifications are necessary to use these on the '94-'99 trucks, as the installer must provide inner bushings to bush the link's inside diameter down to the OEM fastener shanks.

Conclusion

Well, gang, does that conclude the correspondence on steering woes and the solution to the Second Generation truck's death wobble? Since most all of the components were replaced, I would hope the answer is "yes."

Brent Boxall
TDR Member

Editor's note: My thanks to Brent for the complete write-up covering Second Generation steering problems and to Andy for his additional Shop Floor insight. To close out this article, please make note of Andy's updated alignment specifications for '94 to current 4x4 Turbo Diesel trucks that is shown below.

PREFERRED ALIGNMENT SPECIFICATIONS UPDATE

by Andy Redmond

Year	Toe	Camber	Caster	Comment
1994-2002	0 deg. or (+0.10 total toe in)	0 deg. (±.50 deg.)	3.5-4.0 deg. positive	'94-'99 trucks will require an offset fixed or adjustable upper ball joint sleeve to obtain these specifications (caster). Trucks needing camber adjustment will also require sleeves, and the '00-'02s upper adjustable ball joints.
2003 to present	0 deg. or (+0.10 total toe in)	0 deg. (±.20 deg.)	4.0-4.5 deg. positive	0-2" Leveling kits seem to like about 5 to 5.25 deg. pos. caster.
2003 to Present Cab Chassis	0 deg. or (+0.020 total toe in)	0 deg. (±.20 deg.)	3.75-4.0 deg. positive	These differences are likely due to these vehicles being used at GVWR capacities.

FUEL TRANSFER PUMPS REVISITED

The following article is from Issue 56 of the Turbo Diesel Register. It was written in May of '07 by TDR Editor Robert Patton.

As the deadline for Issue 56 was fast approaching, I called TDR writer Jim Anderson. Jim is the point guy for miscellaneous e-mail and phone inquiries that come into the TDR. I asked, "Hey Jim, what's on the minds of those that you are corresponding with?" His response, "It seems that problems with the Third Generation trucks vary. There is not a common complaint that needs to be addressed." This is good news for the Third Generation crowd.

Jim continued, "However, with the used truck purchase of '98.5-'02 vehicles the education about fuel transfer pumps is an endless task." I responded, "Ouch, I know what you mean. Perhaps I should emulate the country music singer David Allen Coe's efforts to write the perfect country music song by writing the perfect transfer pump article." Jim responded, "Keep it simple, try the catch phrase from the Millionaire show 'Is that your final answer?'"

Thus, I present the final-answer, perfect transfer pump article. While the article focuses on the '98.5-'02 owners, this collection of TDR oldies also has tips for '94-'98 12-valve owners and '03-'07 HPCR owners. The information was pulled from our Issue 32, 48, and 50 magazines. Updates have been added to reflect the latest part number information.

Then, to add a final crescendo to the article, I'll share with you a story that will be of interest to 300,000+ owners of '03 and '04.5 HPCR owners.

Below is an outline of the topics that will be covered.

- '98.5-'02 trucks, correct fuel pressure
- '94-'98 12-valve, fuel transfer pump replacement
- '98.5-'02 24-valve, fuel transfer pump replacement
- Fuel pressure gauges and opinions
- '98.5-'02 24-valve, fuel transfer pump relocation kit
- '98.5-'02 24-valve, what to do
- '03-'04.5 HPCR, what to do
- '05 to current HPCR, what to do

Here we go...

CORRECT FUEL PRESSURE— '98.5-'02 TRUCKS

In May of 2001 there was a great deal of concern about fuel transfer pump delivery pressures. The problem first surfaced as a result of a production batch of inadequate transfer pumps and the resulting product recall. Hand-in-hand with the recall was the increasing number of warranty claims. (When the article was written the early '98.5 engines were 2.5 years old.) The problems were aggravated by those that hot-rod their trucks as well as purchase fuel system accessories that add restriction to the system. The bottom line is that the 24-valve's Bosch VP44 electronic fuel delivery pump needs to see at least 5-6psi of pressure from the fuel

transfer pump. Less than 5-6psi (more is better) and there is a danger of "overheating" the VP44 pump for it uses fuel to cool and lubricate its internal parts.



In the photo, note that the Editor's truck (a '99 model) is outfitted with two gauges—one is a mechanical, liquid-filled gauge and the other is a Westach electrical gauge with a pressure sending-unit mounted to the filter head assembly.

In order to install a gauge, the '98 and '99 24-valve engines have a filter head with easily accessible 1/8 NPT fittings. On the 2000 and up trucks the service design team at Cummins was mindful of the need to test the fuel transfer pump's delivery pressure. Thus, your truck is equipped with a "banjo adapter with a Schrader valve assembly." Say what? For clarification let's look at a photo and a description.



On the inside, the part with the rifled opening attaches the fuel line to the fuel pump. On the outside, the Schrader valve (think A/C valve or, better yet, a tire valve) has a press-for-pressure needle. Here is the catch, you can take the pressure needle out of the Schrader valve.

What Pressure Should I See?

The readings that I am seeing on the gauge:

- 13-14 psi at idle
- 12 psi @ 2000 rpm – no load
- 11 psi @ 3000 rpm – no load
- 10 psi @ 3500 rpm – no load
- 10 psi @ various rpm – 10 psi boost
- 8 psi @ various rpm – 20 psi boost
- 3 psi @ various rpm – 30 psi boost *

*From the readings at idle and at various rpm with a load (and a resulting boost reading that is at stock truck/20 psi or below levels), the gauge checks out okay. As I push the performance envelope with my hot-rodged engine (i.e. the 30 psi boost reading), the fuel pump is marginal.

Does the fuel pump meet the stock specifications? Yes. Is it ideal for my truck's hot-rodged performance? Good question.

In discussions with other hot-rod owners I find that the old adage, "I am my own warranty station" once again proves correct. As you increase the output power of the engine from its design, the hot-rodder has to look at upgrading other components. Discussions with other owners have uncovered various solutions to the low pressure at high performance blues: drilled out banjo bolts for better fuel flow, bigger fuel lines, different fuel pumps, different pump locations. The saga will continue.

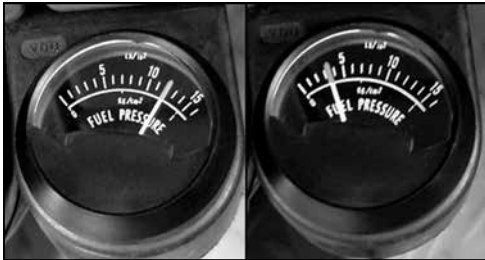

FROM ISSUE 40: '94 TO '98 12-VALVE FUEL TRANSFER PUMP REPLACEMENT

by Brandon Parks

I did not think fuel transfer pumps on 12-valve engines were a problem. I recall reading the "Backfire" column in Issue 39, where the editor states, "The old 12-valve engines used a mechanical fuel pump (the type driven off the engine's camshaft) which is essentially problem free." Nevertheless, as I started to read more about the transfer pump for 12-valve engines on the TDR website, it became obvious that there are many instances of pump failure. Is this something that we 12-valve owners should be watching out for?

Warning Signs

The first sign suggesting that my pump might be failing was very hard startups in the morning. Then I noticed that the idle rpm was slowly getting lower and when driving the truck it had lost its pep. Finally, the truck just wouldn't start. After running a fuel pressure test to determine the problem, I concluded that it was the fuel lift pump. You can purchase a new lift pump from a Cummins distributor for around \$170.00 (part number 3936316; gaskets, 3939258 at \$1.68).

Replacement

Following the procedure in the Service Manual, the first step is to disconnect the battery terminals. The instructions read to remove the starter motor (Remove the starter...there has to be a better way.), place a drain pan below the pump, remove the fuel line fittings at the top of the fuel pump, and fuel heater housing. Next, remove the fuel hose clamps and rubber fuel hose. (You can leave them connected and remove after you have removed the fuel pump and fuel heater.) Remove the two mounting bolts. Remove the fuel pump and fuel heater as one unit. Be careful not to allow the plunger to catch on the edge of the hole in the cylinder block and drop into the engine. As intimidating as this sounds, you would have to try to do this, as the plunger has to be pulled from its bore. Simple enough?



Carter lift pump with plunger removed.

Helpful Hints

Instead of removing the starter motor, I decided to get really acquainted with my engine and come in from the top of the engine compartment. This appeared easier than trying to work around the front differential to remove the heavy, bulky and greasy starter. The only problem is that when you try to reinstall your fuel pump and fuel heater unit you cannot push the pump back into place because your arms are not long enough to get any leverage to push the plunger against the camshaft. This is the voice of experience (and about an hour of labor and an evening in the easy-chair thinking about the problem) speaking to my fellow TDR members. Learn from my situation that there is a simple solution, thus making the top-removal a practical service technique.



Carter lift pump with regular mounting bolt and longer temporary bolt.

Here is the secret: When you remove the fuel lift pump, take one of the two mounting bolts and find a replacement that is the same metric thread size but about $\frac{3}{4}$ " longer. You probably have one in your parts box or you can borrow one from elsewhere on the engine. When reinstalling your lift pump use the longer bolt as your starter bolt. Once you get the lift pump and fuel heater partially tightened down, install one of the original bolts in the other hole. Once it is partially tightened, remove the longer bolt and replace it with the other original bolt. Tighten the two bolts to 18 ft-lbs torque. (Tighten the two bolts alternately to prevent damage to the fuel pump housing.) I thought this was the easier and less time consuming way than removing the starter and trying to be a contortionist by working my way around the front differential.

Next step, bleed air from the fuel system. Begin by loosening either (doesn't matter which) of the two 10mm bolts on top of the fuel filter housing. This will allow the air to escape as you prime the system. When priming the fuel system, begin by pushing the primer button a few hundred times and when you finally feel like your thumb is about to fall off, do it a few hundred more times. Seriously, don't use your finger to push the primer button. My favorite tool for this job is a jack handle (from one of those cheap automotive two-ton jacks) that has a slot in the center of the open-ended pipe.

Another method that's been used at Geno's Garage is using an old broom handle to push the primer button. I decided to make my broom handle a little easier to use by taking a $\frac{3}{4}$ " PVC coupling and sliding it on the end of the broom handle and drilling a hole about a $\frac{1}{8}$ " below the top ridge and installing a bolt in it. This is to help prevent the rubber boot from tearing. This will always come in handy when you have to prime the fuel system. When you hear the fuel hit the pump, try starting your truck.



Broom handle, 3/4" coupling with hole drilled and bolt.



Broom handle, 3/4" coupling with hole drilled and bolt.



Broom handle assembled.

Overall, it was a fairly easy installation. Skill level: give it a five on the 1 to 10 scale—make that a three, you know the shortcuts. Using the longer bolt and the broom handle made it much easier.

**Brandon Parks
Geno's Garage**

FROM ISSUE 34: '98.5 TO '02, 24-VALVE FUEL TRANSFER PUMP REPLACEMENT

by Robert Patton

In two previous Issues of the TDR we've followed the editor's difficulties with his 24-valve engine (self-inflicted VP-44 fuel injection pump failure—Issue 30, page 36; marginal fuel transfer pump performance—Issue 32, page 39). In this issue we continue the saga with the replacement of the fuel transfer pump.

Hindsight is 20/20. With the marginal performance of the fuel transfer pump I should not have installed the performance module and then drag raced the truck. The Bosch VP44 fuel injection pump needs fuel for lubrication and for cooling. With its acknowledged marginal performance, would the VP44 fuel injection pump fail? "As you increase the power output of the engine from its intended design, the hot-rodder has to look at upgrading other components." This hot-rodder should have looked closely at this fuel transfer pump's performance, as I knew it wasn't up to par. The VP-44 bit the dust, leaving me stranded at the drag strip.

Fuel Transfer Pump Failure

After the installation of a Westach fuel pressure gauge, the fuel transfer pump on my truck would only give a reading of 3 psi. Having earned the degree of "shadetree mechanic," I first looked at my workmanship with the gauge for the cause of the problem. As a test bed for products sold at Geno's Garage, the truck is equipped with two fuel pressure gauges—one reading fuel pressure prior to the fuel filter, the other reading fuel pressure after the fuel filter. Yes, they both showed 3 psi. I swapped the sensor leads and even tried a replacement sensor to see if the problem was with my workmanship. The reading was still 3 psi.

Convinced that the transfer pump was the problem, I ordered a fuel transfer pump from Cummins. Likely this could have been covered under the engine's warranty, but I did not have time to spare. The latest Cummins part number is 3990082 (the part numbers have been changing with much frequency). The cost, \$160. The 3990082 kit includes a wiring pigtail to allow the pump to be used in all 24-valve applications. I also ordered four fuel line, banjo bolt gaskets, part number 3963983 at approximately \$1.00 each.

Before examining the illustrations of the transfer pump, let's refer to the Dodge Service Manual for their pump removal instructions. When I read Step (3): remove starter motor, I knew two things. One – I don't have a service bay with a hydraulic lift allowing access to the starter motor and transfer pump from underneath. Two – I would not be doing the job as outlined in the Service Manual.

Sounds like an opportunity to rewrite the manual. Can this job be accomplished from above? You bet, and it is not as difficult as one might imagine. Follow the pictorial for tips on how to do it.

Step (1): This step is not pictured, but it involves the common sense recommendation of disconnecting and pushing the oil dipstick tube and other related cables and wires out of the way of my access-from-above service location.

Step (2): Remove the fuel supply line from the transfer pump. From the bench-picture you can see the two, blue quick-connects that you push in to release the fuel supply line.



Pinch the blue disconnect and the fuel line will come loose.



The fuel line to the transfer pump and the fuel line that goes to the fuel tank are pictured here.

Step (3): Disconnect the transfer pump's wiring harness.

Step (4): Disconnect the supply-to-filter assembly fuel line from the transfer pump. A 17 mm "stubby" wrench works wonders for the removal of the banjo bolt holding the fuel line to the transfer pump.

Step (5): Loosen the three 15mm nuts that hold the transfer pump to the bracket. Remove the 10mm bolt that positions the fuel line to the bracket. Remove the 15mm nuts that you previously loosened and remove the transfer pump.

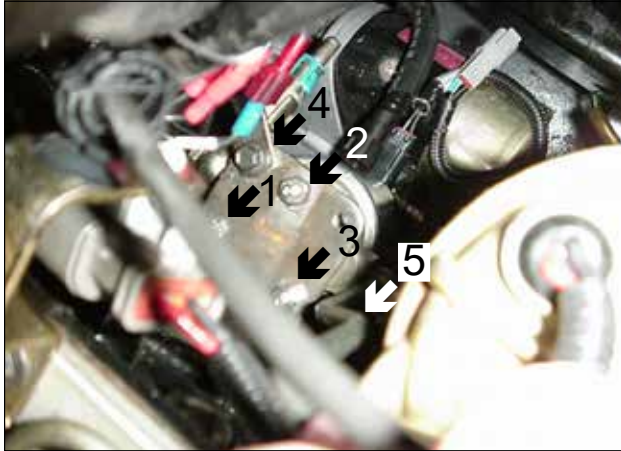

The three 15mm nuts that hold the fuel transfer pump in place (1-3) and 10 mm bolt holding the fuel line (4). Arrow 5 points to a fuel line that you have to remove with a 17 mm stubby wrench.

Step (6): Remove the supply-from-tank fuel line from the old transfer pump and reinstall loosely on to the new transfer pump.

Step (7): Reinstall the new transfer pump. Reconnect wiring harness and the fuel lines—the torque specification for the banjo bolts is 18 ft-lbs. Reconnect the supply line from the tank by pushing the line into the quick connect fittings. Listen for the fittings to click.

Step (8): Purge air from the fuel system (easier said than done). This can be a long and arduous experience. Turn the key to start the engine (that is, briefly turn the engine over). Let the key come back to run. Leave the key in the run position and listen for the fuel pump to operate. It should run for 25 seconds. Repeat this procedure at least four times before trying to start the engine. Continue until the air is purged from the system. It is normal for the engine to sputter and cough.

Step (9): Engine cranks? You're finished.

Robert Patton
TDR Editor

FUEL PRESSURE GAUGES AND OPINIONS

by Robert Patton

Let's continue and discuss fuel pressure, fuel pressure gauges and opinions. To start let's look to Webster's dictionary for a definition.

Webster's: opinion *n.* 1. A brief, conclusion or judgment not substantiated by proof. 2. An evaluation based on special knowledge.

The TDR offices are only 20 steps away from the accessory business of Geno's Garage. The Geno's phone rings and the voice on the intercom asks for assistance, "Can someone help the customer on line one with a fuel pressure gauge question?" Should the Geno's staff offer an opinion based on Webster's first definition or Webster's second definition?

Future success in business dictates that definition 2 be used. As I've overheard the dialogue so many times, the exchange goes something like this:

GG: What year model truck do you own?

Customer: It's a truck (pick your year '98.5 to '02) with a 24-valve engine. I've heard opinions that I need a fuel pressure gauge. What do you think?

GG: Yours is a 24-valve engine—yes, you need to monitor the fuel pressure. We've got gauges and accessories in stock that will make installing the gauge an easy project.

Customer: Okay, what do you suggest and how do I install a gauge?

GG: Do you want the long story or the short story?

Customer: I've got time.

GG: Here goes... The 24-valve engine's VP-44 fuel injection pump relies on fuel from the transfer pump to keep the VP-44's internal parts lubricated and cool. A bad fuel transfer pump (and the transfer pump is known to be problematic) means a loss of fuel pressure to the VP-44 and often leads to the demise of the very expensive VP-44 injection pump. A fuel pressure gauge for a 24-valve engine is mandatory.

As for the installation, you will be dealing with fuel, albeit less volatile diesel fuel. Nonetheless, you want to minimize the possibility of fuel leakage. On the '98.5 and '99 trucks the filter is in a housing and the housing drops down from a horizontal filter bracket. On top of the bracket are two ports that are tapped and plugged with a 1/8 NPT plug. The innermost plug is the clean side of the filter. Remove the innermost plug and install an electric Westach fuel pressure sending unit. Because the Westach fuel pressure gauge does not always match other gauges that owners have installed, the gauge can be mounted at the bottom of the kick-panel in a rubber donut mounting kit. This keeps the gauge hidden and unnoticed. Because the Westach gauge is electric, the chance of fuel leakage is minimized.

There are no fuel isolators to malfunction, and therefore no fluid can leak into the cab. The Westach gauge is also the least expensive and least prone to give the customer a problem. Low cost and dependability—an unbeatable combination.

For the '00 to '02 trucks the fuel filter assembly was changed to make fuel filter changes easier to perform. To change the fuel filter one simply removes a plastic cap and the filter comes out of its housing. For those wanting to install a fuel pressure gauge this presents a problem, as tapping into the fuel system is no longer as easy as removing a 1/8 NPT plug. The first solution that we offered called for replacing one of the fuel system banjo bolts with a bolt that was drilled and tapped to accept a 1/8 NPT pressure sending unit. Unfortunately, none of the banjo fittings are located in a vertical position. Common sense dictated that mounting a 6-ounce sending unit that is on an angle into a fragile banjo bolt on an engine that vibrates is not a good idea.

At first we suggested that customers purchase a 1/8" NPT hydraulic "whip hose" for a grease gun and use the hose to plumb from a tapped banjo bolt to a mounting point for their Westach pressure sending unit.

As the technique evolved, TDR member John Holmes developed a hose that would screw onto the Schraeder-valve, test port and also screw onto the 1/8 NPT male Westach pressure sending unit. After several generations of hoses, the Geno's group now offers a universal hose kit to access the fuel system's pressure.

Customer: Wow, that's a story! It is now easy to understand the answer for 24-valve customers.

GG: For '98.5 and '99 owners all that is needed is the Westach electronic fuel pressure gauge and an acceptable gauge mount. The '00 to '02 owners should purchase a universal fuel line, a Westach gauge and an acceptable gauge mount.

Customer: Do you have any suggestions about transfer pump replacement for the '98.5 to '02 owners?

GG: Okay, this is another of our favorite topics. Many TDR members have added aftermarket fuel pumps to work in tandem with or in lieu of the existing factory pump. The drawback to any aftermarket accessory is that the owner is now responsible for installation of the product, special parts and tools to support the installation, and parts necessary should the new-and-improved accessory fail.

Admittedly, the original fuel transfer pump has been problematic. However, before I would recommend going the aftermarket route, I would suggest the keep-it-simple-stupid solution. Purchase a spare Cummins transfer pump. Yes, the part number has been superseded numerous times (the final kit number: 3990082). The current price at a Cummins distributor is \$160. Next, read (and copy?) and understand the previous article showing how to replace the fuel transfer pump. By using the factory parts you'll not have to worry about special aftermarket parts that may not be available to complete the repair when the truck breaks down.

Better yet, consider the '98.5-'02 transfer pump relocation kit from Vulcan Performance and Geno's Garage that allows you to change-out the transfer pump in five-minutes or less. (Read more about this kit on page 72.)

Customer: What should I tell my friend with the '03 and newer HPCR engine?

GG: The HPCR fuel system is entirely different. First and foremost, the fuel transfer pump is of a different design than the fuel transfer pump on the 24-valve engine. Although we are early in the '03 and '04 engine's life cycle, there are not reports of widespread problems with this newly-designed transfer pump. For '05, the transfer pump has been moved to a unit located in the fuel tank where the pump pushes fuel to the engine rather than pulling fuel from the tank. On the HPCR engine, the fuel is pressurized by a gear pump and loss of fuel pressure from the transfer pump does not equal an expensive fuel injection system failure. The gear pump is not fully capable of pulling fuel from the tank, so should a transfer pump fail, the worst scenario is that the truck does not start due to loss of fuel prime. Should you spend money on a gauge to tell you that the truck is not starting?

Customer: Is there enough pressure to support higher horsepower settings with the '03-'07's fuel transfer pump?

GG: In Issue 47, page 60, "Technical Topics" authors Doug Leno and Joe Donnelly had this to say about the HPCR fuel system: "It is not the purpose of this article to repeat the multitude of experiments showing the limitations of the stock lift pump and low pressure fuel system. This series of tests was done simply to validate that the stock fuel system is sufficient for power enhancements delivered by the boxes we tested (100 horsepower and below). We found no stumbling, hesitation, or other performance problems using any of the tested boxes; the power was smooth and predictable. As for actually measuring low-side fuel pressure, we hooked up the boost channel of the SPA Technique EGT/boost gauge to an SPA pressure sender on the Bosch CP3 fuel pump inlet. For the most aggressive power increase we tested, the low-side fuel pressure dipped to a value that is nominally equal to atmospheric pressure (gauge pressure read zero). This means that the low pressure fuel system is at the limit of its capacity, and from this we concluded that for the power levels tested, the low-pressure fuel system was sufficient, although barely so. Zero gauge pressure simply means that the CP3 inlet is not drawing (or pulling) fuel under vacuum."

Okay, should you spend money on a gauge to tell you that the truck is not starting? Will you be increasing the engine's output by a number larger than 100 horsepower? I can't answer these questions for you. I can suggest a combination of parts (a fuel cap and a Westach gauge) to make the installation on a '03 and newer truck easy to do.

Go forth and make an informed decision.

24-VALVE TRANSFER PUMP RELOCATION KIT

In August '05 TDR writer Andy Redmond wrote in to tell about a Mopar retrofit kit for the fuel transfer pump used on '98.5 to '04.5 Turbo Diesel pickup trucks. The following are the highlights from Andy's e-mail. At the conclusion of his discussion I'll offer my opinion of the kit.

Robert, here are the highlights on the Mopar fuel transfer pump retrofit kit (05175538AA) with instruction sheet K6855481.

- The kit retrofits all '98.5-'02 Turbo Diesels. These trucks were equipped with a Carter electric fuel transfer pump. The kit includes all parts necessary to convert to a tank module mounted pump, very similar to the design on '05-up Turbo Diesels. Major items include a new fuel tank module, electrical harness, fasteners and fuel connection hardware and supplies.

A similar kit is also available for the '03-'04.5 Turbo Diesels that currently use a fuel transfer pump mounted on the rear of the fuel filter housing.

- It's best to order by VIN because slightly different modules fit different size fuel tanks (which can vary about 1-2 gallons on some models).
- Reason for retrofit: As the readers are aware, the infamous electric transfer lift pump design has been problematic and unreliable at best. The controversy concerns a transfer lift pump that must lift fuel (Dodge-only application) much farther than on other ISB applications. The Dodge application requires that fuel be pulled in excess of five feet. Contrast this to a ISB-equipped Freightliner FL50 truck with a saddle tank less than three feet from the pump inlet. Additionally, many VP44 injection pumps would likely have not suffered catastrophic failure had the transfer lift pump not failed or partially failed, which starved the injection pump of fuel and fuel cooling (lubrication). The design specifications on the Carter lift pump are very close to, if not exceeding, manufacturer specifications. I guess now we know what happens when a part is pushed to its design limits!
- The kit lists for approximately \$400. It likely requires about 4-5 hours of shop rate labor to install the kit. DIY's should likely add more time.
- Reliability is unknown, but Dodge must believe the design on the '05-up Turbo Diesels to be superior to the previous design.
- A possible negative would be if a failure of the new transfer pump (now located in the tank) is experienced, the additional labor required to drain/drop the fuel tank and service the module/pump assembly could be more expensive.

I have personal experience with one retrofit so far. My friend that works in Mopar wholesale parts has a '00 model, which we diagnosed with an inoperable transfer pump. One of his friends at the dealership, a technician, did the retrofit in a

couple of hours. Another feature is greatly reduced pump operation noise before the engine is started. Unfortunately, I was unable to take photos while it was on the hoist at the dealership to show harness wiring, routing, etc.

Although I'm a proponent of the popular FASS fuel system, this would be a runner up. As long as it proves reliable, I tip my hat to Mopar!

**Andy Redmond
TDR Writer**

Now, my opinion: NO! Do not retrofit your truck. In the preceding pages we've covered the replacement of this troublesome part. My answer to the question, "Do you have any suggestion's about transfer pump replacement for the '98.5 to '02 owners?" has not changed with the announcement of the Mopar retrofit kit (05175538AA).

First let's review the prprevious correspondence from Issue 48. "Okay, this is another of my favorite topics. Many TDR members have added aftermarket fuel pumps to work in tandem with or in lieu of the existing factory pump. The drawback to any aftermarket accessory is that the owner is now responsible for installation of the product, special parts and tools to support the installation, and parts necessary should the new-and-improved accessory fail.

"Admittedly, the original fuel transfer pump has been problematic. However, before I would recommend going the aftermarket route, I would suggest the keep-it-simple-stupid solution. Purchase a spare Cummins transfer pump. Yes, the part number has been superseded numerous times (the final kit number: 3990082; a 4943048 pump and 4025182 harness). The current price at a Cummins distributor is \$180. Next, read (and copy?) and understand the previous article showing how to replace the fuel transfer pump. By using the factory parts you'll not have to worry about special aftermarket parts to complete the repair that may not be available when the truck breaks down.

"Additionally, my suggestion for all 24-valve owners is the purchase and installation of a fuel pressure gauge.

"The 24-valve engine's VP-44 fuel injection pump relies on fuel from the transfer pump to keep the VP-44's internal parts lubricated and cool. A bad fuel transfer pump (and the transfer pump is known to be problematic) means a loss of fuel pressure to the VP-44 and often leads to the demise of the very expensive VP-44 injection pump. A fuel pressure gauge for a 24-valve engine is mandatory."

Andy mentions that, "a possible negative would be if a failure of the new transfer pump, now located in the tank, is experienced the additional labor required to drain/drop the fuel tank and service the module/pump assembly could be more expensive." Change the words "could be more expensive" to "would most definitely be more expensive." Add to the cost factor the realization

that an on-the-road failure (These failures do not happen as you're pulling into a Dodge dealership, do they?) is now an expensive towing bill or a major time-waster even if you have the tools to swap a fuel transfer pump on the side of the road. (Yeah, right, change it on the side of the road.)

My keep-it-simple solution of having a spare lift pump will be complicated by misinformation in the field. Owners are being told that they can no longer purchase the lift pump at their Dodge dealership.

Regardless of the story from Mopar, there is good news for '98.5-'02 owners from the rest of the parts aftermarket. The staff at Geno's was solicited to purchase the "Carter (division of Federal Mogul) F74213" or "FP Diesel part number 3990105 fuel transfer pump assembly with wiring harness" from a diesel injection shop. (Interesting how the 3990105 number matches the number sold by Cummins.) Furthermore, Delphi is offering a fuel transfer pump, part number FP923 at other diesel injection shops. The Delphi, FP923 box was opened and there was not a wiring harness included in their kit. If my memory is correct, the wiring harness is needed on '98.5 to '99 trucks, as the early pumps had the harness pigtail protruding from the pump. Without the harness extension, the wires would be too short and not reach the replacement part.

So, it looks like availability of a transfer pump for '98.5-'02 will not be a problem. However, availability of a replacement pump for '03-'04.5 owners is a major problem. Page 74 has the details.

One last item to consider: the devil you know is preferable to the devil you don't know. None of the TDR audience knows how good or bad the '05 fuel transfer pump will be. There is not yet enough time on the clock. Nor do we know the symptoms of impending failure. Nor do we know the high, low, and mid-point performance (in psi) of the '05 pump. Enough said?

As a side note, Geno's Garage has chosen not to sell the fuel transfer pumps. Although it would be no fault of the retail outlet that you may purchase the pump from, the possibility of an unhappy customer was too ominous.

Robert Patton
TDR Staff

24-VALVE ('98.5-'02 OWNERS)—WHAT TO DO?

The First Step: Buy a Gauge

If you are the owner of a '98.5-'02 Dodge/Cummins Turbo Diesel truck, it is mandatory that you purchase a fuel pressure gauge. A gauge allows you to monitor the fuel transfer pump's performance and correct a small problem before it becomes a big and expensive problem—the replacement of the VP44 fuel injection pump.

Mandatory. Buy a gauge.



That is right, a gauge. Do not trust the low fuel pressure idiot lights. Your gauge will allow you to watch fuel pressure trends. A light tells you it is too late...

So, which fuel pressure gauge should you choose? From listening to the guys at Geno's Garage, they recommend the Westach fuel pressure gauge. It is an electrical gauge. It is inexpensive and easy to install. The price is about \$75 for a Westach gauge; \$200+ for Autometer. Owners of the '00-'02 trucks will need a \$19 fuel pressure line to allow you to marry a fuel pressure sending unit to the fuel system.

Alternately you can purchase a mechanical fuel pressure gauge. This design will have a pressure isolator that is mounted under the hood. The isolator is an interface that keeps diesel fuel in the engine compartment; a glycol fluid fills the capillary tube that goes through the firewall into the cab and to the back of the gauge. Mechanical gauges go from \$130 to over \$180. Because of their complexity the mechanical gauge is not recommended. Owners of the '00-'02 trucks would need a \$19 fuel pressure line to marry the fuel pressure sending capillary tube to the fuel system.

Step Two: Whose Fuel Transfer Pump

This is the \$150, \$210, \$400, or \$650 decision. Starting at \$150: Purchase a spare Cummins fuel transfer pump (part number 3990082). Monitor the fuel pressure with your gauge and become familiar with how to change the pump at its location on the engine.

Moving to \$210: Purchase a spare Cummins fuel transfer pump. Purchase a transfer pump relocation kit for \$59 (Vulcan Performance/Geno's Garage), and move the transfer pump to an easy-to-access location on the truck's frame rail.



The benefits of relocation: the transfer pump is not subjected to continual engine vibration; the transfer pump is closer to the fuel tank and operates more like a pusher pump. Should the pump fail, the pump is very easy to access.

Moving to \$400+: There are several vendors that sell performance-type fuel transfer pumps. If you've made changes to the engine that have pushed your horsepower to over 300 you've likely already added one of these pumps. TDR writer Joe Donnelly discussed the FASS system (www.dieselp.com) in his Issue 54 column. Other vendors: Pure Flow Technologies (www.pureflowtechnologies.com); Glacier Diesel Power (www.glacierdieselpower.com); and Vulcan Performance (www.vulcanperformance.com) offer similar pump-only kits for the '98.5-'02 trucks. Alternately you can become a fuel systems engineer and source a Holley, Carter, Walboro, etc., fuel transfer pump from a variety of automotive catalogs and retrofit a pump to your truck.



Moving to \$650+: The price tag moves to \$650+ when you take the performance-type fuel transfer pump kit as offered by the vendors above, and add to that kit a mounting block that holds one or two additional fuel filters. In the quest for clean fuel and reliable fuel pressure, this is the utmost solution.

'03-'04.5 WHAT TO DO

I have a '03 Turbo Diesel. Recently (45,000 miles) the filter-mounted fuel transfer pump stopped delivering fuel from the tank. After a lot of looking around the Dodge mechanic was able to get the replacement pump supplied by Mopar. These replacement pumps are in very short supply, which leads me to think I am not the only one with this original pump problem. Am I correct, and can you give me any information on this?

Larry Durkee

My response: Larry, wow! In Issue 50, page 108 (November '05) John Holmes reported that the '03-'04 transfer pump failures would have to be fixed using the in-tank designed fuel transfer pump. After much research I have concluded you were very lucky.

I, too, have an '03 Turbo Diesel. The warranty period has expired. Your correspondence prompted me to call my Dodge dealer to order a spare fuel transfer pump. Yes, we've all been told by Dodge and Cummins that the '03 transfer pump redesign is better than the old '98.5 to '02 pump, but I wanted to be prepared.

Guess what? John Holmes wasn't joking. You *cannot* buy the engine-mounted '03-'05 transfer pump from Dodge. The old inventory has been scrapped-out. (Believe me on this—I tried to purchase 1150 units through Geno's Garage and was told about the scrap decision just prior to press time. The part number (5093135AA) has been superseded to the "module in the fuel tank" kit 68003869AA or 68003870AA at a price of about \$375. Labor to remove the fuel tank and install the kit...I'm guessing \$400+.

No problem. With my engine serial number in hand I called my Cummins distributor. Long-story-short, same answer: you cannot purchase the engine-mounted fuel transfer pump from Cummins. Their part number 3957922 is superseded by a \$95 conversion kit that is simply the seals, washers, screws, fittings and hose that go with the relocation of a pump into the fuel tank.

The old 3957922 was priced fairly at about \$150.

Call me cheap. Call me apprehensive, but the claims that the '05 and newer pump-in-the-tank is the greatest thing since sliced bread have not been substantiated by Father Time. Call me lazy. Call me incompetent. I do not want to drop my fuel tank to install the in-tank kit.

So, where can I find the obsolete 3957922? If not the 395722, what other options do I have?

Four weeks worth of research and I was no better off than when I started. My quest was not clouded by the need for better transfer pump performance. I simply wanted a cost-effective solution to a problem that could arise. Solve the problem and provide others with a fairly priced alternative.

Sure, I could go the aftermarket transfer pump route at \$400+, or the aftermarket transfer pump with single or dual fuel filters as a part of the kit at \$650+. And, as you know, there is the factory answer that would cost about \$850.

I could recite the numerous parts supercessions. I could send you on the same wild goose chase for the transfer pump that is used in other non-Dodge B-series engine applications. But, I'll save you some time; the part is made by Airtex and the part number is 3968188. The price is \$140. At Geno's Garage we found some brackets and had it ready for release as an alternative to the aftermarket and factory answers.

Then I called Cummins to place an initial stock order. You guessed it...nationwide backorder.

At this point I was exasperated. So I called Eric at Vulcan Performance (www.vulcanperformance.com). We discussed the cheap, apprehensive, lazy and incompetent man's options to solve the '03-'04.5 transfer pump problem. We tried to formulate an answer.

We discussed an inexpensive kit to relocate the fuel pump onto the frame rail underneath the truck. We discussed many aftermarket pumps that could be used in the new frame rail location—the Cummins Airtex, the old Cummins/Federal Mogal '24-valve design, Walboro, Carter and Holley. Then we agreed that none of these fuel pumps offer the '03-'04.5 customer a proven record of performance.

As a plug-and-play option I understand that Delphi offer a replacement. The part number is FP943. Several TDR vendors offer this unit: Geno's Garage (www.genosgarage.com), Diesel Injection (www.dieselinjection.com) and Scheid Diesel (www.scheiddiesel.com) are three locations that I am aware of. The retail price is about \$200.

I was pushed to consider the aftermarket. The installation requires hardware and fuel lines to relocate the transfer pump to the frame rail underneath the truck. Several TDR vendors and their dealers offer relocation kits and pumps in prices that range from \$400 and up depending on the pump's performance and whether or not you want additional filtration. Vendors that I am aware:

- Vulcan Performance (www.vulcanperformance.com)
- Diesel Performance Products - FASS system (www.dieselpp.com)
- Pureflow Technologies - AirDog system (www.pureflowtechnologies.com)
- Glacier Diesel Power (www.glacierdieselpower.com)

Also, there are many dealer outlets that offer these vendor kits. At this juncture the aftermarket is the cost-effective answer with the Delphi unit at less than \$200.

'05-'07 WHAT TO DO

Starting with the '05 model year the fuel transfer pump was relocated into the fuel tank. The overly simplistic answer to a fuel pump failure is to return to your dealership for a warranty repair.

Have you exceeded the 36,000 mile (or is it covered for 100,000 miles—I don't know) warranty period? Labor for an in-tank replacement will be expensive. The aftermarket vendors listed for your '03-'04.5 Third Generation brothers offer fuel transfer pump kits with "sippy straws" to bypass a failed in-tank unit. The price range is \$450 and up depending on the pumps performance and whether or not you want additional filtration.

Robert Patton
TDR Staff

5/2008 EPILOGUE—ATTENTION '03-'04.5 OWNERS

As you may have noted, I had hoped that the May 2007 fuel transfer pump article would be the final word on what owners would need to do to make the different year model engines bulletproof. Fortunately for the owners of '03-'04.5 trucks there is an update to their story. The article "The Ongoing Fuel Transfer pump Saga" is reprinted from TDR Issue 60, May 2008. So, '03-'04.5 owners (and there are about 300,000 of you out there) read-on.

FROM ISSUE 60: THE ONGOING FUEL TRANSFER PUMP SAGA (Or, Why Subscribe to the TDR?) by Robert Patton

Why subscribe to the TDR? 'Cause the following can happen to you, your family, or your friends. In a time of unknown, you'll need a solution. Here is the story.

Brother-in-law purchases your used truck. Brother-in-law is in your big city and ventures downtown. Brother-in-law calls from the side of the expressway located in the less desirable side of town. The truck will not run. He has not read the TDR.

You have.

You start with the basics.

What happened? – It just quit running.

Did you just fuel-up? – Nope.

Will it restart or is it completely dead? – It will run for a few seconds then it shuts off.

Okay, open the hood and find the fuel filter. Next bump the engine over and bring the key back to the run position. Do you hear the buzz of the fuel transfer pump? – Ah, okay, I did that and no buzz noise, just some clicking noises. By-the-way, what's a fuel transfer pump?

Arrg...Obviously brother-in-law missed the 12-page article in Issue 56 about fuel transfer pumps. Since this part (which is the Achilles heel of a fine Cummins engine) can lead to a compromising and perhaps expensive engine-down situation, you'll want to have a plan of action.

Don't think that the fuel transfer pump problem won't happen to you or someone you know. As you read in the Issue 56 article, it is not likely to cause the '94-'98 owners too much trouble, as their fuel transfer pump is a mechanical unit that fails gradually.

The '98.5-'02 owners: you desperately need to have a plan of action. There were about 450,000 trucks made in this series of 4.5 years. For these owners nothing has changed in the past year. You'll want to read (reread) Issue 56.

The '03-'04.5 owners: Previously it was thought that the revised electric fuel transfer pump for these trucks was a better design than the '98.5-'02 pump. Well, brother-in-law's transfer pump lasted 115K miles.

Armed with information in the TDR (and a \$180 towing bill), the brother-in-law has some new-found options.

Postscript to the Issue 56 article, Page 74, "'03-'04.5 What to do?"

As you've previously read, the Mopar and Cummins parts networks have deleted the replacement fuel transfer pump from their inventories. Issue 56 was written in April '07. At that time the only plug-and-play option was a part number FP943 that was offered by Delphi at a retail price of about \$450.

Since that time we have found that the FP943 pump is made by one source—the same source that made the pump for Mopar and Cummins: Carter division of Federal-Mogul. I can only imagine their surprise when Mopar and Cummins scrapped-out their inventories last spring. Lots of extra inventory?

Perhaps so. The same part is not only showing up in a brown Delphi box, it is now available in a white Fel Pro box. We've closely inspected the pump and its contents. They are the same. And, available in stock.

More good news...the price has substantially dropped. How about less than \$200?

For those that want a plug-n-play option (or spare part), there is availability at several vendors. Diesel Injection, Scheid diesel and Geno's Garage are locations that I am aware of.

So, '03-'04.5 owners it is time to purchase a spare. Be ready for the inevitable!

'03-'04.5 Fuel Transfer Pump Installation

Following the well-written instructions that were in the Fel Pro "M4089602" box, the installation went on and off without a hitch. The following is a combination of the instruction sheet directive and some common-sense tips.

- Push the cables and wiring to the side of the fuel filter to make the transfer pump easier to access.
- Crawl underneath the truck and slip a heater hose (5/8" inside diameter) over the existing fuel filter drain hose.
- Open the fuel drain valve at the fuel filter housing. Drain the fuel and close the drain valve.



Extend the fuel filter drain hose to save the aggravation of having the fuel drain onto the frame which is caused by the existing short drain hose.

- Back under the truck: Locate the junction of the truck's hard fuel line-to-rubber fuel line. Pinch the tabs of the quick disconnect fitting and remove the fuel line.



Pinch the outer tangs of the fuel line quick-fitting to separate the rubber hose from the hard fuel line.

- Back up top: Disconnect the electrical connector from the fuel transfer pump (the pinch-to-release is on the bottom of the connector).



Unplug the water-in-fuel sensor. Note how the wires and cables have been pushed to the side of the fuel filter.

- Remove the four 5mm hex head bolts that hold the transfer pump to the filter housing.
- Remove the transfer pump and confirm that the sealing O-ring is also removed from the filter housing.



Do not forget to remove the old O-ring. An O-ring on top of an O-ring doesn't work too well. Ask me how I know.

- Assemble the new components to match the routing of the existing fuel pump and fuel line.



With the old transfer pump and fuel line removed you can see the orientation of the new fuel lines and primary fuel filter.

- Install the new O-ring to the fuel pump. Install the fuel pump into the filter housing. Position the fuel pump and push into place.
- Install the four 5mm hex head bolts (61 inch-lbs.).
- Connect the electrical connector to the fuel pump.
- Back under the truck: Check to be sure that the orientation of the new fuel line matches the route of the fuel line that was removed. Snap the fuel line quick-connect onto its fitting.



The installed orientation of the new fuel filter.

- Do a double check of your work. It is time to start the truck. Bump the starter, but do not attempt a complete start cycle. Return the key to the run position and listen for the fuel pump to operate. it will cycle for 15-20 seconds. Repeat the bump/return to run technique for 4-5 cycles to be sure that air has been purged out of the engine's self-priming fuel system.

- Crank the truck and check for leaks.

You're finished.

I am pleased to report the success of this project and that '03-'04.5 owners have a replacement part from the aftermarket. This plug-and-play option means you don't have to use the factory suggested repair technique—drop the fuel tank (labor estimate \$300-400) and add the '05-current fuel pump kit that goes into the fuel tank (parts estimate \$400).

This article updates the 56 article. Thus, we add another chapter to "The final Answer, Perfect Transfer Pump" article.

Robert Patton
TDR Staff

Related TDR articles: Issue 56, "Fuel Transfer Pumps Revisited." This 14 page article covers '94-'08 fuel transfer pump replacement options and service techniques.

08/2009 Epilogue—Attention '98.5-'02 Owners

Tired of reading about fuel transfer pumps?

No doubt that you are and, if I have done my job as a writer, there is no doubt that you understand the important role the fuel transfer pump plays in the well-being of your expensive Bosch VP-44 fuel injection pump. The VP-44 injection pump has to have fuel pressure from the fuel transfer pump or it will fail in short order.

In your readings you may have also noted my frugal recommendations:

- Purchase and install a cost-effective fuel pressure gauge (≈ \$100).
- Purchase a spare factory fuel transfer pump and kept he pump, your tools and the instructions on how-to-change handy (≈ \$150)

In the fall of 2008 the folks at Diesel Performance Products (the makers of the Fuel Air Separation System or FASS) introduced a mid-price fuel transfer pump option for the '98.5-'02 owner. The product is called the Dodge replacement pump (DRP) and it sells for ≈ \$250.

Advertised as a direct replacement the installation should be simple. To test out that belief, the following is a pictorial showing how TDR writer Andy Redmond installed the DDRP. The text and pictures are from TDR Issue 63, pages 108-109.

FASS DDRP FUEL TRANSFER PUMP

by Andy Redmond

The '98.5-'02 Turbo Diesel's most unreliable component is arguably the fuel transfer pump. If the fuel transfer pump fails, the demise of the expensive Bosch VP44 fuel injection pump is imminent due to inadequate fuel pressure, volume and lubrication qualities provided by the diesel fuel. The Bosch VP44 pump is actually quite reliable if the fuel transfer pump performs properly.

The OEM pump is manufactured by Carter, a Federal Mogul company. It has endured many supersessions and design changes. Delphi Diesel has recently remarketed the Carter pump. Another company, AirTex, offers a replacement variant. Dodge's latest solution for this woeful design is to offer a kit to place the fuel transfer pump inside the fuel tank/module, as they have discontinued their original design. The Cummins parts network still offers a replacement pump, if you provide the correct part number.

The well-known aftermarket company Diesel Performance Products (DPP) markets the FASS line of fuel transfer pumps. FASS is an acronym for Fuel Air Separation System. Only two offerings were available until recently—the HPFP

(remote frame-mounted replacement transfer pump) and the FASS (remote frame-mounted pump with water separator and fine micron fuel filters). Most of their customers purchased these items as a fix-it-for-good solution at a cost of \$450-\$800 dollars.

However, many enthusiasts with a stock or mildly modified engine wanted an OEM-type replacement with good reliability and a more affordable price point; thus the release of the Dodge Replacement Pump (DRP). It attaches in the factory location on the driver's side of the engine. The price point is \$269 versus Carter's at \$180-\$200. Is this the ultimate stock replacement pump?

The following is a pictorial installation of the DDRP on a '00-'02 model year truck. The lift pumps are the same for the '98.5-'99 model trucks, but there is a slightly different fuel transfer pump outlet, fuel line plumbing and fuel filter assembly.



Photo A

It is not necessary to remove the fuel filter housing to replace the lift pump. The arrow points to a 17mm wrench that is used to remove a banjo bolt that holds a fuel line from the fuel transfer pump to the fuel filter canister.



Photo B

For clarity I went ahead and removed the fuel filter housing. You can easily see the following:

① the pump outlet pipe; ② the Deutsch electrical connector disconnected; ③ the fuel transfer pump inlet piping, with blue quick-disconnect fitting. The fuel transfer pump is attached to the support bracket with three nuts (13mm) and one inlet pipe bracket support fastener (10mm head). Those that have changed a few of these fuel transfer pumps know how frustrating it is for the 13mm nuts to loosen the studs. If the stud spins with the 13mm nut you have to go underneath the support bracket with a thin 7/16 open wrench to hold the stud to keep it from rotating. Look at photo C, item ① and you'll see what I mean.



Photo C

The old and the new. The inlet and outlet pipes are moved over to the DDRP unit when it is installed. The DDRP comes with a female Deutsch connector to plug-n-play into the factory wiring.



Photo D

The installed DDRP unit. The kit contents provide an inlet screen (144 micron) for the inlet banjo bolt. The pump is primed easily with WD-40. The unit is quieter than the OEM unit.

Andy Redmond
TDR Writer

FROM ISSUE 60: HOW DO YOU CHANGE THE FUEL FILTER: 2007.5-2009 TRUCKS

If you are an experienced diesel owner feel free to skip this article. But, be forewarned, the convention of the TDR is to add information to an article that will make it worth reading for the seasoned professional. Let's see what can be added to this simple project to validate the worth of your TDR subscription.

FUEL FILTER BASICS

You can browse through your Dodge Owner's Manual, you can preach the virtues of maintenance to your friends and your offspring, but nothing makes a lasting impression like practicing what you preach. Maybe I should rephrase this to read that nothing makes a lasting impression like not practicing what you preach. Admittedly, I'll end up replacing an entire assembly because of my lack of maintenance to a component part of the assembly. Just like running out of fuel when you're the driver...it's my fault and I end up taking the long costly road to correcting the situation.

The most delicate part of a diesel engine is the fuel injection system. Because of the extremely close tolerances, the fuel injection system cannot tolerate contamination. Contamination can cause damage and, at a minimum, erratic performance.

The majority of low-mileage fuel injection pump failures seen by Cummins' warranty research department are caused by trash in the fuel system. Considering that trash is not a defect in material and workmanship, the resulting repair can be an expensive lesson in fuel system maintenance. Replace the assembly or perform maintenance on a component part, the choice is yours.

In this issue our back-to-the-basics article will show you how to change a fuel filter on a 2007.5 to current model year engine.

On a one-to-ten scale, this maintenance procedure ranks about a two in difficulty. However, fuel filter maintenance is often overlooked as new-to-diesel owners don't realize that fuel filter maintenance is called for every 15,000 miles. After all, when was the last time you changed your gasoline-powered vehicle's fuel filter? Why only 15,000 miles between fuel filter changes with a diesel? The obvious answer, diesel fuel is less refined than gasoline and is more susceptible to contamination by water and microbial activity.

Additionally, to the diesel novice the job of changing a fuel filter can be intimidating. Influenced by diesel folklore, the novice is concerned that the injectors and/or fuel system will have to be bled of trapped air, a task that he does not know how to perform. And, as recently as the '98 model year, air (and an accompanying squirt of diesel fuel) had to be vented using the manual fuel lift pump purging the air from a bleed screw. With the '98.5 24-valve engine's electric fuel lift pump and self-venting fuel system, the bleedscrew/squirt of diesel problem went away. However, the I-don't-know-how intimidation factor remains.

As with the '98.5-'02 and '03-'07 trucks, owners of 2007.5 and newer trucks have a fuel filter system that has an electric fuel lift pump and is self-venting. For '98.5 and '99 owners, the fuel filter how-to was covered in Issue 25, pages 84-86. For '00-'07 owners, the how-to was in Issue 45. Now that we have established the need for fuel filter maintenance. Let's get started on the how-to section of this article for the newer '07.5 audience.

2007.5 and Newer Fuel Filter Change

First, let's present three tips that will save you time and aggravation.

- Purchase your fuel filters in quantity. This prevents the excuse that you could not change the filter due to a not-in-stock situation. Additionally, a spare fuel filter should be in your box of emergency parts that you carry inside the truck. You cannot predict when or where you might receive a bad fill of fuel.
- Extend the fuel drain hose. The existing drain hose is about 18" long and hangs directly below the fuel filter housing. When fuel is drained, it is difficult to catch because the drain hose is not easily accessible. To correct this condition, I slipped a three-foot length of 5/8" heater hose over the existing drain hose (perfect inside-to-outside diameter interference fit). Extend and tie-wrap your longer drain hose to a convenient drain location.
- Purchase a one-gallon *plastic* fuel container. Keep it filled with quality diesel and use the fuel to pre-fill your filter. *Do not* store diesel fuel in metal, zinc-lined cans: the diesel fuel reacts with the zinc and forms a goo that can clog a filter and damage a fuel injection pump

The advisability of pre-filling the filter was debated in Issue 43, on page 148. Caterpillar heavy equipment mechanic and TDR member Craig Hubachek maintains that this technique is a service no-no as it puts unfiltered liquids (fuel or oil) on the filtered side of the filter. The audience should use due caution if you use the pre-fill technique. Note that since the '98.5 model year, with the truck's electric fuel lift pump and self-venting fuel system, the self-priming nature of the fuel system make the pre-fill unnecessary.



Let's Begin the Fuel Filter Change

- First extend the drain hose.
- Position your newly-added drain hose in a location that is easy-to-reach and easy-to-catch. Open the drain valve and drain the fuel from the filter canister.

The drain handle is open. Unlike the '00-'07 trucks, when you open the fuel filter drain valve there is only a trickle of fuel. Instructions in the Mopar filter box will tell you to drain only about eight ounces. You'll be lucky if that much drains out.

Remove the water-in-fuel (WIF) sensor electrical connector from the bottom of the filter's plastic cartridge. The tang on the connector wires is pushed out and the connector wires and female socket can then be pulled downward. In shadetree fashion, I cut the tang so that the connector will be easier to remove in the future. I'll let you debate the merits of tang-cutting.

As I mentioned in Issue 59, page 42, the fuel filter is buried under a myriad of electrical wires, electrical relays and cables. The fuel filter is next to impossible to access.



I tried to access the filter from above—no way. An accepted field service practice on 4x4 trucks is to hug the front tire and come in from the side in between the gap in the plastic wheel-well liner and the frame. Two-wheel drive guys need to remove the 8mm screws that hold the fender wheel-well liner in place and drop the liner out of position.

For the truck's initial fuel filter service I chose the under-the-vehicle service technique and a strap wrench to remove the filter. I wish I had known about the Harvey Barlow technique (page 40).

Subsequent fuel filter changes can be done from above if you take the time to move the aforementioned electrical wires, relays and cables to the side. You will have to move the oil dipstick tube to the left and modify the bat wing to accept the new dipstick location.



Relocate the oil dipstick tube to the valve cover.



With one hand above and one hand below you can get to the fuel filter from above.



Modified "bat wing" with new dipstick location.

Once the fuel filter is removed, following the Mopar/Fleetguard directions is very easy. The next several steps are from the instruction sheet.

- A screwdriver blade and an upward pry will enable you to pop the fuel filter from its plastic cartridge. Remove the filter and inspect the filter and the cartridge for contaminants. Likely the filter is discolored and is black in color. No cause for alarm, the filter is doing its job.

There is cause for concern if you find lots-of-junk in the plastic cartridge. An accumulation of junk could indicate microbe activity in the fuel tank. Draining the tank and treating the fuel system would be the necessary service technique.

- Discard the old parts.
- Confirm that the used end seal is removed from inside the head.
- Wipe clean the sealing surfaces of the new O-ring and end seal inside the head.
- Install canister sealing O-ring and confirm the end seal is in place on the canister.
- Lubricate the canister O-ring with clean engine oil. Do *not* pre-fill the canister with fuel.
- Install to the point of first contact for canister-flange and head.
- Tighten the canister an additional 1/2-turn of rotation.
- Reconnect the WIF sensor electrical connection and ensure proper connection is made.
- Reinstall the drain hose.

It is now time to re-prime the fuel filter canister. With the key in the ignition, briefly bump the starter, but don't attempt to crank the engine. Let the key fall back to the run position. Listen for the electric fuel transfer pump to operate. It should hum for about 20 seconds. The transfer pump is located in the fuel tank so you'll have to either carefully listen or have someone crawl under the truck and listen. Repeat this bump-and-prime procedure four or five times. Now, the moment of truth...Crank the engine and let it run for 20-30 seconds. Check the filter area and confirm that no fuel leaks are present.

Restart your engine and you are good-to-go for another 15,000 miles.

Robert Patton
TDR Writer

THE HARVEY BARLOW METHOD

Those that frequent the TDR's web site are likely familiar with Harvey Barlow and his helpful post in the 6.7-liter area of the discussion forums. In early August Harvey discovered another (and perhaps easier?) way to change the 6.7-liter fuel filter. The following is Harvey's method.

Using this do-it-yourself tip it is not necessary to remove the left front tire or even the left front fender inner lining. As Patton suggests, you may want to spend some time from above and below tie-wrapping cables and wiring to make it easier to access the fuel filter.

From below the truck, reach up and disconnect the water-in-fuel sensor wiring plug from the base of the fuel filter canister. Again, as Patton suggests, you may want to de-tang the sensor wiring plug connector.

I like the idea of extending the fuel filter drain hose. Do so by slipping some 5/8" ID hose over the existing plastic hose, or remove the plastic hose and permanently replace it with a longer length of 3/8" ID hose. Loosen the drain valve on the bottom of the canister by twisting the 2" plastic "star wheel" counterclockwise and allow the canister to drain. As mentioned, you'll not be able to drain much fuel. Now for the tip-of-the-quarter: Using a 1/2" ratchet and a 1/2" extension long enough to reach the bottom of the canister, insert the 1/2" drive tip of the extension in the slot in the bottom center of the filter and back it out one turn. You can now remove the canister by hand from above or below, taking care not to spill the remaining fuel in the canister.



I'll bet you didn't know that there was a 1/2" drive indentation on the bottom of the filter canister.

The replacement canister contains a new filter element and the water-in-fuel sensor. Simply apply the supplied replacement O-ring to the male end of the canister and screw it in by hand. Hand tighten it. Reconnect the water-in-fuel sensor plug.

Cycle the key twice, just enough to bump the starter but do not turn the engine over. This will cycle the fuel transfer pump in the fuel tank to refill the canister.

Start the engine and test for leaks.

Record the date and mileage in your truck maintenance record book.

If your truck runs and doesn't leak fuel, you did good!
HBarlow

And the editor thought to himself, "Why didn't I discover the 1/2" drive indentation on the bottom of the canister?" As you inspect the canister you'll notice that is an off-only type indentation. Thanks, Harvey, for the tip.

Fuel Transfer Pump – '03 to Newer Trucks

WHAT TO DO ABOUT THE FUEL TRANSFER PUMP ON YOUR '03-NEWER TRUCK – OR – THE FOOL PUMP RETROFIT

What to do?

With greater and greater frequency the “What to do?” question is asked at least three times a day to the staff at Geno’s Garage.

I’ve overheard the conversation too many times. The Geno’s staff’s line of questioning, “Are you a TDR member?” allows them to skip the ten-minute lecture about how the '98.5-'02 fuel system is totally different than the '03-current HPCR fuel system.

TDR guys already know that the worst thing that happens if the transfer pump fails is that the '03-current truck won't start and/or run.

Wait, don't let me get sidetracked on '98.5-'02 vehicles. If you are new to the TDR and want to know about this sad story, see the TDR's [Turbo Diesel Buyer's Guide](#) (TDBG) at our web site. Read the entire article, “Fuel Transfer Pumps Revisited”

Now, back to the story: What should a good Boy Scout do to be prepared. After all, we've all read stuff on the interweb (misuse of terminology intended) about how the fuel transfer pump is going to fail on our '03-current truck.

Or is it?

Remember the reference I made earlier about the non-TDR member? Now the Geno's staff will have to educate the owner about the fuel transfer pump on the '03-'04.5 truck (transfer pump on the engine) and the '05-current truck (transfer pump in the fuel tank).

The location of the fuel transfer pump on the '03 and newer trucks has quite a bit to do with the advice that the Geno's staff gives to the customer. But, before I get into the specifics for the '03 and newer trucks, let's do a quick review of the fuel transfer pump recommendations of the Geno's staff for *all* year models of the Turbo Diesel.

A Quick Review

'89-'98, 12-Valve 5.9-Liter Engine

This engine has a robust, mechanical fuel transfer pump. Should the fuel transfer pump fail, it will not harm the Bosch VE or Bosch P7100 fuel injection pump. Replacement fuel transfer pumps can be purchased at Geno's, Cummins, or auto parts stores. Purchase a replacement and install it now. Keep the working pump as a spare and tools to allow you to change it if an emergency arises. The need to monitor the fuel pressure from the transfer pump to the fuel injection pump is minimal—no gauge needed.

'98.5-'02, 24-Valve 5.9-Liter Engine

This engine has a fuel transfer pump that is electrical. It is located on the engine next to the fuel filter. At best, its life span is marginal. Should this electrical fuel transfer pump fail, the lack of cool fuel to the expensive Bosch VP44 fuel injection pump *will cause the VP44 to fail*. Replacement OEM-design fuel transfer pumps can be purchased at Dodge, Cummins, or aftermarket locations. The Geno's Garage folks will not sell this pump to a customer. Again, it is a marginal design.

Geno's Garage and others offer the FASS Direct Replacement Pump (DDRP-02) for these trucks as well as complete FASS high performance pumps and pump/filter combinations. Purchase a replacement and install it now. Keep the working pump as a spare and tools to allow you to change it if an emergency arises.

'03-'04.5, HPCR 5.9-Liter Engine

This engine has a fuel transfer pump that is electrical. Its life span is 80,000 to 120,000 miles. Should this electrical fuel transfer pump fail, it will not harm the expensive HPCR/Bosch CP3 fuel injection pump. The Dodge and Cummins parts networks do not sell a replacement pump for these year model trucks. Instead they sell a kit (\$350-\$400) that changes the fuel pump's location to an in-tank design. Labor for this conversion can easily run another \$400. Do not allow this modification/repair/replacement to be done to your truck. When the pump is in the tank you cannot do a side-of-the-road repair.

Geno's Garage does offer a replacement fuel transfer pump for the '03-'04.5 trucks. It is part number FPD4089602 for \$179. They also offer FASS high-performance pump/filter combinations. The need to monitor the fuel pressure from the fuel transfer pump is minimal—no gauge is needed. Purchase an external transfer pump replacement and install it now. Keep the working pump as a spare and tools to allow you to change it if an emergency arises.

'05-'12, HPCR 5.9-Liter and 6.7-Liter Engine

This engine has a fuel transfer pump that is electrical. It is located in the fuel tank. However, unlike all the previous Turbo Diesel trucks ('89-'04) this transfer pump doesn't lend itself to a quick side-of-the-road repair. It appears to be a solid design.

Do you trust the in-tank design? I called one of my friends at the factory hot-line for problems. His response, "It has been since 2005 and the 'test of time' is somewhat complete. The in-tank design is a good one and we did not see warranty numbers that caused any concerns."

For me, that was/is reason enough to "not worry and be happy." However, in my further conversation about the fuel system, he was quick to emphasize (as have many of the TDR's writers in our discussions on injectors) that clean fuel is paramount to long injector life. Regular 15,000 mile fuel filter changes should be rigorously performed. Injectors are expensive (a minimum of \$350 each, \$2100 total) and, should you wish to add extra fuel filtration to the system, I can see that as a great precautionary modification.

There you have it, a reason to modify your truck! And, a reason to be a good Boy Scout.

The Fool Pump Retrofit – My Boy Scout Plan

Here is the Boy Scout plan. Using the tip from TDR writer David Magnoli (Issue 69, page 67) I will install a parallel fuel transfer pump setup on my 2010 "Mr. Schwarz" truck. A FASS single filter unit will become the primary fuel pump, the in-tank fuel pump will serve as the spare. Some brass ball valves, extra hose, a draw straw and fittings will keep me entertained for an afternoon of making modifications to the truck.

Before I go too far with this plan, let's take a look at the financials of the project: A) Replacement of the existing Dodge pump with a new part, #68058692AA, \$245; B) Replace the Dodge pump with a Mopar remanufactured unit, #RL079472AA, \$164; C) Altogether replace the Dodge pump with a FASS, single filter, Titanium system, \$550; D) Do the FASS Boy Scout project with a FASS, single filter, Titanium system plus a draw straw, and hardware and fittings to direct fuel flow from the chosen pump, \$625.

Now, time for commentary:

- A) Replacement with new part – Compared to the price of the Mopar remanufactured unit this option was \$80 more expensive. However, a search of the Mopar parts system shows the number is superseded to the reman unit, RL079472AA. Proceed to scenario B.
- B) Given the seal-of-approval input from my Dodge contacts and the affordable price of the Dodge reman unit, this option seems the most practical to me. Hindsight has 20/20 vision. However, with the transfer pump in the tank if the pump unexpectedly fails you cannot do a roadside repair. The Boy Scout dilemma: where do you draw the line?

C) If you are going to the trouble of doing this much work at this much expense, I would spend the extra \$75 for a draw straw, hardware and fittings and do the FASS Boy Scout project outlined in scenario D. Likewise if your transfer pump had failed and you wanted the extra filtration of the FASS and the peace-of-mind of the Boy Scout technique, spend the extra money: replace the failed Dodge unit *and* install the FASS. Proceed to scenario D.

D) I've done a bit of rambling to get to this point. As I mentioned in my commentary for item B, hindsight has 20/20 focus and if I were simply faced with a need to replace the transfer pump, scenario B is all I would do.

However, I was already in the middle of doing project D, before I learned about B. And, my factory pump is still operative, so I will be a diligent Boy Scout and have two pumps that I can choose from.

So, what did I learn in my quest to complete the Boy Scout project/scenario D? I think you can tell by the title that I made some mistakes—I'm thankful that I have an old car for alternate transportation. I'm thankful that I have a small workshop that is out of the weather. I'm thankful that I have a hydraulic lift.

I'm thankful for friends that can help with lifting and alignment. This is not a quick and easy project. But, if you must, take some time and learn from my experience and mistakes.

I could take you through the project with a step-by-step set of instructions—you know, "Before proceeding, remove the battery connectors at the battery terminals, put on your safety glasses, ear protection and hard hat, etc.," but I will assume you have the skill set to tackle the scope of this project. Likewise, it is much more entertaining to read about the editor's mistakes and tips learned doing the project than it is to read about the nut and bolt sizes. Here goes: mistakes and tips learned with the '05-'12 Fool Pump Retrofit.

Big Mistake

Big mistake: I've got this project 90% completed, only some simple wiring to do to switch from the FASS to the factory pump. Everything is buttoned up; the wiring and plumbing are set for the factory pump to operate. The truck fires up and it is off for a test drive and to fill up the fuel tank. With the tank filled up, I hop in to return to the shop and do the balance of the wiring. Oops, the fuel gauge does not move from its reading of near empty. "Shazam" was not the expression I used to convey my displeasure with my workmanship. I suspected what the problem was—the float for the fuel tank sending unit was stuck against the newly installed draw straw fuel inlet pipe for the FASS pump.

I was quick to suspect the problem, why was I not more careful in my reassembly?

Please learn from this key mistake. (Yes, the float was hitting the draw straw.)

Now that the truck has 30+ gallons of fuel (30 × 7.15 pounds = 215 pounds), I would not be dropping the tank any time soon.

However, my big mistake gives me the opportunity to tell you how to access the fuel tank by removing the truck's bed. You didn't think I was going to drop a 215+ pound fuel tank, did you?

And now, on the positive side, things I learned doing the Fool Pump Retrofit project.

What Did I Learn?

First, the obvious—there are two ways to tackle this project: drop the fuel tank from underneath the truck or remove the truck's bed for access to the fuel tank.

You are correct to assume that I have used both methods to access the fuel tank. And, rather than give just my opinion, I asked the three other guys that helped me in the course of this project (Geno's Garage staff members) which way they would choose to access the fuel tank. Wouldn't you know it, the vote was split 50/50.

So, for the two guys that did not vote like I did—well, they can start their own magazine.

Seriously, I'll try to give you the pros and cons of each method, but you'll easily note that my bias is toward removing the truck's bed for access to the tank.

Bed Removal

Pros:

- If you've never worked with those pesky fuel line clips this is the only way that you can get clear access to them.
- As mentioned, you do not have to be concerned with the amount of fuel in the fuel tank.
- Less time lying on your back.

Cons:

- You still have to go underneath the truck to mount the FASS unit and do the fuel line cutting and splicing.
- You need three (possibly only one if he and you are the strong types) other folks to help you remove the truck bed.
- More junk to have to remove and reinstall.

Bed Removal Tips

If there is a way to over-complicate a project, I can discover it. Long story—short version: I attached tie-down straps to the four corners of the truck bed and the four arms of my hydraulic lift. With the lift at full-up, the truck's tires would not quite go underneath the raised bed. Yes, I tried letting the air out of the rear tires. In "Three Stooges" fashion, a group of us finally got the bed high enough to clear the rear tires.

Our efforts to reinstall the bed were just as comical. Time spent needlessly fumbling around: about two-hours.

I am pleased to report that the bed went back on without scratches or dents. However, with my pride in check, I must report to you that the bed lift could have been done much easier. How so? With four guys, one at each corner, lift the bed. Next, walk backwards about two feet and rest the front of the bed on the rear tires. The back of the bed can be supported with a floor jack(s).

Somewhere else in this article I've mentioned that hindsight has 20/20 vision...

Tips for bed removal:

- Remove the tailgate to make the lifting of the bed easier. Again, my buddies tell me that two strong guys lifting at the wheel well arches can get the job done.
- The bed is held in place with six, 18mm bolts: two at the front, four at the rear. The bolts were assembled with Loctite. The front bolts are difficult to access and require that the plastic wheel well liners are removed.
- Remove the plastic wheel well liners to get access to the hose clamps that hold the fill neck/vent pipe onto the side of the truck bed. Don't forget to remove the nearby ground strap.
- Since you have to remove the wheels/tires to remove the wheel well liners, it is a great excuse to rotate your tires.
- Remove the truck's rear bumper (six, 16mm bolts) so that you can lift the bed upward and not scratch the lower part of the rear bed or the front of the bed at the cab.
- If you remove the truck's bed you don't have to worry about how much fuel is in the tank.
- With the bed removed you'll notice that there is a long horizontal plastic "snubber" that is attached to the truck's bed. From Issue 75, page 46, I learned that this snubber is on the bed to prevent errant tie straps from blowing down between the cab and bed, wrapping around the driveshaft and then bending the bed prior to the strap snapping. TDR members complain that the snubber catches grit and removes paint from the cab. Below is a picture of the snubber. I noted the scratched paint on my cab, painted it with undercoat paint and removed the snubber from my truck's bed.



The plastic truck bed snubber.



The abrasion at the cab.

Tank Removal

Pros:

- Less junk to remove and reinstall.
- Fewer people needed to assist.

Cons:

- You had better be familiar with pesky clips that hold fuel lines in place because the tank can only drop so far before the lines and electrical connectors are “out of slack.”
- Without a lift you will spend lots of time on your back. (I really would not do the tank removal method without a lift.)

Tank Removal Tips

Again, without a lift, I really don't know how you would do this project. Well, yes, I do know: you would either remove the truck's bed or you would jack the truck up as high as possible and spend the day going back-and-forth underneath the truck on a crawler or sliding on top of a sheet of cardboard. Not my idea of fun.

Tips for underneath-the-truck tank removal:

- Since you are doing this work as a FASS Boy Scout project you've already driven around until the tank was empty, right?

What, the truck still has half a tank of fuel? No problem, let's use the fuel transfer pump to remove the 15 gallons of diesel fuel.

Here's how: With my 2010 truck I learned that the 12-volt positive wire to the fuel transfer pump is blue with a red stripe. From underneath the truck intercept the wiring harness at the driver's door area, slice into the cover and locate the blue/red power wire. With a long wire fastened to battery positive you can crimp wires and turn the fuel pump on to drain the tank.



Intercept the wiring harness at the area of the driver's door and you can manually operate the fuel transfer pump.

Oops, turning the pump on solves only half of the problem. Where do you disconnect the fuel supply line? (This is a trick question.) Answer: don't over think this one. Simply open the fuel drain petcock at the fuel filter. And, if you've previously taken five minutes to extend the fuel drain line (see Issue 75, page 80) and the fuel will drain directly into a five-gallon jug(s)



Utilizing the fuel drain line extension tip from Issue 75 it is easy to drain the fuel tank.

- Alternately, you can insert a 1/2" thin-walled hose (it has to be a smallish hose to slip past the roll-over ball in the tank's fill neck) and siphon the fuel out of the tank.
- Once the fuel is removed from the tank it's time to remove the two tank straps and drop the tank to the ground. Not so quick... Go to the driver's side and remove the hose clamps that hold the fill neck/vent pipe to the fuel tank.
- In order to get access to the fill neck/vent pipe you may have to remove the rear tire/wheel and then remove the wheel well plastic liner. This is a great excuse to rotate your tires.
- Now, with a deep-well, 16mm socket, remove the nuts that hold the tank straps in place. Drop the tank low enough so that you can feel the clips that have to be pinched to allow you to remove the fuel supply and fuel return lines.



The pesky “pinch-in” clips that hold the fuel lines to the fuel pump assembly.

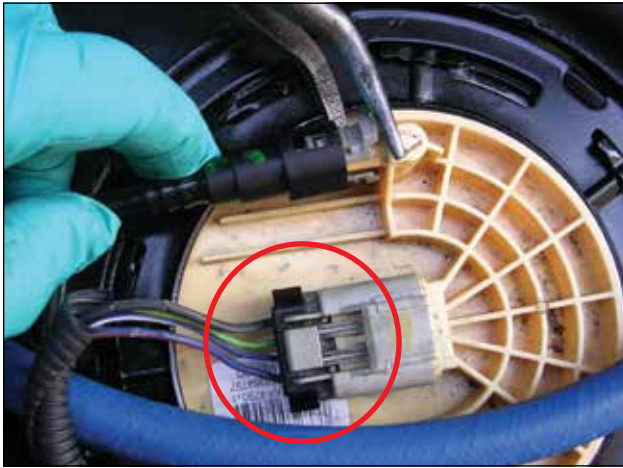

To remove the wiring harness you have to pinch down the grey tab to release the connector.

- You'll also have to disconnect the wiring harness for the fuel pump/fuel sending unit.



From this photo (yes, the bed was really removed) you can see how it all goes together.

- I've given you clear pictures of these fuel lines and electrical wires because you will not get a visual of these from the on-your-back vantage point. For a visual you'll need a flashlight and a mirror or you can take a peek from the driver's side wheel well.

- Drop the tank and slide it from underneath the truck for the necessary modifications: addition of draw straw, and the supply and return fuel lines.



Here is a picture of the tank that has been removed from the truck. Look to the front and you can see the location of the new FASS drawstraw.

General Notes

From some of the other photos, you may have noted the air horns, air tank and air compressor that I had already installed on the truck. Therefore, there was no room for the FASS unit. Wait...I have yet to use the floorboard storage compartments, so I removed the door and its compartment from the inside of the truck. I test fitted the FASS directly underneath the storage door. I fabricated a metal cover to protect the interior from the elements. I located the FASS or stock control switch on the metal cover.



From above, a picture of the FASS unit that I installed on the outside of the driver's side frame rail.



Open the driver's side rear floor compartment and you can see my FASS switch panel.



Stock valve is open, FASS valve is closed.

- I spliced some 3/4" heater hose and wrapped it around the new fuel lines to protect them.



The FASS unit from the underside.



Heater hose for fuel line protection.



The inside of the driver's side frame rail holds an air tank and air horns.

- With the air horns and the air tank removed, the next photo shows the plumbing of the FASS and stock fuel lines.

Conclusion

I learned quite a bit by doing this project. It wasn't difficult, however, it was time consuming. One last time, looking at it financially, it would cost \$164 to fix a failed factory pump versus \$625 to do this project. That's almost four times the money.

Yet, should either pump fail, I can continue my trip. and, with the FASS unit, I can rest assured that the fuel system is well filtered. Is the piece-of-mind worth \$461? For that answer I'll let you be the judge.

Robert Patton
TDR Staff

Low Pressure Fuel System Problems

by Andy Redmond

We all see much discussion on the TDR web forums and in the TDR publications regarding performance/drivability issues, which are often traced to a low pressure fuel delivery problem. Although the narrative that follows is specific to the 12-valve Turbo Diesel trucks, model year '94 to early '98 (pre 24-valve engine), the discussion on the components from the fuel tank (float and sending unit) to the fuel transfer pump apply to *all* Second Generation trucks.

The term low pressure fuel delivery system covers the components from the fuel tank up to the truck's fuel injection pump and from the injection pump back to the fuel tank. Common problems that will be discussed: fuel level sending unit; fuel heating element; fuel transfer pump; overflow valve; fuel return line.

Let's start at the beginning, the fuel tank. The fuel tank is approximately 34 gallons and made of an injection molded-type plastic material. The tank utilizes a fuel tank module with an integral fuel level sending unit. Carter (Federal-Mogul company) is typically the fuel tank module manufacturer; Walbro manufactures the sender. The module is installed vertically in the fuel tank and is retained by a large plastic nut and O-ring gasket to the threaded top of the fuel tank. The module has a lower half that can float up and down somewhat on a slide system. The purpose of the float is to prevent erratic fuel gauge readings due to fuel slosh when driving off-road. It also serves as a small basket, which will hold approximately one quart of fuel. This prevents air entrainment in the fuel system when the tank level is low and steep approach angles are tackled. The top of the module has ports for fuel supply (3/8") and fuel return (5/16"), a rollover valve/tank vent, an auxiliary fuel port and an electrical connector. The only serviceable parts on the module are the sending unit and the rollover valve and its grommet. The sending unit is notorious for the wiper contact area to wear out, which results in erratic fuel readings or fuel gauge malfunction. A sender-testing chart is shown should you desire to test your sender while the truck module is removed from the fuel tank.

Model Year of Truck	Sender Ohms at Full	Sender Ohms at Empty	Low Fuel Indicator Lamp (ohms)
'94-'97	0 +/-	100 +/-	65 +/-
'98-'02	20 +/-	220 +/-	PCM Function

Sometimes the use of an old-school analog multimeter will catch a dead or bad spot as the sender is moved up and down. The needle will falter or jump at the contact failure. Digital multimeters (DMM) are great tools, but my old analog meter still gets plenty of use for tasks like this. The DMM is constantly auto-ranging for accuracy in a specific reading versus the analog meter holding a steady reading. Now you have an excuse to purchase both types of multimeters!

Looking back in my TDR index, I see that members have been bothered by this problem since Issue 16 in the Spring of '97 when member Russell Caya did a how-to on fuel tank removal. Other memorable articles: Issue 26 where Mel Lang took the sending unit apart in an attempt to understand why it was/is problematic.

My look back at these old sources of information did not reveal a shadetree repair procedure. Perhaps the labor and time involved to remove the unit dictates that one should install a new sending unit rather than hope a repair would work.

Oops...I've gotten a bit ahead of myself. I've got you diagnosing the fuel tank sending unit, but I haven't given you some tips on removing the fuel tank, much less the fuel tank module which houses the sending unit. I prefer to drop the tank from the truck rather than lifting the truck bed. A tank with a couple of gallons can be a circus to balance, even with a large floor jack and a four-foot section of 2x12 or similar sized plywood, so it's nice to drain the tank. My "Rube Goldberg tank drainer" idea was first presented by TDR writer Joe Donnelly in Issue 37, page 45. "Unfortunately many of us have bed-mounted fuel tanks, toolboxes, fifth-wheel hitches, etc., making the bed-lift method impractical. In that event, run the fuel low, and remove the filler neck (it has a check ball in it so the hose won't snake down in to the tank). Put a piece of 3/8" hose into the tank, cut a whistle near the end, and blow air through the whistle with compressed air. This will start fuel flow and if your catch can is lower than the tank, it will flow until the tank is virtually empty."

Hard plastic lines (supply and return) of a quick-connect variety connect to the module and run along the frame rail (this plastic line mates to a metal or braided line on some models). The lines then mount onto a bell-housing bracket. Then they bend around the bell housing where a short length of 3/8" rubber fuel line provides a fuel supply to the fuel heater line that extends behind the fuel filter. Due to the age of the 12-valve truck, careful inspection is necessary from the tank to the fuel heater/strainer, to ensure that there are no leaks in the fuel lines.

I recall a discussion (Issue 44, page 32) where Brandon Parks at Geno's Garage had a lengthy battle with a hard-to-start '97 12-valve truck. After weeks of troubleshooting he did a close inspection of the metal fuel supply line coming from the tank as it turned upward by the firewall. A pin hole caused by years of chafing was the problem.



The module has metal pipes exiting the top of the module (supply and return) and has hard plastic tubing coils that extend to the bottom of the module where a removable screen covers the pickup and return. Most of them that I've dissected have a one-way check valve in the fuel pickup to assist in holding fuel prime. Many members have noted that these lines sometimes chafe and develop a pinhole, which allows for fuel aeration, not a good thing! The perforated tubing seems to have rubbed on a sharp edge, or on the mounting hardware for the lower float we previously discussed. The return also returns fuel to the bottom of the module (above tank bottom about 1/4"). This is preferable, as it allows returned fuel to be released into the remaining fuel rather than spraying on the tank's upper surface introducing foam and air.

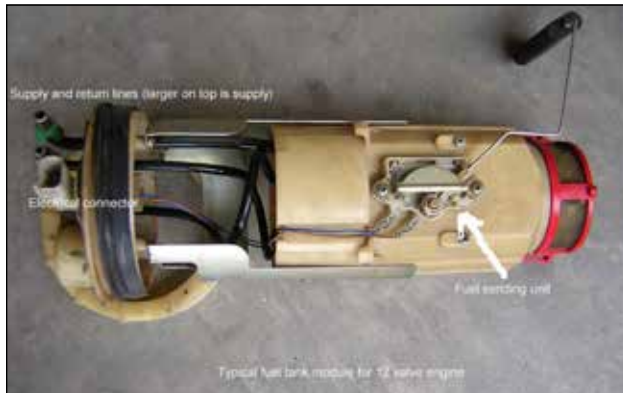

Permit me to further digress: I recently made a road call to visit a sick '95 model truck. The owner complained of a tapping noise and suspected connecting rod since the truck showed about 250,000 on the odometer. Over the phone when he held it near the source of the noise it sounded to me like a worn out lift pump tapping away on the cam lobe. The problem was missing fuel line routing brackets, which mount to the bell housing. It seems that the clutch had been recently changed and I assume the technician was speeding along attempting to "beat the book" (flat rate) and didn't see the need to attach the awkward brackets. The supply and return were chattering away on the bell housing which was driving its owner to near insanity. Some zip ties and split pieces of fuel line temporarily solved the problem while the replacement brackets were ordered.



Again, due to age, the fuel heater/pre-filter is a common repair area on 12-valve Turbo Diesels. TDR member Joe George showed us his method for finding a problematic air leaks at his fuel heater several issues ago (compressed air and a bucket of water). Joe's dilemma was much like Brandon's. Quoting from Issue 44, page 49, "I removed the fuel filter assembly (with the attached fuel heater and fuel pre-filter) from the truck. I applied 30psi of air to the assembly and lowered it into a bucket of water. Instantly, I observed a stream of bubbles rising from the fuel heater electrical connector. The connector had a crack in it, causing the lift pump to suck air into the fuel system. Without the removal of the assembly and the pressure test, I'm not sure I would have found this rare problem."



The fuel heater warms the fuel if the fuel temperature is below 40° and shuts off when the fuel temperature reaches 80°. The heater draws about 300 watts at 0°. This should help to prevent fuel gel in sub-zero climates. Should your fuel heater fail, it can be removed or eliminated. The pre-filter bowl is removed (using a short 17mm box combination wrench), and then a 8mm hex wrench is used to remove the shoulder bolt that retains it to the fuel heater casting. Once the fuel heater is removed the pre-filter bowl should spin onto the pre-filter base, the heater can be unplugged and you should be on your way.

The pre-filter assembly is attached to the engine block with the transfer lift pump cap screws. Fuel comes into the top of the unit via a short metal supply line, which attaches to the short length of 3/8" fuel line. It then passes through the

pre-filter screen, then the fuel heater then back out through a port and over to the transfer lift pump. This connection is made by a rubber supply line elbow that makes a sharp ninety-degree bend. I change this rubber elbow (item 11) when a transfer lift pump is serviced. Often this line is a major source of air leakage and subsequent fuel aeration.

As confirmation of my replace-the-elbow service technique, I had a discussion with a friend who is a competent technician. He had replaced a lift pump and now the truck would not restart. He stated that the lift pump would raise fuel up to the air bleed port on the fuel filter outlet, but with many bubbles rather than a clear stream of fuel. After we discussed probable causes, he called me back a short time later to report his findings. Sure enough, the rubber elbow was sucking air when the lift pump was manually primed. He also noted fuel weeping into the electrical connector on the fuel heater and a bad seal at the upper base and the upper heater "quad ring" (O-ring with square vs. round sides). Since he was short of parts, he removed the constant tension clamps and added gear-drive type clamps to the rubber line and removed the fuel heater and upper O-ring. After about twenty strokes on the primer and the truck started right up.

The next component, the heart of the low pressure fuel system for 12-valve owners, is the fuel transfer or lift pump. (Note to 24-valve owners: you can stop reading at this point. I don't want to discuss your electronic fuel transfer pump.) The lift pump is a piston style pump typically manufactured by Carter. It is designed to provide about 25psi to the fuel filter. It contains a manual primer and integral check valves that prevent prime loss and pressure delivery as fuel exits the pump. The pump is actuated by a plunger tappet, which rides on an eccentric engine camshaft lobe. Often as the pump ages the check valves wear and the plunger springs weaken. This can cause internal as well as external air and fuel leaks and a loss of fuel prime. Additionally, the fuel volume and/or pressure can diminish to a level which will cause sub-par engine performance. A healthy lift pump provides a volume of fuel far in excess of what the Bosch P7100 injection pump can use, with the exception being very high horsepower demands. At 400 rpm (starter motor cranking speed) for a thirty second cranking duration, the pump should deliver a volume of 20 oz. of fuel.

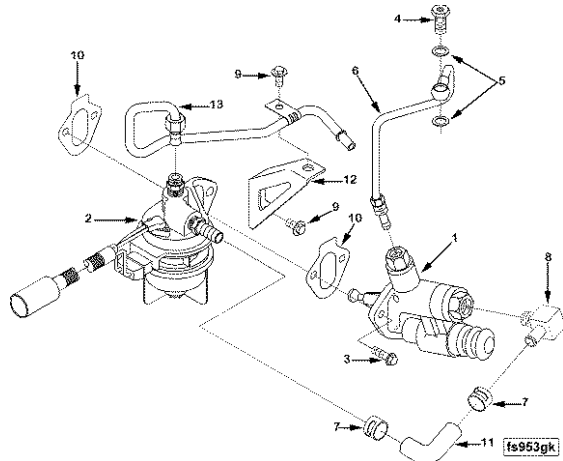

1998 12-valve illustration, part number 13 differs on 1994-1997 designs.

The fuel exits the lift pump through a metal tube to the fuel filter base inlet. It then is filtered and exits the outlet of the fuel filter assembly to travel to the injection pump. It is desirable to see 25psi at the fuel filter inlet. If you notice more than a 5psi drop across the filter (inlet to outlet) the filter is likely causing restriction. When testing the lift pump, should more than 4.0 inch Hg be shown on a vacuum gauge an inlet restriction exists somewhere back at the fuel tank. There are several things to watch for when servicing your fuel filter. The spin-on cartridge used in '94 to '96 vehicles (Fleetguard FS1253) has three O-rings that require attention when installing the filter: one on the re-usable water in fuel sensor, one that contacts the filter base and also one that fits onto the filter nipple. It's not a bad idea to check that the filter nipple is tight in the filter base with a hex wrench.

Fuel Filter	
1994-1996	1997-1998
Spin-on cartridge w/removable fuel drain/WIF (water in fuel sensor).	Drop-in cartridge. Filter cartridge canister housing contains a fuel drain and WIF sensor.

On the drop-in style cartridge used in '97 and '98 vehicles (Fleetguard 19578), the O-ring on the canister housing's threaded shaft (just below the brass bushing) is sometimes omitted from a filter kit. Should that be the case it is an acceptable practice to reuse the existing O-ring.

The fuel then travels from the filter outlet to the Bosch P-7100 fuel injection pump. This concludes the delivery portion of the tour of the low-pressure fuel system. However, several other items are worth mentioning on the return circuit of the fuel system. On the backside of the injection pump near the front corner of the pump is the location of the Bosch P7100 fuel pump overflow valve. This valve opens and allows fuel return to the fuel tank at approximately 22psi. When diagnosing fuel pressure problems, one can often determine if a lift pump or overflow valve problem exists by doing the following test. Let's assume we see a 12psi reading on our fuel pressure gauge. With the engine idling and a pressure gauge attached, slowly squeeze the rubber return line (this infamous rubber fuel return line is often



The Bosch P7100 over-flow valve.

problematic, but more on that subject in a minute) that runs behind the fuel filter. If the pressure gauge starts to rise, it means that the lift pump is making good pressure and that the overflow valve may be opening too soon. An overflow valve that opens at too low of a pressure will result in poor performance. Too much fuel will return to the fuel tank which robs the injection pump of fuel pressure that is necessary for proper operation. If the line pinch test makes little or no difference on the fuel pressure gauge, it would suggest that the lift pump is weak.

A drain manifold is available for excess fuel not injected by the six fuel injectors. The return path is sequential at each injector and returned to the fuel filter inlet. Usually these will leak fuel noticeably if a problem occurs, allowing the owner to quickly pinpoint the leak.

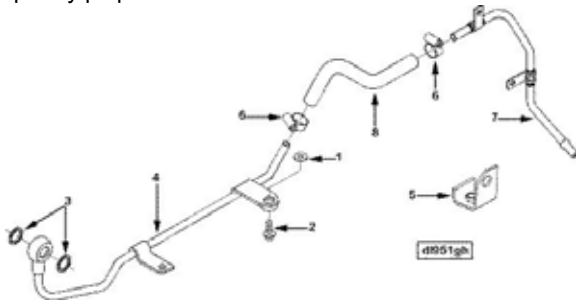

Notice the return line parts diagram: (illustration for 1998 12-valve). Part number 8, rubber fuel return line, is about three times as long on the earlier 12 valve applications. Also, part no. 7 is different as well.

Last, but not least (as evidenced by the numbers of problems that this hose has caused) is the rubber fuel return line. The illustration shows the rubber line used on a '98 12-valve. The '94-'97 trucks use a rubber line (5/16") that is about three times as long. The illustration is misleading. This hose is very difficult to see and access as it is tucked behind the fuel filter assembly.

Engine heat and age will cause this hose to develop cracks. It will leak air first, then fuel. Many owners report the use of a silicone grade marine fuel line as a permanent repair. I've had good luck as well with a Gates fuel injection hose, which seems to withstand the heat and elements far better than the factory-supplied SAE J 30R7, rubber fuel line. I find it helpful to remove the fuel filter base from the engine when changing the rubber return and/or supply lines. The lines can be gently slipped out of the brackets at the bell housing to provide better access. I also like to have a fresh razor blade handy to split the old lines where they are often stuck onto the metal fuel piping. Some fresh stainless steel clamps are smart too.

I will leave you with a list of part numbers that may help you in sourcing parts. Be advised that the part numbers may have been superseded.

Andy Redmond
Redmond Enterprises and Engine Repair
Plano, Texas

Common Part Numbers	Mopar	Cummins	Other
Lift pump	5012209AB	3936316	
Lift pump gaskets	5014230AB	3931059	
Injection pump overflow valve	4883838AB	3932096	2417413093, now ends in 101 (Bosch)
Gaskets for overflow valve	5015576AB	3935171	
Metal return line (ov. flow to rubber line)	4746641	3923171	
Fuel filter to injection pump (metal line)		3936691	
Rubber elbow (fuel heater to lift pump)	4883978aa 4746638	Not handy	
Sending unit (fuel) 1994-1997	04797738 or 05013467AA	N/A	N/A
Sending unit (fuel) 1998-2002	4897669AB	N/A	N/A
Roll-over valve (fuel module)	52127666	N/A	
Roll-over valve grommet	4002149	N/A	
Pre filter screen kit	4762962		3845400S (Fleetguard)
Fuel heater to heater base (upper)			3834185S (Fleetguard)
Fuel heater element			3907766S (Fleetguard)
Fuel heater harness			3843722S (Fleetguard)
WIF (water in fuel sensor) 1994-1996 only.			3831852-S (Fleetguard)

All About Exhaust Brakes – '89-'07 Trucks

MOMENTUM VERSUS THE EXHAUST BRAKE

A Look at Slowing Things Down

by David Magnoli

The theme of this issue is Momentum, and it is the perfect prompt as I had recently dealt firsthand with such force of motion and it made me realize how I have taken my exhaust brake completely for granted over the last several years. That is, of course, until it stopped working.

When I bought my 2001.5 truck it was a few years old and, for the most part, it was a stock truck that the former owner used to tow a 30-foot, bumper-pull travel trailer. That kind of weight can test the function of our brakes at any time, but when traveling on a long, steep downhill it becomes even more of an issue. Although the truck was stock in the power department, he wisely recognized that the addition of an exhaust brake was called for and added one to the truck. This being my first diesel vehicle, I was still getting used to the many differences between it and the gas trucks I had owned in the past, and I don't think I fully appreciated the exhaust brake fully at that time. I probably would not have gone out and bought one for myself, but after towing with it and using it pretty much all the time for the last several years, I would not want to be without it.

This past Fall when I was towing my trailer over the Sierra Nevada mountains, I had a problem with the electronic controller of my brake that caused the torque converter to not go into lockup when the brake activated, rendering the brake quite ineffective. Rolling down Tioga Pass towards the town of Lee Vining and US395 on that long steep descent, I really missed the ability to just release the throttle pedal, hear that reassuring growl, and feel the truck completely under control, slowing smoothly and confidently on any and all hills. After repairing the minor problem I had with the controller I decided to take a closer look at this simple, but very important, towing and safety accessory. Let me give you an overview of the exhaust brake that is used on the 5.9-liter engine from years '89 to '07. The '07.5 and newer 6.7-liter engines use a sliding vane in the turbocharger to create exhaust back pressure. Issue 70, pages 46-50, has the details for the 6.7-liter owner.

Exhaust Brake Principle of Operation

The reason we even have the need for an exhaust brake lies in one of the basic differences between a gasoline and a diesel engine. In a gasoline engine there is a throttle plate that closes off the intake air when the accelerator is released. When the pistons move downward on the intake stroke, they pull against the closed throttle and cause a vacuum to be created in the cylinder, slowing the engine by this resistance. Because of the closed intake, there is very little air in the cylinder on the following compression stroke so that the rebound of compressed air against the downward traveling piston is minimal. Because of this there is an overall slowing effect on the engine.

A diesel engine has no throttle plate and air is open to the atmosphere on the intake side, allowing it to be freely drawn into the cylinders whenever the pistons move down on the intake stroke. When the fuel pedal is released and the fueling stops, the engine freewheels, becoming a very large air pump with a minimum of any intake or exhaust resistance, thereby offering nothing but internal friction and the service brakes at each wheel to slow the vehicle down.

This leaves us at a disadvantage when compared to gas truck owners in a downhill situation because they have engine compression going for them, and along with proper downshifting they can more effectively keep the vehicle speed in check than we can, saving the service brakes from overheating and fading. But all is not lost in this for the diesel pickup crowd, for we do have a very easy and even more efficient solution to our diesel's lack of braking resistance. It lives over on the exhaust side of things.

An exhaust brake is, in its simplest form, nothing but a valve that closes off the exhaust when the throttle pedal is released, a mechanical potato-up-the-tailpipe as it were. It is often referred to as a butterfly valve but, in truth, it is a one-piece, round disc on a central pivot-arm that rotates within a close-fitting housing. With the potato-up-the-tailpipe turned on, the exhaust cannot escape and back pressure builds in the exhaust system. The engine is working against itself and, since it is directly coupled to the drivetrain (a manual clutch or an automatic with a lock-up torque converter), the vehicle slows down. The faster the engine turns, the more backpressure is created, and therefore the more braking effect is felt. But that compressed exhausted air cannot be completely blocked off, it has to go somewhere in a controlled manner so that the engine is not damaged, while still allowing the brake to do its job, and this can be accomplished in a number of ways.



Exhaust Brakes for '89-'07 Engines

There are several different brands of brakes available to us and they each use a different method of safely controlling and bleeding off of exhaust back pressure. Some, like Cummins/Jacobs, the Banks Brake on my truck, or early design Pacbrake units, use a fixed-size orifice in the butterfly valve that permits a measured amount of gas to escape down the tailpipe, but still allows enough compression of the exhaust gas to slow the engine effectively. This type of brake works best at higher engine RPM because it offers a set resistance determined by the size of the hole in the valve. At a higher engine speed, there is more backpressure and as such the brake resists more, but as this backpressure falls off with slower engine speeds, the fixed-size orifice in the butterfly allows that reduced pressure to bleed off more freely, resulting in a loss of slower-speed braking.

Others, like the BD brake, use a solid butterfly that is spring-mounted and regulated so that it varies the opening slightly as the pressure increases, bleeding off the needed amount of gas while still maintaining the optimal backpressure for a given RPM. As the RPM and pressure drop, the valve closes more completely, giving a more consistent braking effect as the engine and the truck slow down. This type is said to be more effective at lower engine RPM than the fixed-orifice type because it adjusts the bleed-off in a varying amount to match the pressure, giving better low RPM performance. Pacbrake's newest design uses a combination of these last two methods, with a fixed-sized orifice covered by a spring-mounted flap that does essentially the same thing by varying the orifice size to offer a variable-pressure braking effect through a wider RPM range.

When activated in the cold warm-up mode at idle, a loud hissing can be heard emanating from the exhaust tailpipe as the hot exhaust gasses are forced through the restricted brake butterfly. This is noticeably louder if you happen to have a straight exhaust. When activated while driving, it lets you know it is working by the smooth, deep-toned exhaust growl it generates as it does its job.

Regardless of which method is used to increase the backpressure, once the brake is closed and building pressure, all the exhaust paths in the head and the manifold system are exposed to this high pressure. Although not an issue on the newer 24-valve trucks, the older 12-valve trucks will need to have the exhaust-valve springs changed out to 60 pound springs to keep these forces, which are now on the back side of the exhaust valves, from opening these valves when the exhaust manifold is pressurized by the closed brake. You can get by without changing springs (the '89 to '98 12-valve engines were equipped with 35psi springs) if you use a brake with diminished capacity so as not to exceed the strength of the stock springs.

These brakes usually just have a larger hole in the butterfly to allow less backpressure, but that will also result in less braking force because you are limited to building only 35psi of back pressure. For the 12-valve owners that may be considering an exhaust brake and the possibility of changing the exhaust valve springs there is an excellent why-for, how-to, what-if article in TDR Issue 54, pages 30-36. Check it out on the TDR web site's magazine archives.



The Banks Brake on my truck is typical of turbo-mount brakes, replacing the stock transition elbow that connects the turbocharger to the downpipe. Being under the hood makes them less exposed to the elements than the inline models and also makes installation a simpler, bolt-on procedure. Mounting close to the engine also keeps the run of hoses to a minimum with less chance of damage. If you have twins or a non-stock single turbo though, this type is not an option.

The brake's cast-iron or stainless steel butterfly valve is mounted in a very close-fitting, machined cast-iron housing that attaches to the exhaust system in one of two places, depending on the method preferred. Most manufacturers offer both types to accommodate any owner's preference. The first type is mounted directly on the exhaust side of the turbo, replacing the cast-iron elbow that forms the transition between the turbo and the downpipe on a stock truck. This is usually a bolt-on system that is supplied with a new downpipe and is a fairly simple installation. I have this style on my truck and the only thing that can be considered a negative about it is that it limits the type of turbo you can use. If you wish to use anything other than a stock-type turbo, such as twins, or a high-performance single, you will have to go with the second type of exhaust brake installation.



This picture is of the Cummins/Jacobs version of a turbo-mount brake installed on a 2002 truck. The vacuum cylinder is smaller and is positioned down lower next to the firewall than the Banks version.

This second type of installation is an inline brake and it can be mounted anywhere on the exhaust, usually after the downpipe, but the closer to the turbo the better so as to reduce the volume of air that has to be compressed in use. Mounting further down the exhaust system would result in a delay in activation while the larger volume of air in the pipe is compressed to operating pressure. The installation of this type of brake requires some exhaust work, cutting and removing a section of the existing exhaust pipe and inserting the brake in that area with the supplied flanges, clamps and connectors. Because it is installed under the truck, this type is more routinely exposed to the elements and, as such, will require more attention than the under-the-hood turbo mounted brake. Maintenance on any brake is minimal, with some manufacturers supplying a lubricant for the main pivot bearing while others are completely maintenance-free other than to check the hoses and fittings for wear or leaks.



You can see that the inline, under-truck mounted exhaust brakes install in the exhaust pipe instead of directly on the turbo. They are a little more work to install because the existing exhaust pipe must be cut to allow the brake housing to be inserted. They are more exposed to the weather in this location. This one has the flanges nicely welded to the 4" pipe for a leak-free installation.

Now that you have the mechanical part of the brake installed you have to decide which method of activation you are able to use. Most of the brakes, regardless of mounting location, use either a "push" using a positive-air cylinder, or a "pull" using vacuum cylinder to activate the butterfly valve. In the default-off mode they have a very strong spring to return the valve to the open position and keep it there until called upon to activate and close. They use either a small air pressure cylinder or a large 2"-3" vacuum cylinder to activate the valve.



This picture shows a PacBrake installed on a First Generation, manual transmission equipped truck and is very similar to the Jacobs in the positioning of the air cylinder.

On the trucks with a factory vacuum pump the brake systems use this available vacuum supply to apply the force needed to close and hold the valve, but not all trucks have a vacuum pump nowadays. In this case you will need positive air pressure to power the brake and these brake systems often include a small air compressor and tank that will need to be mounted somewhere, usually under the hood, to supply the proper regulated pressure.

One exception to the air activation is U.S. Gear, which makes the D-celerator brake and as far as I know it is the only one that offers an electrically operated brake. Some manufacturers, such as Banks, supply as part of their kits, a small belt-driven vacuum pump for the '04.5-'07 trucks instead of an air compressor. Both air-based methods use an electrically-operated solenoid valve to activate the system and apply air pressure/vacuum as called for by the next important element of the system, the controller.

You could use a simple switch to activate the solenoid that controls the positive or negative airflow to turn the brake valve on and off, using it as needed whenever you chose to do so, but there is a problem with this simple method. If the brake valve were to be closed when you applied the throttle, the increase in exhaust pressure with no place to go could have bad results. It is for this reason that exhaust brakes are supplied with an electronic controller that will sense fueling and open the valve whenever you touch the throttle pedal. They are typically wired into the accelerator pedal position sensor (APPS), or throttle position sensor (TPS), or tapped into the PCM (Powertrain Control Module) or ECM (Engine Control Module) to allow you to leave the brake switched on without being operational until your foot is off of the throttle.

Some of the brake manufacturers have a connector that plugs directly into the OBDII port and reads engine/transmission function from that source. On older manual trucks without modern electronics, an on-off switch is installed, usually on the fuel pedal arm or out at the injection pump, that does the same thing. These sensors/switches also tell the brake when to engage by sensing when your foot is off the throttle. Now you have a simple switch that is able to turn the system on or off without worry. This brings us to the next control issue, the differences between how the brakes work on a manual or an automatic transmission.

I sometimes envy those of you with a manual transmission and the ease and effectiveness with which you are able to use the brakes on your trucks. You can use the brake in any gear you choose to, right down to first if needed. You can decide when to turn it on or off, at any speed or RPM and it obeys. Because the connection between the engine and the rear wheels is a direct couple, whenever the clutch is engaged, there is nothing to control except the throttle pedal/fueling sensor to make certain that the brake disengages when the throttle pedal is contacted. And because *you* control when the brake is on, it can be turned on manually to speed the warming of a cold engine, although some auto controllers do offer a cold warm-up feature also. You can also use an exhaust brake on virtually any year-model manual truck, something that is not true of an automatic.



Those with a manual transmission can use this gear shift with a switch at the top to turn on/off the exhaust brake. Trick, eh?

With us automatic guys it is entirely another story. Merely activating the brake when letting off the throttle would close the butterfly valve and restrict exhaust flow, but without a solid connection between the now-retarded engine and the rest of the drivetrain, driven by the energy of the moving truck, there is only a minimal braking effect. Our torque converter (TC) clutches are designed to release upon deceleration, causing the torque converter to just spin and create heat instead of connecting the vehicle's momentum to the now-restricted engine. The torque converter clutch needs to be locked in order to make the brake work effectively. This means that older automatic-equipped trucks (vintage '89-'93) with non-locking converters won't be able to use a brake on their trucks.

So along with the fueling sensor there has to be some way of locking up the torque converter (TC) clutch when the throttle is closed and the brake is activated by the controller. Most brake manufacturers offer a separate, additional controller for use with automatic trucks that monitors the PCM or the ECM to sense vehicle speed, fueling, torque converter clutch status, and forward gear status. If yours is a '94-'02 truck and you are interested in adding an exhaust brake to your vehicle, you're going to have to do some research because the electrical interface to keep the TC clutch locked up is not as refined as it is with Third Generation trucks. A suggested starting place, Issue 64, page 76. Pull out that back issue and you'll see that we owe a debt of gratitude to early Turbo Diesel pioneers and writers.

With 2003 (Third Generation) and newer models this additional lockup controller is sometimes combined in the same module with the basic controller. The 2006 trucks use the ECM itself to control the brake functions. These controllers will allow the brake to activate and the TC clutch to lock, but only when meeting certain pre-set requirements that are designed into the software. They will only allow the brake to engage above a certain speed or RPM, and in certain gears, and when slowing down will release the brake as well as the TC clutch, when a pre-determined vehicle speed, or RPM, or both, is reached, taking some of the control away from the driver and giving it to the controller. This is necessary because you would not want the TC clutch to remain locked when you come to a stop, this being similar to not disengaging the clutch when slowing.

Each manufacturer sets this lower limit as they see fit. Because transmission fluid line pressure is reduced when coasting, some brake manufacturers also include an air or vacuum cylinder and the associated hardware to increase the line pressure to make sure the torque converter clutch does not slip under the added stress of braking.

While on the subject of automatic transmissions, let's make things more complicated. Did you realize that Dodge does not officially support the use of an exhaust brake on any automatic truck before the model year 2006 due to concerns about transmission durability? Starting in 2006 they offered a brake installed and warranted from the dealer on these vehicles. There are, however, a lot of owners of the "unapproved" automatic-equipped trucks out there, myself included, that have been using a brake on our auto trucks for many years without any problems from such use. Most of these trucks are out of warranty anyway and the added safety of having an exhaust brake while towing far outweighs Dodge's concerns.

But, you may ask, isn't the automatic transmission from '03.5 to '07 the same unit, a 48RE? Yes, but the saga of exhaust brake approval by Dodge took until model year 2006. The final chapter to the story is found in TDR Issue 55, page 15.

Another issue with an automatic transmission concerns the matter of which forward gear you are able to use the brake in. In a stock truck (up to 2007 with the 48RE) the valve body setup only allows torque converter clutch lockup in overdrive and direct, or third gear. This means that the brake is most effective at higher vehicle speeds where the engine RPM is increased. Upon slowing, once you reach that pre-set minimum speed or RPM you will feel the brake release and you are back to the pedal to further slow and stop. When my 47RE transmission was stock I was only able to use the brake in these two higher gears; but with a modified valve body I can now switch off overdrive and manually downshift into second gear, and the brake remains activated and the TC clutch locked, raising RPM and allowing the brake to be engaged down to lower speeds. Some aftermarket transmissions/valve bodies will also allow a first-gear lockup. This results in the brake being far more usable at lower speeds by keeping the engine RPM up.

In 2004.5 you still have the overdrive-off option and at this time the tow/haul feature was added to trucks with the 48RE auto which, when activated, changes shift points and TC clutch lockup characteristics that will change the way the brake works when decelerating. The 2005 model years had tow/haul but no overdrive-off feature and then in 2006 and newer trucks with both tow/haul and OD-off were provided and still further change the way an exhaust brake will function depending on how these controls are used by the driver. As you can see, if you have an automatic transmission in your truck, there are several things that change the way a brake works; but these are, for the most part minor operational issues.

So far the basic functions of an aftermarket exhaust brake as I have been describing them apply to any year truck, but

in 2007.5 with the 6.7-liter engine, Dodge has eliminated the need for an aftermarket brake by supplying the engine with a VGT, or variable-geometry turbocharger. These turbochargers are able to internally vary the size and shape of the exhaust turbine housing in order to offer a wider and more effective turbo mapping range, offering more usable boost and better turbo spool up throughout all engine speeds. By way of a sliding nozzle ring within the exhaust turbine housing, the exhaust path can be varied and closed off to allow this turbo to become a very effective exhaust brake as well as a turbocharger. The great thing about this is that it is completely integrated into the truck's electronic controls and transmission systems for smooth and reliable operation. When used with the newer 68RE six-speed auto transmissions, with the tow/haul, gear selection, and OD-off controls, these newer trucks offer a brake that is much more tunable than the previous add-on models. Your Issue 70 magazine has the complete story on the VGT turbo.

Which Brake to Choose?

All the manufacturers will assure you that they have the best brake with the least amount of exhaust restriction when open and the strongest braking force when applied. They all claim the shortest stopping distances and offer proof in the form of colorful charts and graphs in their advertising to show how they are superior to the others out there in their quest for your business. I have never heard anyone really complain about their specific-brand braking performance; they all do the job well, and although I'm sure there are some differences, it can also be said that any brake is better than no brake. If you are going to seriously consider adding this very useful option to your truck, do your research and talk to other owners that drive the same truck that you have and then decide which one is best for you. There are certain model-specific restrictions on these brakes and each brand operates with slight variations with an automatic, so I would suggest that you do your homework to see what would work best for your particular application. Find the best option and get it installed, you won't regret this addition to your truck. Because while Mo-mentum is all well and good, sometimes you need a little Less-mentum, and an exhaust brake will give you just that.

References Please...

To simplify your research you need to start by looking at the TDR index that is (was) a yearly project by Bob and Jeannette Vallier. Key magazines you'll need: Issue 65, 61, 57, 53, 49, 45, etc. Turn to the column "TDRResource" and the title "Annual TDR Index." From there look up "Exhaust Brake" and you can read about the TDR writers' experiences with the installation of brakes on both manual and automatic transmission trucks. Read about the different exhaust brake designs from BD, Banks, Cummins/Jacobs and Pacbrake. Read about non-warranty approved usage of brakes with automatic transmissions. Read about the different ways to activate the brake with an automatic transmission. Read about modifications to the automatic to keep the transmission locked-up. All of the read-about will make the decision easier and help save your hard-earned money.

And, as a closing reminder, if you have a '94-'98 12-valve

engine don't forget that the exhaust valve springs should be changed so that you will have better performance of the exhaust brake. The chapter and verse for how to change the valve springs: Issue 54, pages 30-36.

David Magnoli
TDR Writer

DON'T CALL IT A JAKE BRAKE

Although "Jake brake" properly refers to the Jacobs brand of engine brakes, the term has become a genericized trademark and is often used to refer to engine brakes or compression release engine brakes in general, especially on large vehicles or heavy equipment. As we learned earlier, ours is not an engine or compression brake, but rather an exhaust brake.

On larger diesel engines with an engine or compression brake (not a potato-up-the-exhaust, exhaust brake like ours), an additional exhaust valve opens to bleed off this compression at the right moment so that its force is not returned to the engine. This system takes advantage of the piston working against the air in the cylinder to slow the rotation. Such a system is operated by a lobe on the camshaft and is designed as part of the cylinder head. Compression brake activation by the big-rig driver allows compressed air to escape from the cylinder prior to the injection of fuel and the power stroke is canceled. If you've ever driven beside a big rig when they activate their compression or "Jake brake" you know what the power stroke cancellation sounds like. Blahhhhhhhhhh, blahhh, blah, blah, rap, rap.

This compression-style brake was originally designed by Mr. Cummins. Mr. Cummins retired from Cummins Engine Company in 1957. However, he stayed active in the diesel business. In his book, "My Days with the Diesel" Mr. Cummins tells us the story about the development of the compression brake. "In addition to getting involved in a variety of new activities, including cattle ranching, I have proceeded with some important developmental work in the diesel field. Among these engineering advancements is a relatively simple accessory which converts a diesel engine into a highly efficient air compressor whenever vehicle retardation is needed. This 'engine brake' will hold a thirty-five ton truck under complete control (limiting speed to 19 mph) going downhill on a 10 per cent grade without use of the service brakes. Manufactured (under license) by the Clessie L. Cummins Division of the Jacobs Manufacturing Company (a subsidiary of the Chicago Pneumatic Tool Corporation), my diesel engine retarder already has been installed on thousands of trucks, eliminating for drivers the hazards of runaways and saving big money for operators in the form of reduced maintenance of the vehicles' conventional brakes."

And, now, you know the complete story behind the Jacobs brake (aka, engine or compression brake) and our little exhaust or potato brake.

Robert Patton
TDR Staff

DTCs AND YOU

You have got to love abbreviations. What is a DTC?

Better yet, what is a CEL, a SES, or an MIL?

DTC: diagnostic trouble code

CEL: check engine light

SES: service engine soon light

MIL: malfunction indicator light

All four abbreviations mean the same, there is some kind of a problem under the hood. But, how much of a concern should the glowing red light (GRL?) be to you? and, how do you retrieve the trouble code and determine its meaning?

As is the case with most things related to the Dodge/Cummins Turbo Diesel truck, our membership group has "been there and done that." Therefore the following is a collection of articles that I've arranged in a sequence for the best understanding.

- Issue 51: Author Sam Memmolo gives us background information on DTCs.
- Issue 55: Author Joe Donnelly discusses DTCs for '98.5 to 2007 vehicles.
- Issue 64: Editor Robbert Patton gives the audience an update on DTCs for the '07.5 and newer 6.7-liter engine.
- Issue 66: Author John Holmes tells us about the most common DTCs that dealership technicians encounter. This article also has a discussion about the severity, or lack thereof, of DTCs.

"DTCs and You," I am hopeful this collection of articles will shed some light (pun intended) on the subject. Seriously, tell your fellow Turbo Diesel owners about your new found understanding of codes and about the TDR magazine.

WHAT DOES THE CODE MEAN? Decoding your warning light!

Recently the TDR's editor called me and asked me to explain the trouble code quandry that many of us will face as we drive computer controlled vehicles. The call was prompted by an owner that had purchased a 2003 Dodge Shop Manual but was bewildered by the omission of the diagnostic trouble codes from the book. As a benchmark I consulted a '99 manual and was only able to see the code numbers and their meanings. A call to a Dodge contact revealed that the purchase of an additional 2003 Powertrain book (at 1300 pages) would be necessary to access the codes, their meanings, probalby cause, and action descriptives. Wow, that book would be another \$40. Worth it? At 1300 pages the book offers troubleshooting tests to help the technician trace the cause of the diagnostic trouble code. This information was not available in the 10 pages of codes in the old '99 book. So the question goes back to the truck's owner, "How much do you want to know?"

I'll try and help you sort through the DTC dilemma. But, first let's take a quick trip back in time before there were electronic engine and powertrain management systems. From the automobile's beginning the internal combustion engine was fueled with a mixture of air and fuel.

With stricter environmental legislation (circa late '70s), the manufacturers realized that mechanical engine fuel and spark controls were not reliable or durable enough to maintain the optimal 14.7:1 air fuel ratio, dubbed by engineers as stoichiometric. This 14.7:1 air fuel mixture is critical for proper operation of the catalyst in gasoline-fueled engines.

With the advances in microprocessor reliability, manufacturers decided that using electronics to control fuel distribution and spark timing would provide more efficient engine operation over a longer period of time, and thereby lower tailpipe emissions and provide better fuel economy as well as increased performance.

While electronic ignition provided a hotter, longer duration ignition spark at the plugs, it also dramatically reduced the need for periodic maintenance. Replacing points every 12 thousand miles or so became ancient history in a matter of a few years.

The early computer systems were basic, with very little intelligence, and provided little or no diagnostic functions. In 1981, GM introduced its first fully controlled system with diagnostic trouble codes. This was the GM or Computer Command Control system.

To alert the operator and the technician to a possible malfunction, a light on the instrument panel would illuminate. The first diagnostic trouble codes (DTCs) were now in place. The light initially read "Check Engine." That was confusing, so now many read "Service Engine Soon." This can still be misleading, because the light can illuminate when there is a transmission problem, a suspension problem, and even A/C and heater malfunctions.

The trade calls these "malfunction indicator lights" (MIL). Most '95 and later vehicles are controlled by the second generation computer systems called "on-board diagnostics II," or OBD-II.

There are many codes in use now as compared to just a handful in the early systems. OBD-II systems have much greater diagnostic ability, and can even track misfires down to an individual cylinder.

With this background information out of the way, let me suggest how the diagnostic trouble codes are of benefit to the "average Joe." First, just getting a scan tool and retrieving DTCs has never fixed a problem. Even if you have a reference manual that explains what the numerical codes mean, that is simply not enough to fix a car or truck. If it were, we would all be in much better shape.

If you experience a MIL illumination and/or a message in the driver information panel, the first step is to perform a good visual inspection. Step two would be to retrieve the trouble code using a scan tool. Once you have the code and get the definition, you are now ready to start troubleshooting.

Let's take this example: you are driving along and everything is normal. Then the dreaded MIL illuminates. You determine that the oil is fine, the coolant is okay, no belts or hoses broken, and no obvious signs of a major vacuum leak or any other problem.

You get the scan tool out and it tells you the code number. You look in the service manual, and the code refers to a defective exhaust gas recirculation (EGR) circuit.

Some would think that you could just replace the EGR valve, and bingo, the problem is solved. Not so easy!

The EGR or exhaust gas recirculation system is composed of several components: The EGR valve, the vacuum or electric source that supplies the energy to open and close (modulate) the valve, and the controls that allow the electricity or vacuum to flow to the valve. Some systems even have EGR sensors.

Not yet convinced that it is a complicated system? Add to all of the above the circuit in the microprocessor, the wiring and connections, the physical plugging up or carboning up of the EGR gas passages, and you have a treat in store when it comes to diagnosing the problem.

In order to properly diagnose and repair a problem signaled by the MIL's illumination, you will also need a diagnostic flow chart.

These diagnostic charts take you through a regimen of tests specific to the code. Step by step it directs you through a procedure that should bring you to a diagnosis and pinpoint the problem. Then you can effectively perform the repairs needed.

Diagnostic charts will not fix every problem, but they will teach you a tremendous amount about how that particular circuit works, and the possibilities of component failure.

So, the only way to accurately and professionally diagnose and repair the malfunction, without shot-gunning it with expensive components (which often cannot be returned to the parts house or the dealer), is to have a decent scan tool with the capability to interface with your particular application, and the appropriate manual with the diagnostic flow charts.

You may also need some additional equipment, such as a good digital multimeter, a hand operated vacuum pump, and even a heat gun.

From the scenario I have presented using an automotive EGR problem as an example you can see that the answer to "How much do you want to know?" is as unique as each

Turbo Diesel owner. The factory manuals are available (see Issue 50, page 51, and www.techauthority.com). The code number is easy to retrieve using the on-off-on-off-on technique that was described on page 10. There are affordable, good scanners available from Auto X-Ray and Actron. These devices are suitable for the do-it-yourselfer and work well. If you understand the system, follow the charts, and use a little common sense, you should be able to keep things humming yourself, and avoid the costly trips to the dealer.

Purchasing these tools, manuals, and electronic devices is not inexpensive, but when a club or a few owners get together and pool their resources, the cost becomes manageable. If you opt for an independent repair shop, be sure to question them as to what types of equipment and information systems they have in-house that apply to your vehicle. If they are not able to make you feel warm and fuzzy, be sure to check alternative shops.

Here are a few more tips.

The emission system warranty on most new vehicles (gasoline or diesel) is 80,000 miles. You should read your Owner's Manual and emission warranty information to see just exactly what is covered. You will be very surprised!

The other thing to keep in mind is to either fix the problem or have the problem fixed at the first indication, before the problem becomes into a big deal. I promise you, if you drive it with the light on, you are asking for trouble.

Happy Motoring!

Sam Memmolo
TDR Writer

CODES, CAUSES AND CONCERNS

I got together with Dario Scafidi, one of Carson Dodge's top diesel technicians, to try to outline the most common codes (out of the *hundreds* of them) that he and the other techs see frequently. The next question was whether it should be of concern to the owner or if you should not worry about it. One of the interesting things I ran into, from the technicians that had worked in other states, was how the frequency and type of code varies with different parts of the country. That makes sense because there can't be much greater contrast in environments than there is between our high desert location in Nevada and our Hill Country location in Texas. Altitude, temperature swings, humidity, fuel formulas, etc., all impact the vehicle's operation.

In general, if the check engine light is blinking, shut it down and get it directly to your dealer before doing further damage. If it stays on steady, better check it out and see if there's cause for concern. If it goes out after about five restarts, that generally indicates no reason for concern. (However, the code will still be stored in the PCM/ECM.)

The codes can (sort of) be deciphered as follows: P = Powertrain; B = Body; C = Chassis. On the second digit, it's either 0 = Standard or 1 = Manufacturer specific. Generally, the third digit breaks down this way: 1 = Emissions management; 2 = Injector circuit; 3 = Ignition; 4 = Auxiliary emissions; 5 = Vehicle speed and idle control; 6 = Computer and output circuit; 7 = Transmission.

The ones Dario highlighted on the 6.7-liter engines are:

- P1451- Diesel Particulate Filter System Performance (emissions – re-clean needed – maybe replace DPF);
- P2000 – NO_x Absorber Efficiency Below Threshold – Bank 1 (emissions - O2 sensors);
- P2002 – Diesel Particulate Filter Efficiency Below Threshold (emissions);
- P200C – Diesel Particulate Filter Over Temperature – Bank 1 (emissions);
- P200E – Catalyst System Over Temperature – Bank 1 (emissions);
- P2463 – Diesel Particulate Filter – Soot Accumulation (DPF full, possible regeneration or replacement).

As you can see, these all pertain to the emissions system and they should be checked right away to avoid expensive repairs or replacements. The other serious 6.7-liter code often seen is: P2262 – Turbocharger Boost Pressure Not Detected – Mechanical (flash, turbo clean or replacement).

Moving backward to the '03-'07 Third Generation, 5.9-liter, common rail diesels:

- P0148 – Fuel Delivery Error (restriction – fuel filter, transfer pump, injectors);
- P0191 – Fuel Rail Pressure Sensor Circuit Performance (flash);
- P0201 through P0206 – Fuel Injector 1 through 6 Circuit/ Open (engine miss – electrical, valve cover gasket);
- P0301 through P0306 – Cylinder 1 through 6 Misfire – (engine miss – mechanical);
- P0606 – Internal Control Processor (PCM failure – this one can also apply to the 6.7L);
- P0341 – Camshaft Position Sensor Performance – Bank 1 Sensor 1 (sensor, ECM, wiring or even a cam shaft).

The above items are important to get fixed, but P0514 – Battery Temperature Sensor Performance is a just a nuisance (flash). A flash will also take care of P0111 – Intake Air Temperature Sensor 1 Performance. An aftermarket performance box can set these: P0335 and P0336 – Crankshaft Position Sensor Circuit and Performance (no fix – light will eventually go out). Some units like to set P0513 – Invalid Skim Key (vehicle runs fine). Watch out for P0628 – Low Voltage Detected at Lift Pump (generally means the pump is going out – sometimes shows up on the 24-valves too).

Again, trotting backwards to the '98.5-'02 Second Generation 24-valve engines:

- P0216 – Injection Pump Timing Failure (bad news – may mean replacement – check transfer pump VOLUME, not pressure – fuel gauge can help prevent this);

P0234 – Turbo Boost Limit Exceeded (usually occurs with the use of a “boost elbow” on the turbo that comes with a power enhancement package – you'll have to live with it or go back to stock).

In the dealership, the technicians use a DRB III for trucks up through 2005. They use a StarScan, StarMobile or the new Witech for trucks 2006 and newer. These devices are specific Chrysler diagnostic tools and are pricey. Today the average owner can buy an aftermarket scan tool for a very reasonable price, although it won't be as sophisticated as those mentioned above. One example is the ScanGauge II that I wrote about in Issue 61, on page 88. However, that one does a whole bunch of things more than read and clear codes. Companies that make units of varying sophistication and pricing levels are: AutoXray; Actron; Equus Products, CarMD (check the Internet); and if you drop by Harbor Freight Tools you'll discover it's a good source for similar items. Any of the tool peddlers like Snap-on, Mac, Cornwell or Matco will also have similar types of scanners. Put this in your next letter to Santa.

John Holmes
TDR Writer

Editor's note: John's article on diagnostic trouble codes (DTCs) goes hand-in-hand with my article on DTCs in Issue 64, pages 46-49. In that article I listed the codes that are applicable for the 6.7-liter engine: how to retrieve the codes; how serious the code may be to you; and make it go away.

As a refresher, here is a reprint from Issue 64 on how to retrieve the DTCs.

What is an owner to do when you get the check engine light (CEL)/aka malfunction indicator light (MIL), or electronic throttle control (ETC) illumination on your dash? Better yet, what is the used truck owner, 10 years down the road, going to do? Can you say “black electrical tape?”

No, black electrical tape is not the answer. The answer is to find out what the dang-blasted DTC number is and look up its meaning. Then, make an informed decision about whether you will “drive thru” the diagnostic glitch or whether trouble looms on the horizon.

First, how do you retrieve the code? Internet myth has it that the codes cannot be brought-up on the '07.5 and newer trucks (some say since '06). On the flip-side, internet research will show you how to pull up the codes on a photobucket video.

I'll save you the time finding the photobucket video. The technique is the same as it has been since 1994. (I think it is that long ago.) Here is a diagram from your owner's Manual so that we're using the same words.

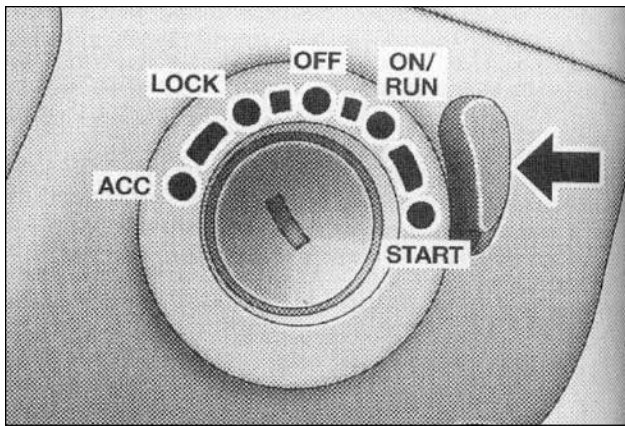

Using Dodge's vernacular, here is the method:

- Insert key
- Move it from Lock to Off, pause
- Move to On/Run
- Back to Off
- Move to On/Run
- Back to Off
- Move to On/Run and stop

The three movements from Off to On/Run should be done in less than, say, 5-seconds.

Read the codes where the truck's odometer shows total miles (not trip miles). Make note of the code(s) and continue your research as you look up the codes and their meanings.

The underlying question that neither John nor I have answered: "How serious is the code to the continuation of a trip to the convenience store or a cross-country journey?" The cop-out answer, "Mr. Turbo Diesel owner, it depends on the code and the nature of the problem." We do not know the answer.

My conclusion from Issue 64 remains the same...

What have we learned?

- In the future DTCs will continue in greater numbers and scope.
- You can retrieve DTCs using the "key trick."
- You have the codes listed in this magazine. Copy and carry them with you.
- You have a judgment decision to make should you encounter a DTC.
- If your problem is minor and does not reoccur the MIL light will turn off (foiur drive cycles) and the code will be cleared from OBD memory (40 drive cycles).

Editor's Update and Final Thoughts

If you flipped to this text (as directed in the discussion about DTCs on page 53) you can see that I do not have any further updates about 5.9-liter or 6.7-liter engine derate or damage implications to share with you. Author Holmes and technician Scafidi presented a good article on what codes are most common. Collectively we're

still looking for the answer(s) to how serious a code can be to the further operation of your truck. Today's conclusion is the same as it was in Issue 64: Each DTC has a unique meaning and each owner has to make a judgment call based on their situation, mechanical aptitude and tolerance for repair.

**Robert Patton
TDR Staff**

FUTURE ECM COMPLEXITY AND CURRENT DIAGNOSTIC TROUBLE CODES

In Issue 63's "Blowin' in the Wind" column there were quotes from the trade publication Transportation Topics that discussed future diesel emissions regulations. Titled "Ex-EPA Official Sees No New Rules on Diesel Exhaust Emissions After 2010," the article was examined for its meaning to the TDR audience. At the end of the quoted material from Transportation Topics I concluded the following: "In trying to interpret what the 'No New Rules' headline might actually mean for the 6.7-liter engine, I called one of my contacts at Cummins. What I took away from the phone exchange is the confident declaration that the engine is 'very well positioned.' The emissions from the 6.7-liter engine are on par with gasoline engines—and the emissions horizon for gasoline is stable. Reassuring. Nevertheless, the current notice of proposed rule (NPR) making has a deadline of 2013. The 2013 rules will have Dodge and Cummins further continuing modifications to meet on-board diagnostics (OBD) requirements. The bottomline...more sensors and greater ECM complexity as more engine parameters are monitored, controlled and reported through OBD read-outs. No rest for the weary."

Do you need further evidence of the greater ECM complexity and more items being monitored and reported?

Well you did not have to look any further than the summary of the latest technical service bulletin (TSB) 18-013-08 Revision A which was released in December and applies to all 6.7-liter engines produced prior to November 27, 2008. The summary was in Issue 63 on pages 38 and 39.

Did you miss the correlation of further diagnostics and the implementation of modifications on the 6.7-liter engine?

I'll save you from searching through your TDR library. Here is the text:

"Owners should also note that with the revised software of TSB 18-013-08 Revision A, a number of improvements have been made to the engine diagnostics. Performing this service bulletin completely will enable these diagnostic improvements.

- Improved Fuel Level Sensor diagnostics in the ECM.
- Improvement to the single diagnostic DTC P0148 – Fuel Delivery Error. This DTC is now addressed by the following two DTC diagnostics:
 - P1011 – Fuel Pump Delivery Pressure Too Low
 - P1012 – Fuel Pump Delivery Pressure Too High

- Creation of three new DTC's to address the inlet air temperature sensor separate from the ambient air temperature sensor. The new DTC's are:

P1191 – Inlet Air Temperature Sensor Rationality/Performance. This DTC enhances the current DTC P0071 – Inlet air Temp Sensor Rationality/Ambient Air Temperature Sensor Performance

P1192 – Inlet Air Temperature Sensor Too Low. This DTC enhances the current DTC P0072 – Inlet Air Temp Sensor Voltage Too Low

P1193 – Inlet Air Temperature Sensor Too High. This DTC enhances the current DTC P0073 – Inlet Air Temp Sensor Voltage Too High

- New ECM and CCN software that together will improve the customer understanding of the exhaust aftertreatment system messages that can be displayed on the overhead Electronic Vehicle Information Center (EVIC).
- Creation of a new DTC to address VGT actuator calibration event failures separate from other VGT actuator communication faults for P0046. The new DTC is: P003A – Turbocharger Boost Control Module Position Exceeded Learning Limit.”

6.7-Liter DTC Code Retrieval

Okay, we have laid the ground work for your understanding of the engine and exhaust aftertreatment's current and future complexity.

What is an owner to do when you get the check engine light (CEL)/aka malfunction indicator light (MIL), or electronic throttle control (ETC) illumination on your dash? Better yet, what is the used truck owner, 10 years down the road, going to do? Can you say “black electrical tape?”

No, black electrical tape is not the answer. The answer is to find out what the dang-blasted DTC number is and look up its meaning. Then, make an informed decision about whether you will “drive thru” the diagnostic glitch or whether trouble looms on the horizon.

First, how do you retrieve the code? Internet myth has it that the codes cannot be brought-up on the '07.5 and newer trucks (some say since '06). On the flip-side, internet research will show you how to pull up the codes on a photobucket video.

I'll save you the time finding the photobucket video. The technique is the same as it has been since 1994. (I think it is that long ago.) Here is a diagram from your owner's Manual so that we're using the same words.

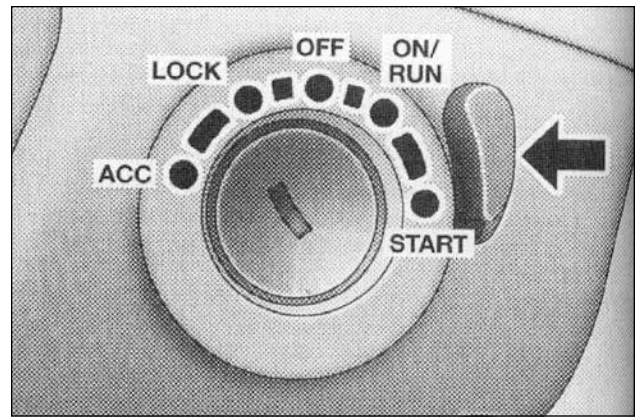

Using Dodge's vernacular, here is the method:

- Insert key
- Move it from Lock to Off, pause
- Move to On/Run
- Back to Off
- Move to On/Run
- Back to Off
- Move to On/Run and stop

The three movements from Off to On/Run should be done in less than, say, 5-seconds.

Read the codes where the truck's odometer shows total miles (not trip miles). Make note of the code(s) and continue your research with the TDR magazine in-hand.

What Do the Codes Mean

With apologies in advance to Chuck Berry (“No Particular Place to Go”)

*Ridin' along in my diesel truck
A code comes up, I'm outta luck.*

*What does it mean, well I don't know
Hoping the truck it doesn't slow.*

*I'll check it out when I get home
With no particular place to go.*

So, now I'm home and the computer is logged on to www.tdr1.com. My thanks to “Kilo” who posted the 6.7-liter engine code numbers and descriptions last October. The table:

P0016-crankshaft/camshaft Timing Misalignment - Bank 1 Sensor 1
P0031-O2 Sensor 1/1 Heater Circuit Low
P0037-O2 Sensor 1/2 Heater Circuit Low
P003a-Turbocharger Boost Control Module Position Exceeded Learning Limit
P0046-Turbocharger Boost Control Circuit Performance
P0049-Turbocharger Turbine Overspeed
P006e-Turbocharger Boost Control Module Supply Voltage Circuit Low
P006f-Turbocharger Boost Control Supply Voltage Circuit High

P0071 - Inlet Air Temp Sensor Rationality - ECM
 P0071 - Ambient Air Temp Sensor Performance (TIPM)
 P0072 - Inlet Air Temp Sensor Voltage Too Low - ECM
 P0072 - Ambient Air Temp Sensor Circuit Low (TIPM)
 P0073 - Inlet Air Temp Sensor Voltage Too High - ECM
 P0073 - Ambient Air Temp Sensor Circuit High (TIPM)
 P007C - Charge Air Cooler Temperature Sensor Circuit Low
 P007D - Charge Air Cooler Temperature Sensor Circuit High
 P007E - Charge Air Cooler Temperature Sensor Circuit Intermittent/erratic
 P0087 - Fuel Rail Pressure Too Low
 P0088 - Fuel Rail Pressure Too High
 P00AF - Turbocharger Boost Control Module Performance
 P0101 - Mass Air Flow Sensor "A" Circuit Performance
 P0102 - Mass Air Flow Sensor "A" Circuit Low
 P0103 - Mass Air Flow Sensor "A" Circuit High
 P0106 - Manifold Absolute Pressure Sensor Performance
 P0107 - Manifold Absolute Pressure Sensor Circuit Low
 P0108 - Manifold Absolute Pressure Sensor Circuit High
 P0111 - Intake Air Temperature Sensor 1 Performance
 P0112 - Intake Air Temperature Sensor Circuit Low
 P0113 - Intake Air Temperature Sensor 1 Circuit High
 P0116 - Engine Coolant Temperature Sensor Performance
 P0117 - Engine Coolant Temperature Sensor Circuit Low
 P0118 - Engine Coolant Temperature Sensor Circuit High
 P0128 - Thermostat Rationality
 P0131 - O2 Sensor 1/1 Circuit Low
 P0135 - O2 Sensor 1/1 Heater Performance
 P0137 - O2 Sensor 1/2 Circuit Low
 P0141 - O2 Sensor 1/2 Heater Performance
 P0148 - Fuel Delivery Error
 P0169 - Water In Fuel Detected For Too Long
 P0191 - Fuel Rail Pressure Sensor Circuit Performance
 P0192 - Fuel Pressure Sensor Low
 P0193 - Fuel Pressure Sensor High
 P0201 - Fuel Injector 1 Circuit/open
 P0202 - Fuel Injector 2 Circuit/open
 P0203 - Fuel Injector 3 Circuit/open
 P0204 - Fuel Injector 4 Circuit/open
 P0205 - Fuel Injector 5 Circuit/open
 P0206 - Fuel Injector 6 Circuit/open
 P0217 - Coolant Temperature Too High
 P0219 - Engine Overspeed
 P0251 - Injection Pump Fuel Valve Feedback
 P0300 - Multiple Cylinder Misfire
 P0335 - Crankshaft Position Sensor Circuit
 P0336 - Crankshaft Position Sensor Performance
 P0340 - Camshaft Position Sensor Circuit - Bank 1 Sensor 1
 P0341 - Camshaft Position Sensor Performance - Bank 1 Sensor 1
 P0381 - Wait-To-Start Lamp Inoperative
 P0400 - EGR System Flow Malfunction
 P0401 - EGR System Performance
 P0402 - EGR Flow Excessive Detected
 P0403 - EGR Control Circuit/open
 P0404 - EGR Position Sensor Performance Diesel
 P0405 - EGR Position Sensor Circuit Low
 P040B - Exhaust Gas Recirculation Temperature Sensor 1 Circuit Performance
 P040C - Exhaust Gas Recirculation Temperature Sensor 1 Circuit Low
 P040D - Exhaust Gas Recirculation Temperature Sensor 1 Circuit High
 P0420 - Catalyst Efficiency Bank 1

P042E - Exhaust Gas Recirculation Control Stuck Open
 P0461 - Fuel Level Sensor 1 Performance
 P0462 - Fuel Level Sensor 1 Circuit Low
 P0463 - Fuel Level Sensor 1 Circuit High
 P0471 - Exhaust Pressure Sensor 1 Performance
 P0472 - Exhaust Pressure Sensor 1 Low
 P0473 - Exhaust Pressure Sensor 1 High
 P0480 - Cooling Fan 1 Control Circuit/open
 P0483 - Cooling Fan Speed
 P0487 - EGR Airflow Throttle Control Circuit A Open
 P0488 - EGR Airflow Throttle Control Circuit Performance
 P0489 - EGR Control Circuit Low
 P0501 - Vehicle Speed Sensor 1 Performance
 P0505 - Engine Speed At Idle - Data Erratic, Intermittent or Incorrect
 P0513 - Invalid Skim Key
 P0514 - Battery Temperature Sensor Performance
 P0516 - Battery Temperature Sensor Circuit Low
 P0517 - Battery Temperature Sensor Circuit High
 P051B - Crankcase Pressure Sensor Circuit Range/Performance
 P051C - Crankcase Pressure Sensor Circuit Low
 P051D - Crankcase Pressure Sensor Circuit High
 P0521 - Engine Oil Pressure Sensor Performance
 P0524 - Engine Oil Pressure Too Low
 P0532 - A/C Pressure Sensor Circuit Low
 P0533 - A/C Pressure Sensor Circuit High
 P0541 - Intake Air Heater Control Circuit 1 Low
 P0542 - Intake Air Heater Control Circuit 1 High
 P0545 - Exhaust Gas Temperature Sensor Circuit Low - Bank 1 Sensor 1
 P0546 - Exhaust Gas Temperature Sensor Circuit High - Bank 1 Sensor 1
 P0562 - Battery Voltage Low
 P0563 - Battery Voltage High
 P0571 - Brake Switch 1 Performance
 P0572 - Brake Switch 1 Stuck On
 P0573 - Brake Switch 1 Stuck Off
 P0580 - Speed Control Switch 1 Circuit Low
 P0581 - Speed Control Switch 1 Circuit High
 P0585 - Speed Control Switch 1/2 Correlation
 P0592 - Speed Control Switch 2 Circuit Low
 P0593 - Speed Control Switch 2 Circuit High
 P0601 - Internal Memory Checksum Invalid
 P0604 - Internal Control Module Ram
 P0606 - Internal Control Processor
 P0607 - ECU Internal Performance
 P061A - ETC Level 2 Torque Performance
 P061C - ETC Level 2 Rpm Performance
 P0622 - Generator Field Control Circuit/open
 P0628 - Fuel Pump Control Circuit Low
 P0629 - Fuel Pump Control Circuit High
 P062C - ETC Level 2 Mph Performance
 P0630 - VIN Not Programmed In PCM
 P0633 - Skim Secret Key Not Stored In Pcm
 P063C - Generator Voltage Sense Low
 P063D - Generator Voltage Sense High
 P0642 - Sensor Reference Voltage 1 Circuit Low
 P0643 - Sensor Reference Voltage 1 Circuit High
 P0646 - A/C Control Circuit Low
 P0647 - A/C Control Circuit High

P0652 - Sensor Reference Voltage 2 Low
 P0653 - Sensor Reference Voltage 2 High
 P065S - Generator System Performance
 P0698 - Sensor Reference Voltage 3 Circuit Low
 P0699 - Sensor Reference Voltage 3 Circuit High
 P06A4 - Sensor Reference Voltage 4 Circuit Low
 P06A5 - Sensor Reference Voltage 4 Circuit High
 P0700 - Transmission Control System (MIL Request)
 P0850 - Park/Neutral Switch Performance
 P1011 - Fuel Pump Delivery Pressure Too Low
 P1012 - Fuel Pump Delivery Pressure Too High
 P1191 - Inlet Air Temperature Sensor Rational/
 Performance
 P1192 - Inlet Air Temperature Sensor Low
 P1193 - Inlet Air Temperature Sensor High
 P113C - O2 Sensor Power Supply Circuit Performance
 P125A - Power Enable Control Circuit Low
 P125B - Power Enable Control Circuit High
 P1272 - A/C Clutch Control Circuit 2 Low (TIPM)
 P1273 - A/C Clutch Control Circuit 2 High (TIPM)
 P1274 - A/C Clutch Control Circuit 2 Open (TIPM)
 P1275 - A/C Clutch Control Circuit 2 Overcurrent (TIPM)
 P1277 - Starter Control Circuit 2 Low (TIPM)
 P1278 - Starter Control Circuit 2 High (TIPM)
 P1279 - Starter Control Circuit 2 Open (TIPM)
 P127A - Starter Control Circuit 2 Overcurrent (TIPM)
 P127C - Fuel Pump Control Circuit 2 Low (TIPM)
 P127D - Fuel Pump Control Circuit 2 High (TIPM)
 P127E - Fuel Pump Control Circuit 2 Open (TIPM)
 P127F - Fuel Pump Control Circuit 2 Overcurrent (TIPM)
 P141A - Exhaust Gas Temperature Sensor 1 And 2 Signals
 Swapped
 P144E - EGR Cooler Bypass Status Line Circuit Low
 P144F - EGR Cooler Bypass Status Line Circuit High
 P1451 - Diesel Particulate Filter System Performance
 P1484 - Catalyst Overheat Detection
 P1506 - Crankcase Depression Regulator Valve
 Performance
 P1507 - Crankcase Filter Restriction
 P1508 - Crankcase Filter Restriction - Replace Filter
 P2000 - NO_x Absorber Efficiency Below Threshold - Bank 1
 P2002 - Diesel Particulate Filter Efficiency Below Threshold
 P200C - Diesel Particulate Filter Over Temperature - Bank 1
 P200E - catalyst System Over Temperature - Bank 1
 P2032 - Exhaust Gas Temperature Sensor Circuit Low -
 Bank 1 Sensor 2
 P2033 - Exhaust Gas Temperature Sensor Circuit High -
 Bank 1 Sensor 2
 P2080 - Exhaust Gas Temp Sensor Circuit Performance -
 Bank 1 Sensor 1
 P2084 - Exhaust Gas Temp Sensor Circuit Performance -
 Bank 1 Sensor 2
 P2121 - Accelerator Pedal Position Sensor 1 Performance
 P2122 - Accelerator Pedal Position Sensor 1 Circuit Low
 P2123 - Accelerator Pedal Position Sensor 1 Circuit High
 P2127 - Accelerator Pedal Position Sensor 2 Circuit Low
 P2128 - Accelerator Pedal Position Sensor 2 Circuit High
 P2141 - EGR Airflow Throttle Control Circuit Low
 P2142 - EGR Airflow Throttle Control Circuit High
 P2227 - Barometric Pressure Sensor Rationality
 P2228 - Barometric Pressure Circuit Low
 P2229 - Barometric Pressure Circuit High
 P2262 - Turbocharger Boost Pressure Not Detected -
 Mechanical
 P2266 - Water In Fuel Sensor Circuit Low
 P2267 - Water In Fuel Sensor Circuit High
 P2269 - Water In Fuel Condition
 P2299 - Brake Pedal Position / Accelerator Pedal Position
 Incompatible
 P242B - Exhaust Gas Temp Sensor Circuit Performance -
 Bank 1 Sensor 3
 P242C - Exhaust Gas Temperature Sensor Circuit Low -
 Bank 1 Sensor 3
 P242D - Exhaust Gas Temperature Sensor Circuit High -
 Bank 1 Sensor 3
 P242F - Diesel Particulate Filter Restriction - Ash
 Accumulation
 P244A - Diesel Particulate Filter Differential Pressure Too
 Low
 P244D - Exhaust Temperature Too High For Particulate
 Filter Regeneration - Bank 1
 P2453 - Diesel Particulate Filter Pressure Sensor A Circuit
 Performance
 P2454 - Diesel Particulate Filter Pressure Sensor A
 Circuit - Low
 P2455 - Diesel Particulate Filter Pressure Sensor A
 Circuit - High
 P2457 - Exhaust Gas Recirculation Cooling System
 Performance
 P245A - EGR Cooler Bypass Control Circuit Open
 P245C - EGR Cooler Bypass Control Circuit Low
 P245D - EGR Cooler Bypass Control Circuit High
 P2463 - Diesel Particulate Filter - Soot Accumulation
 P2503 - Charging System Output Low
 P2504 - Charging System Output High
 P2509 - ECM/PCM Power Input Signal Intermittent
 P254C - PTO Speed Selector Sensor Circuit Low
 P254D - PTO Speed Selector Sensor Circuit High
 P2579 - Turbocharger Speed Sensor Circuit Performance
 P2580 - Turbocharger Speed Sensor Circuit Low
 P2609 - Intake Air Heater System Performance
 P268C - Cylinder 1 Injector Data Incompatible
 P268D - Cylinder 2 Injector Data Incompatible
 P268E - Cylinder 3 Injector Data Incompatible
 P268F - Cylinder 4 Injector Data Incompatible
 P2690 - Cylinder 5 Injector Data Incompatible
 P2691 - Cylinder 6 Injector Data Incompatible
 P2a00 - O2 Sensor 1/1 Circuit Performance
 P2a01 -)2 Sensor 1/2 Circuit Performance

What is Next?

Okay, it is decision time. Let's say you've noted a "P0116 – Engine Coolant Temperature Sensor Performance," or P0071 – Inlet Air Temp Sensor Rationality – ECM." Are you going to "drive thru" the diagnostic glitch and feel comfortable that you'll not be stranded in Boondocks, New Mexico?

Were it my truck I would continue onward. But, as you can see by the different code definitions, there are some that will require your immediate attention. For that matter, the above P0116 and P0071 example that I would drive-thru may cause you too much alarm. If left unattended I've no doubt that the malfunction(s) will have other cause/effect

consequences. But, driving thru a DTC and the malfunction indicator light (MIL) or electronic throttle control (ETC) is not something that has an easy yes or no answer. Ultimately it is your judgment call.

For help with that judgment call I looked up both the MIL and ETC meanings in my Owner's Manual. Unfortunately, the text is just as vague as my judgment call response.

"If this light comes on and remains on while driving, it suggests a potential engine control problem and the need for system service.

"Although your vehicle will usually be drivable and not need towing, see your dealer for service as soon as possible.

"CAUTION!

"Prolonged driving with the MIL on could cause damage to the engine control system. It also could affect fuel economy and drivability."

The Seriousness of the EVIC

Say what? Yes, "seriousness," I have made up a new entry in the Webster Dictionary. And EVIC was defined earlier as an acronym for the overhead electronic vehicle information center (EVIC).

If you will look back at Issue 63, pages 38-39, you will find TSB 18-013-08 Revision A dated 12/04/08 which describes a reflash for '07-'09 DH/D1 (that's Dodge-speak for 2500/3500 pickup) trucks.

If you will look at our summary of TSB 18-001-09 you will see that there is another reflash program for the 6.7-liter engine that is used in '07 - '09 DC/DM (Dodge-speak for 3500/4500/5500 Cab and Chassis) trucks.

These two TSB revisions use the overhead EVIC to warn the owner of "Do Not Pass Go/Do Not Collect \$200" messages that will disable the engine due to emissions related problems. For examples of these messages, see the sidebar that we are reprinting from Issue 62.

All vehicles built after March 2008, or those fully updated per TSBs 18-013-08 and 18-001-09, have the software for the new messages that will appear on the EVIC should there be emissions problems.

The EVIC display of an impending engine problem is serious news and owners should take *immediate* corrective action at a Dodge dealership.

Make It Go Away

Will your DTC simply go away? Sure, that's what black electrical tape is used for. Seriously, look back at TDR Issue 61, page 88, and John Holmes' write-up on an inexpensive scan tool/monitor system. Purchase the Scan Gauge and clear the fault. It will work on automobiles too. Go to your local mechanic and clear the fault. Go to the auto parts store

and clear the fault... Clear the fault, but does it reappear? Time for a trip to the Dodge dealership?

Will the DTC go away on its own? Perhaps. A look at the industry-wide guidelines for on board diagnostics (OBD) reveals that it takes four drive cycles of non-malfunction to turn off the MIL light, 40 cycles and the code is cleared from the OBD memory.

Did it go away?

Conclusion

What have we learned?

- In the future DTCs will continue in greater numbers and scope.
- You can retrieve DTCs using the "key trick."
- You have the codes listed in this magazine. Copy and carry them with you.
- You have a judgment decision to make should you encounter a DTC.
- If your problem is minor and does not reoccur the MIL light will turn off and the code will be cleared from OBD memory.

Robert Patton
TDR Staff

Notes on exhaust system regeneration:

The ECM continuously monitors the level of particulates (soot) and other substances in the exhaust aftertreatment system. As needed, the ECM triggers a regeneration to remove them. This is completely transparent to the driver. There are no indicators on the instrument cluster or EVIC, and there is no difference in sound or feel of the engine. In other words, when things are operating as normal, as they do for the majority of owners, you will not know that a regeneration is needed or in-process.

In rare cases, typically due to difficult drive cycles, a regeneration may not be possible. In those cases, you may see a message on the overhead console (EVIC) regarding the aftertreatment system, stating either 'CATALYST FULL' or 'EXHAUST SYSTEM REGENERATION REQUIRED NOW', depending on the level of software. As long as the percent-full message is less than 100%, the system can complete a regeneration if you change your drive cycle to allow it to happen. The most effective drive cycle for regeneration is highway cruise. Some trucks, depending on the level of software, will display 'REGENERATION IN PROCESS' if your drive cycle has changed such that regeneration has been started. Note that this message will occur only after the system has gotten full enough to display the 'EXHAUST SYSTEM REGENERATION REQUIRED NOW', meaning you will not see it on every regeneration.

A visit to your dealer is necessary only if a message regarding the exhaust aftertreatment system reading 'SEE DEALER' or 'SERVICE REQD' is displayed on the EVIC. In that case, getting the truck to the dealer sooner, rather than later, may prevent further damage to the system.

OBD-II DIAGNOSTIC TROUBLE CODES FOR 1998-UP TURBO DIESELS

In TDR Issue 51, Sam Memmolo referred to these codes (page 91) as did John Holmes (page 107). John noted that you can't pull up the codes on your odometer with 2006 Turbo Diesels (Issue 52, page 42), although you can do so on earlier Turbo Diesels.

Here are the commonly used On-Board Diagnostic II Trouble Codes. They can be accessed on electronic odometers by cycling the key on-off-on-off-on.

P0112 – Intake Air Temperature Sensor Voltage Low
P0113 – Intake Air Temperature Sensor Voltage High
P0117 – ECT Sensor Voltage Too Low
P0118 – ECT Sensor Voltage Too High
P0121 – Accelerator Pedal Position Sensor Signal Volts Do Not Agree w/Idle Validation Signal
P0122 – Accelerator Pedal Position Sensor Signal Voltage Too Low
P0123 – Accelerator Pedal Position Sensor Signal Voltage Too High
P0125 – Engine Is Cold Too Long
P0168 – Decreased Engine Performance Due To High Injection Pump Fuel Temperature
P0177 – Water In Fuel Sensor Voltage Too Low
P0181 – Fuel Injection Pump Failure
P0215 – Fuel Injection Pump Control Circuit
P0216 – Fuel Injection Pump Timing Failure
P0217 – Decreased Engine Performance Due To Engine Overheating Condition
P0219 – Camshaft Position Sensor Overspeed Signal
P0222 – Idle Validation Signals Both Low
P0223 – Idle Validation Signals Both High (Above 5 Volts)
P0230 – Transfer pump Circuit Out Of Range
P0232 – Fuel Shut-Off Voltage Too High
P0234 – Turbo Boost Limit Exceeded
P0236 – MAP Sensor Too High Too Long
P0237 – MAP Sensor Voltage Too Low
P0238 – MAP Sensor Voltage Too High
P0251 – Fuel Injection Pump Mechanical Failure Fuel Valve Feedback Circuit
P0253 – Fuel Injection Pump Fuel Valve Open Circuit
P0254 – Fuel Injection Pump Fuel Valve Current Too High
P0300 – Multiple Cylinder Misfire
P0301 – Misfire Detected, Cylinder No. 1
P0302 – Misfire Detected, Cylinder No. 2
P0303 – Misfire Detected, Cylinder No. 3
P0304 – Misfire Detected, Cylinder No. 4
P0305 – Misfire Detected, Cylinder No. 5
P0306 – Misfire Detected, Cylinder No. 6
P0320 – No RPM Signal To PCM
P0336 – Crankshaft Position Sensor Signal
P0341 – Camshaft Position Sensor Signal
P0370 – Fuel Injection Pump Speed/Position Sensor Signal Lost
P0380 – Intake Air Heater Relay No. 1 Control Circuit
P0381 – Wait To Start Lamp Inoperative
P0382 – Intake Air Heater Relay No. 2 Control Circuit
P0387 – Crankshaft Position Sensor Supply Voltage Too Low
P0388 – Crankshaft Position Sensor Supply Voltage Too High
P0400 – Exhaust Gas Recirculation (EGR) Flow Malfunction

P0460 – Fuel Level Unit No Change Over Miles
P0462 – Fuel Level Sending unit Volts Too Low
P0463 – Fuel Level Sending unit Volts Too High
P0500 – No Vehicle Speed Sensor Signal
P0522 – Oil Pressure Voltage Too Low
P0523 – Oil Pressure Voltage Too High
P0524 – Oil Pressure Too Low
P0545 – A/C Clutch Relay Circuit
P0562 – Charging System Voltage Too Low
P0563 – Charging System Voltage Too Low
P0601 – PCM Internal Controller Failure
P0622 – Alternator Field Improper Switching
P0712 – Trans Temp Sensor Voltage Too Low
P0713 – Trans Temp Sensor Voltage Too High
P0720 – Low Output Speed Sensor RPM Above 15 MPH
P0743 – TCC Solenoid/Trans Relay Circuits
P0748 – Governor Pressure Sol/Control Trans Relay Circuits
P0751 – OD Switch Pressed (Lo) For More Than 5 Minutes
P0753 – Trans 3–4 Shift Sol/Trans Relay Circuits
P1283 – Idle Select Signal Invalid
P1284 – Fuel Injection Pump Battery Voltage Out Of Range
P1285 – Fuel Injection Pump Controller Always On
P1286 – Accelerator Pedal Position Sensor Supply Voltage Too High
P1287 – Fuel Injection Pump Controller Supply Voltage Low
P1291 – No Temperature Rise Seen From Intake Air Heaters
P1295 – Accelerator Pedal Position Sensor Supply Voltage Too Low
P1388 – Auto Shutdown (ASD) Relay Control Circuit
P1389 – No Auto Shutdown (ASD) Relay Output Voltage at PCM
P1475 – Aux. 5 Volt Output Too High
P1488 – Aux. 5 Volt Output Too Low
P1492 – Battery Temperature Sensor Voltage Too High
P1493 – Battery Temperature Sensor Voltage Too Low
P1594 – Charging System Voltage Too High
P1595 – Speed Control Solenoid Circuits
P1597 – Speed Control Switch Always Low
P1682 – Charging System Voltage Too Low
P1683 – Speed Control Power Relay Or Speed Control 12 Volt Driver Circuit
P1688 – Internal Fuel Injection Pump Controller Failure
P1689 – No Communication Between ECM & Injection Pump Module
P1690 – Fuel injection pump CKP Sensor Does Not Agree With ECM CKP Sensor
P1691 – Fuel Injection Pump Controller Calibration Failure
P1693 – DTC Detected In ECM Or PCM
P1694 – No CCD Messages Received From ECM
P1698 – No CCD Messages Received From PCM
P1740 – TCC Or OD Solenoid Performance
P1756 – Governor Pressure Not Equal To Target At 15-20 PSI
P1757 – Governor Pressure Above 3 PSI When Request is 0 PSI
P1762 – Governor Pressure Sensor Offset Improper Voltage
P1763 – Governor Pressure Sensor Voltage Too High
P1764 – Governor Pressure Sensor Voltage Too Low
P1765 – Trans 12 Volt Supply Relay Control Circuit
P1899 – PNP Switch Failure

Joe Donnelly
TDR Writer

Notes:

PROBLEMS SOLVED BY THE TDR'S WRITERS, TDR MEMBERS, AND TDR VENDORS.

I am always on the lookout for good ideas. Borrowing a "best tips" from Hot Rod and "problem solving" from Good Housekeeping, I asked the TDR writers to submit their tried-and-true advice for this issue of the magazine.

But, I did not stop there. I also sent the memo to the staff at Geno's Garage and we asked for input from vendors in the TDR magazine.

Finally, to make this article a compelling reason to continue your TDR membership, I did some research through old TDR magazines and through the TDR Buyer's Guide.

With the number of tips that we had, we organized them in the same manner as the folks at Chrysler use for their technical service bulletins.

2 Front Suspension	14 Fuel
3 Rear Axle	16 Propeller Shafts & U-Joints
5 Brakes	18 Vehicle Performance
6 Clutch	19 Steering
7 Cooling	21 Transmissions
8 Electrical	22 Wheels & Tires
9 Engine	23 Body
11 Exhaust	24 Air Conditioning
13 Frame & Bumpers	25 Emissions Control
	26 Miscellaneous

So, let's get started...

3 REAR AXLE

- TDR member John Holmes gives some tips for ensuring that rear differential lube is at the proper level following a differential oil change. Jack up each side of the rear axle for five minutes to ensure that oil reaches the axle bearings, then lower the truck to a level floor and check the fluid level. Add additional fluid as necessary to complete the fill. *John Holmes, TDR writer*
- On some trucks with heavy-duty suspension and overload springs, suspension noise from the overload springs slapping the frame stop can be annoying. Slip and tighten a plumber's pipe connector over the end of the frame stop. A plumber's pipe connector is a 3" diameter rubber tube about 4" long and about 3/8" thick with a stainless steel hose clamp on each end. It is available at plumbing supply shops or stores such as Home Depot for about \$4.00 each. *Frank Howatt*
- Another method to cure overload spring slap is to cut and fit a piece of old tire carcass to the overload spring end, using one clamp to attach it at the axle end only. The cost is less than a dollar per side. *John Holmes/TDR writer*

7 COOLING

- To protect the cooling system from bugs and debris, insert an old aluminum-framed window screen behind the grille and ahead of the radiator, or simply cover the radiator with nylon window screen material. Then a few taps of the hand will remove the collected bugs. This quick fix provides a free or almost free preventive maintenance solution.
- For extreme cold weather operation if you install a winter-front radiator cover on your truck, it must have a minimum one square foot opening in its center for radiator and intercooler airflow. This tip is from the Cummins, 5.9 Liter Engine Operation's Manual. Issue 66, page 8, has an excellent article on winter-fronts.
- The correct type of antifreeze/coolant to use in your Turbo Diesel is an ethylene glycol (not propylene) based product. If possible, use a low silicate, diesel-type of coolant. It should be mixed fifty-fifty with distilled water. Or you can buy a pre-mixed product. But if you "mix your own," be sure to mix thoroughly before pouring it into the cooling system. TDR Issue 62, page2 42-44, has a complete technical article on antifreeze.
- Installing a piece of metal screening in front of the truck's radiator is strongly recommended. With three radiators (engine cooling, air-to-air intercooler, air conditioning condenser) it is important to have maximum airflow and minimum clogging due to bugs, chaff and dirt. The screen should also stop radiator penetration by rocks.
- To fix a cut radiator hose I cut the ends off a Dr. Pepper can, then split one side. I slid it over the hose and wrapped it in nearly a whole roll of electrical tape. I finally got around to changing the makeshift hose six months later. *BDW*

8 ELECTRICAL

- On '89-93 trucks, the voltage regulator seemed to fail too often. Member Earl Peck solved the problem by relocating the regulator to the front of the hood pivot assembly on the left side of the engine, away from all the engine's heat. His regulator hasn't failed since. On Second Generation and newer trucks, Dodge redesigned the system, and the regulator is integral with the alternator and it is not a problem. *Earl Peck*
- On some maintenance free batteries it is possible to check the electrolyte level. If the case is transparent or white plastic, shine a flashlight on the case while looking at the other side of the case. The liquid level will clearly show. Try this in a garage or other low-level light situation. *David Burton*

- If your truck's batteries discharge while the truck isn't used for a few days, check to ensure the underhood light and the glove compartment light actually turn off when the hood or glove compartment door is closed. The switches of these two lights can fail, leaving the light on all the time, thus draining the batteries. *Jim Anderson/TDR Writer*
- When battery replacement time comes, always replace both batteries as a matched pair of equal or greater capacity than the original equipment batteries. Replacing only one battery of a two battery system is false economy as the greater internal electrical resistance of the older battery ensures the newer battery will be overcharged and its life greatly shortened. *Jim Anderson/TDR Writer*
- The most frequent leak in the plumbing system from the turbocharger to intercooler to air intake occurs at the bottom of the boot connection at the turbo. Next comes connections on the "hot side" of the charge-air system. Leaks on the "cold side" (after the intercooler) are much less frequent. Also, check your mirror for excessive black smoke on acceleration as an indicator of a boost leak. *John Holmes/TDR Writer*

9 ENGINE

- If you need to turn the engine over to locate Top Dead Center of a cylinder and lack the special tool to do this job, use a 22 mm socket wrench on the alternator pulley nut. Turn the engine backwards from its normal rotation (backward rotation for servicing is not a concern) to keep the pulley from slipping on the belt. Or put a socket on one of the crankshaft damper nuts and have an assistant turn the engine over from underneath the truck.
- An easy and clean way to drain the engine oil is to loosen, but not remove, the drain plug. Oil will come out of the pan through grooves cut in pan sides if the plug is loosened by more than two turns. Then you don't have to fish in the drain pan for the plug and gasket. *Louis Barnhart*
- Oil changes become even simpler and cleaner with the addition of an inexpensive accessory called the EZ change drain plug, which replaces the standard drain plug. By screwing on a special hose/adaptor at drain time, the plug's drain valve automatically opens, and the draining oil is directed through a hose to the drain pan. Removing the drain tube reseals the plug. The Fumoto drain plug is another way to solve this messy problem. These plug kits are available from Geno's Garage, www.genogarage.com.
- A way to loosen a tight oil filter or canister-type fuel filter is to take a long flat-blade screwdriver, place it on the filter rim at the proper angle and strike it several times with a hammer to drive the filter in a counter-clockwise direction. *Louis Sytsma*

- It is easier to pour new oil into your engine if you make your wobble-proof funnel from a used plastic 1.75 liter Skol Vodka jug. It seems the spout diameter and lid threads are an exact fit to the oil fill opening and threads on your Cummins engine. *R.J. Stamper*
- Member Scott Morneau adds that you can use the oil fill cap to test other potential bottles. If the oil fill plug fits the cap of the bottle, the bottle will likely fit in the oil fill port.
- Here's a free pre-luber for your Cummins engine. If your engine is not run for long periods, or if you want to build oil pressure before starting it in cold weather, or after an oil change, disconnect the fuel shutoff solenoid wire and crank the engine for 15 seconds. Reconnect the wires and crank it again to start it. It's an "almost free" solution if you add a switch in the cab to make raising the hood unnecessary. Excerpted from the Cummins Operations Manual, the tip applies to all the 12-valve engines.

How about removal of the oil filter for the 6.7-liter engine? Is it harder to access than the 5.9 engine? My tip: I first loosen the oil filter with an oil filter wrench. After it is loose, I place a modified 1-liter bottle (the bottom is cut off) around the filter. As you would expect, I leave the cap on the bottle. As the filter loosens, it drops into the bottle and catches the oil. I hold it there for a moment, then remove it, after which I wipe the filter housing off. It catches most of the oil, leaving very little mess. I hope this may help some of our TDR members.



Looking up at the filter with the plastic bottle in place.



The grand prize: used oil filter and dirty oil fit nicely into the bottle.

Lawrence Varhaul

- Member Ed Wash of Alaska wrote in to ask for a solution to oil dripping from the plastic pipe road draft tube under his engine. It is normal for a drop or two to come from this tube when the truck has been parked overnight. A member solved the same problem by drilling a 1-1/4" hole in the lid of a large Roloids jar, and drilling eight holes around the top of the jar body. Drill a horizontal hole at the bottom of the draft tube. Slide the lid over the hose and secure the underside with a tie wrap. Screw the jar onto the lid. It catches the drips! Keeps the driveway spotless.
- If you have trouble reading the oil level dipstick without your glasses, put the dipstick in a vise and file a "V" notch in the side of the stick at the "full" mark and one at the "add" mark. This makes it much easier to read the oil level accurately. *Steve Richards*
- Here's the editor's all-time favorite low cost service tip! When removing the oil filter, use a large heavy-duty freezer bag. After loosening the filter part way, slide the zip-loc freezer bag under and around the filter, then spin the filter off and let it drop into the bag. Zip-up the bag. No mess, and it is then easy to remove the filter from its crowded location. I will note, however, if your engine is hot, you may need to work fast or the filter could melt through the bag. *Justin Kirchoff*
- Finally, another method is to drain the filter first by punching a small hole in its bottom before removing it. *Dave Lewis and James Johnson*
- When changing the serpentine accessory drive belt, always check the idler tensioner pulley to make sure its bearing is good. The belt change interval is every 100,000 miles.
- The turbocharger to intercooler to intake manifold piping clamps can come loose, causing loss of turbo boost. Check all rubber boots and clamps periodically for boot slippage under the clamps, particularly if a loss of performance or a whistling noise is noticed while the engine is under load.
- Periodically inspect the engine water pump bearing for leakage. If any coolant is seen to drip or "weep" from the pump shaft area, replace the pump before it fails.
- On 1998.5-2002 trucks, extend the crankcase vent tube rearward along the driver side of the engine using an extension hose whose inside diameter is equal to the outside diameter of the existing hose to get the vent tube exit out of the cooling fan's airstream. First remove the oil drip catch bottle from the end of the existing hose, clip and remove the wire tie and bottle screw cap and remove from the hose. Install the extension hose and use a wire tie to hold it to the existing hose. Run the hose extension down and rearward at least two feet along the engine oil pan, using one or more wire ties to hold the extension in place. The existing hose end allows the fan to pick up oil mist and deposit it on the rear side of the radiator where it will clog the radiator with oily dirt which can lead to engine overheating. *Jim Anderson/TDR Writer*
- On 2007.5 and later trucks with the 6.7 Liter engine, if you do a lot of slow or short trip driving, the diesel particulate filter will load up and set an engine trouble code if driving time at higher road and engine load speeds aren't sufficient for the particulate trap to go through a full regeneration cycle. If your driving includes short trips, slow speeds, and/or slow speed cold weather operation, drive your truck at least 20 miles at highway speeds (55+ mph) once per week to allow the system to complete a diesel particulate trap regeneration cycle. *Jim Anderson/TDR Writer*
- Often TDR members ask about the "best" air cleaner or about performance-type air cleaners for their trucks. So I posed the question to TDR technical writer Joe (I've spent some time on the dyno) Donnelly. Joe responds: I covered airflow and dynamometer-measured horsepower in TDR Issue 37, page 26. Under 500 horsepower, the stock airbox and filter were sufficient. I have used aFe ProGuard 7 and BD Power filter systems in high horsepower applications where higher airflow is needed. So, to address performance, there is essentially nothing to be gained by changing the air cleaner.
- If you want a more recent and thorough look at air cleaners, Issues 56 and 59 have a total of 12 pages that look, not only at dyno-tested horsepower, but also air intake temperature and air density.
- Finally, the folks at Dodge, Cummins and Cummins subsidiary company Fleetguard, did extensive testing on air cleaners way back in 1999. The purpose of the test was to push-back engine related problems to the source—too much unclean air. The result: premature piston ring-to-cylinder bore wear is not covered under the role of the factory warranty (Issue __, page __). *Joe Donnelly/TDR Writer*
- Editor's comments: I think the more you learn about air cleaners the more you'll be convinced that the factory set-up is the best all-around choice. After all, with a factory box there are no questions about cleanliness or warranty coverage. *Robert Patton/TDR Staff*
- "Killer dowel pin" and bolts inside the gear case: This issue has been discussed many times in the magazine, so we will just give the latest references: Issue 55, page 34; Issue 56, page 106; and Issue 58, page 125. Suffice it to say that any Turbo Diesel up through the 2002 model year is vulnerable, and the 12-valve engines are most prone to experience failure. *Joe Donnelly/TDR Writer*
- Exhaust manifold: The 12-valve manifold shrinks until it breaks mounting bolts or mounting "ears" on the head. The 24-valve manifold cracks and leaks hot exhaust gases to the hood surface, or the automatic transmission cooler. The early (2003-2005) HPCR manifold has poor flow from ports 4 and 5. An aftermarket replacement manifold is the proper fix for these engines. *Joe Donnelly/TDR Writer*

- Some non-Cummins/Fleetguard oil filters have been known to disintegrate and cause engine damage. Back in 2001 there was an information-only factory Technical Service Bulletin that discussed the problem (TSB 09-004-01 dated 5/18/01) Similarly, small pieces from the foil sealing disks for oil jugs have been known to get poured into the engine, causing failures. Piston cooling nozzles are particularly vulnerable to being plugged-up by foreign objects. *Joe Donnelly/TDR Writer*
- Serpentine belts and coolant hoses seem to last a long time in normal service. Obviously they are more “fun” to replace at your convenience, on a cold engine, than at the side of the road. Should you consider installing a new one? *Joe Donnelly/TDR Writer*
- In Issue 62 (on page 96) I discussed the lifespan of HPCR injectors. Bosch has changed from regular steel to stainless steel bodies recently, so the new injectors represent a nice upgrade for us. It seems that injector failures are occasional and sporadic up to 100,000 or 150,000 miles. After that mileage, failure is more likely. I decided to upgrade to the new stainless injector bodies and get Stage 1 nozzles from Dynamite Diesel Performance at about 100,000 miles. Many owners feel that they can go for longer periods of time on the original injectors. Again, from experience, I know that changing injectors on a hot engine at the side of the road is very undesirable. If you get towed to a shop, they may or may not be good at the procedures and may or may not be willing to get anything other than remanufactured replacement injectors from Bosch or Dodge. I definitely don't trust remanufactured HPCR injectors. The check ball seat erodes, especially with high rail pressures, and is a mode for failure. Overheating (very high EGT) is another mode for failure (cracked bodies). *Joe Donnelly/TDR Writer*
- The sealed bearings in the belt tensioner, idler pulley, and fan hub wear out. Parts may be difficult to find. At a minimum, check them periodically for wobble and roughness (when you remove the serpentine belt partially or completely). *Joe Donnelly/TDR Writer*
- TDR member Earl Kenney cautions us about diesel fuel storage. Fuel stored in cans can collect water that may produce gels. Fuel stored for long periods in cans coated with galvanizing or zinc will liberate a chemical from the coating that can form harmful compounds, resulting in hard crystalline deposits in the injector system.
- On '94 through '98 12-valve Cummins engines there is a fuel pre-filter/heater that most mechanics don't know about. It is located between the fuel tank and the fuel transfer pump, low on the engine left side near the rear. The bottom bowl screws off, and the plastic strainer screen should be cleaned periodically. Don't forget to properly reseal the gasket before reinstalling the filter bowl. *Robert Patton*
- Trucks using an aftermarket remote-mounted fuel filter have experienced abrasion of one or both hoses where they have contacted engine parts, other underhood parts, or each other. Cover both lines with convoluted loom or rubber hose and route them in such a manner that they don't touch anything.
- When changing out a fuel filter cartridge on 1999-up trucks where the filter is removed from the top of the engine, use a one gallon plastic jug with the top cut off to put the fuel filter in immediately after pulling it from the canister. This eliminates fuel drips all over the top of the engine and front bumper. Leave the filter in the jug for a day to allow it to completely drain of fuel before putting it in the trash. The dirty fuel in the jug can be used as a good parts cleaning solvent/degreaser. *Jim Anderson/TDR writer*
- On all 12-valve engines with the P-7100 injection pump (all '94-'98.5 trucks), a fuel return line runs from the engine side of the injection pump (near the front of the pump) to return unused fuel to the fuel tank. Part of the line is rubber. This rubber line, hidden under the intake manifold, is subject to heat deterioration and should be replaced approximately every 50,000 miles. (This problem has been well documented in the TDR.)

14 FUEL

- In model years '94 through '98 the engines are equipped with a plunger-type fuel transfer pump with a button-type primer. It is hard to locate and see the plunger button to prime the fuel system. Paint the end of the plunger with a bit of white paint for greater visibility. *Jim Anderson*
- With the introduction of the Second Generation trucks in '94, many members adapted to the decreased clearance problems in removing and replacing the fuel filter by using a filter strap wrench with a socket extension to remove the old fuel filter. The procedure is to disconnect the water sensor wire, thread the strap wrench under the wire and the drain tube onto the filter near the top, tighten the wrench strapping and loosen the filter. It is then spun off and removed by hand.

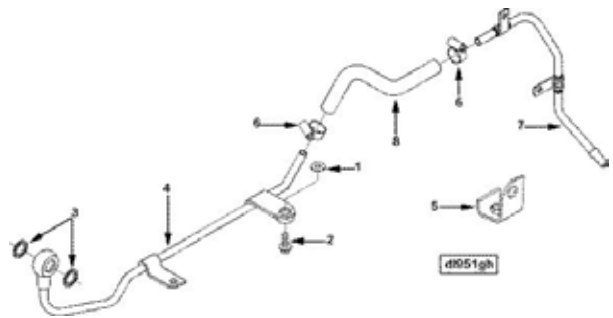

Look closely for the problematic fuel return line.

- All rubber fuel lines, both supply and return, should be checked periodically for integrity. Some lines can leak fuel, or admit air to the system, or cause loss of prime and resultant hard starting.
- The fuel filter drain hose is too short to be useful. Make and install an extension hose of the same diameter as the original that is long enough to hang below your truck's front suspension. Slide a pan or jug under the extended hose to catch the fuel as you drain the filter canister for a filter change. *Jim Anderson/TDR writer*
- I had an abrasion cause a leak in a rubber fuel line. I used a 2" length of a Sharpie marker with the ends cut off to reconnect the fuel lines. The internal passage of a Bic pen works well for a smaller diameter hose. *RLHannink*
- Lift (fuel transfer) pumps do fail. The mechanical pump on 12-valve engines rarely fails completely. It generally leaks externally or delivers less pressure as the plunger bore gets scored from debris or grit. The 24-valve electric lift pump has been less reliable, as has the HPCR electrically driven pump mounted on the side of the fuel filter canister on 2003-2004 engines. The 2005-up pump inside the fuel tank seems more reliable. All of the electric pumps deliver less fuel than needed for big power upgrades and are unpleasant to access, especially with a hot engine (or full fuel tank). A replacement pump such as the FASS makes inspection and replacement easier, and many of the aftermarket units are longer lived as well as higher capacity. If you travel to remote areas, you probably should carry a spare lift pump that you can install relatively easily, along with tools. You definitely should have a fuel pressure gauge for any Turbo Diesel equipped with an electric lift pump. *Joe Donnelly/TDR writer*

18 VEHICLE PERFORMANCE

- Interested in improving the highway fuel mileage of your Dodge? Joe Kubina, Aerodynamic Development Engineer at Chrysler Corp. says removing or laying down the tailgate on your truck *will not* improve fuel mileage, and in fact, could worsen it. It seems the Dodge body shape is designed to flow air properly across a closed tailgate to maximize highway fuel economy.
- All 4x4 trucks built after 1994 use engine vacuum to engage the front axle drive. Periodically inspect the vacuum hoses going to the front axle for holes, abrasions, and splits. A damaged vacuum hose will prevent the front axle from engaging when the 4x4 lever is shifted in the cab.

19 STEERING

- A steering "clunk" in two wheel drive trucks produced after 1993 can be traced to lube pushing out of the telescoping steering column parts into the rubber boot on the shaft. Squeezing the boot to push lube back into the splined area is a temporary cure for the "clunk." A replacement steering shaft/coupler is a long-term solution.

In 4x4 models, a "clunk" similar to that found in two-wheel drive trucks may be caused by faulty track-bar bushings or worn front suspension grease joints.

- "Groaning" and other front suspension noises on 4x4 models built prior to 1994 can sometimes be traced to the universal joints at the outboard axle ends of 4x4 models. A simple test is to engage the manual locking hubs and drive the vehicle. If the noise disappears, replace one or both joints.
- On 4x4 models, a front-end shimmy may be caused by a worn steering stabilizer unit. This horizontally mounted shock absorber should be periodically replaced as a wear-out item. This problem appears more frequently on trucks equipped with aftermarket tires and rims of a larger than standard size.
- During servicing, don't forget to check the fluid level in the power steering pump. It is located low on the driver's side of the engine near the front in a location covered by hoses and wires.

21 TRANSMISSIONS

- Michigan TDR member Paul Refer wrote in to say his automatic transmission would not go into overdrive after a cold start in very cold weather. The editor pointed to the Owner's Manual that says, "If the vehicle is started in ambient temperatures of -5 degrees F or below, the overdrive will not turn on. This protects the transmission from damage if the cooling system freezes. Overdrive operation will resume when the ambient temperature has risen to approximately +2 degrees F."
- If you tow or haul heavy loads with an automatic transmission, a transmission temperature gauge is a must. Reluctant to cut a hole in the oil pan to install the sensor? Member John Holmes tested a gauge/sender made by Westach in which the sender is installed on the transmission oil dipstick. Slick—and it works! Available as a kit from Geno's Garage, www.genosgarage.com.
- When installing a new automatic transmission pan gasket, or almost any other gasket that doesn't want to stay in place during the mating of the gasketed parts, spread a light coat of chassis grease on one surface and place the gasket on it. The gasket will then stay in place and be lined up for the rest of the installation. *Robert Patton*
- When checking the oil level in your automatic transmission, it is important to follow the Owner's Manual directions that specify checking the level with the transmission in neutral, not in park.
- Does the transfer case shift lever in your 4x4 truck buzz and vibrate? Remove the trim and cement a small piece of rubber inner tube to the shift gate in the 2H position. Alternatively, you can place a wire tie on the lever where it passes through the shift gate. *W.L. Mayo and Robert Patton*

- In a standard oil change of the automatic transmission, only about five quarts of the old fluid can be drained out. To get a complete change (for example when switching to synthetic fluid), disconnect the transmission cooler line at the radiator, cut and fit a piece of hose to the coupler end and place the other end in a five gallon container. Put your truck in NEUTRAL with the brake on, and start the engine. ATF will flow into the container. As soon as the flow begins to dwindle, immediately shut off the engine. Reattach the cooler line, and refill the transmission with fresh ATF before restarting the engine. It may take up to 11 quarts. Issue 64, pages 11-12, has all of the details. *Scott Dalgleish/TDR writer*
- The cooling lines for automatic transmissions can have a point of close contact with each other where they cross near the bellhousing. A piece of convoluted loom or rubber hose placed on one of the lines will prevent chafing and wearing through of the metal tubing.
- Draining and refilling the automatic transmission oil pan is not fun for the backyard mechanic because the pan cannot be drained before removal. B&M offers a drain plug that can be inexpensively installed in the pan to make fluid and filter changes easier and cleaner. The plug is available from Geno's Garage, www.genosgarage.com.
- In '94 to '98 trucks with automatic transmissions, cooling lines have plastic quick-disconnect couplers that can fail under high heat conditions, causing a loss of transmission fluid. A revised coupler is available from Dodge parts. Or you can make your own, using weatherhead brass fittings of the appropriate size, available at most auto parts stores. The fittings are listed under the trade name Dana/Weatherhead 68x8x4. Caution: we have seen reports that the "hard" fittings can cause stress cracks in the transmission line due to vibration.
- When draining the lube from five-speed manual transmissions, remove the PTO cover from the side of the transmission. Start with the bottom bolt, since it acts as a drain plug.
- The most frequent complaint we got in the shop was, "It's shifting up and down out of OD." Of course it wasn't shifting, it was the locking and unlocking the TC clutch, which caused the tach to jump. The fixes to this problem are in order of most frequent to least frequent solutions: clean the battery terminals (solves about 50%); replace batteries due to a bad cell (engine still cranks); TPS - dirty, water, misadjusted; and the alternator. *John Holmes/TDR Writer*
- When changing a tire on your truck, use a crowbar with the tip placed under the jacked up tire as a lever assist to get the wheel and tire on or off of the lug studs. Place a piece of wood under the crowbar one foot away from the tire to use as a lever fulcrum and use your hand on the other end of the crowbar to press down, thus slightly lifting the tire on the studs. The curved crowbar end will keep your knuckles from hitting the ground if the crowbar slips. *Jim Anderson/TDR Writer*

23 BODY

- If your shoulder/seat belt buckle rattles against the interior trim while driving, install a small piece of velcro on the back of the seat belt buckle/ trim where the buckle hits the trim. With the velcro the buckle will stay in place. *Robert Patton/TDR Staff*
- To remove bugs from the grille area, fill a spray bottle with one part diesel fuel, one part water, and a small amount of detergent. Shake well and apply, let it sit, then hose it off. *Tom Clayton*
- Four-wheel drive, 2500 series Dodge trucks come with plastic rear wheel well liners as standard, while two-wheel drive trucks do not. The four-wheel drive liners can be used on two-wheel drive trucks with no modifications. They are available through Dodge parts for about \$85 per set. The liners make cleaning easier and prevent mud and salt buildup in the fenderwells.
- Do your outside rearview mirrors jiggle when going down the road? For trucks equipped with an aftermarket wind deflector/bugshield, start your troubleshooting by removing it. The same advice applies if your radio antenna whips about violently.
- If your pickup has a top over the bed, wedge a section of foam pipe insulation across the bottom of the bed where the tailgate closes against the bed. This will keep most dust and water out of the bed interior.
- Gauge fit: When installing aftermarket gauges into their respective gauge pod or circular hole, you can fit the gauge-to-hole by using black electrical tape wrapped around the gauge to give you just the right amount of interference. Alternately, if the interference is too tight, use sandpaper or a Dremel tool to remove some of the plastic in the gauge pod or hole. *Tip by Geno's Garage, www.genosgarage.com*
- Change the badge: add a personal touch to the interior or exterior of your truck with the addition of a well placed "DODGE" or "RAM" emblem.

22 WHEELS and TIRES

- This is a reminder that different tire pressures are used for loaded and unloaded truck operation for longest wear and best ride. Go by the sticker on the driver side doorjam. Always inflate the spare tire to maximum pressure as listed on the tire's sidewall. *Jim Anderson/TDR Writer*

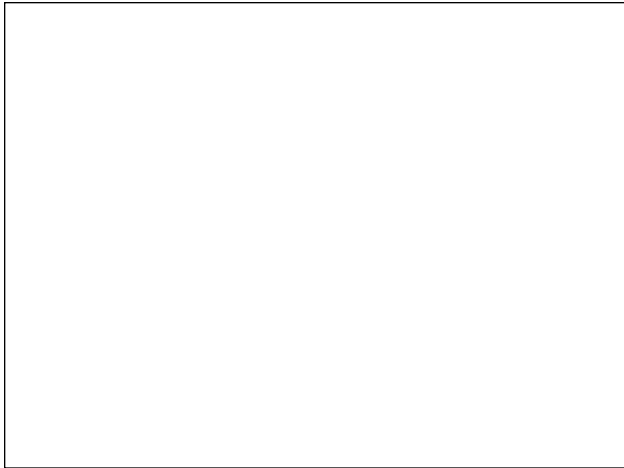

- Add some decals: You've got to love this "Super B" decal from the folks at Genos Garage, www.genosgarage.com. Notice the six-cylinder engine and turbocharger, details that tell the observer that this is a Cummins B.

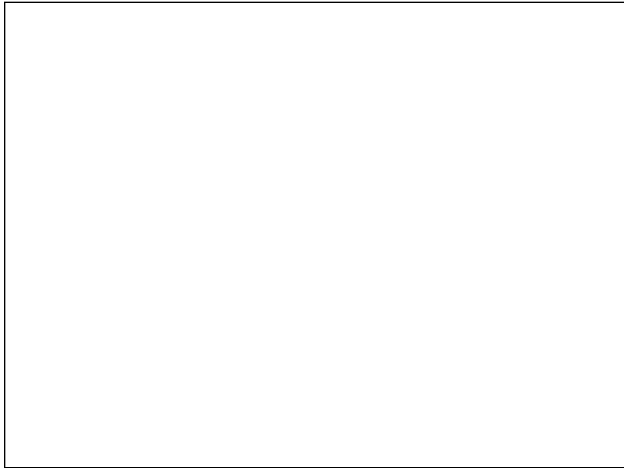

- Texturized paint:

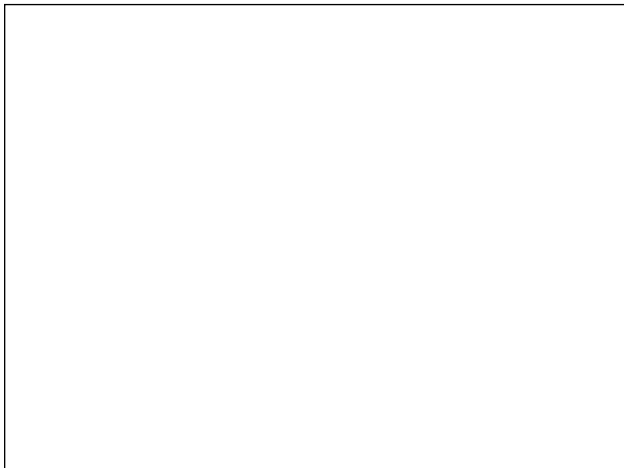

- Texturized paint/ditch the chrome:

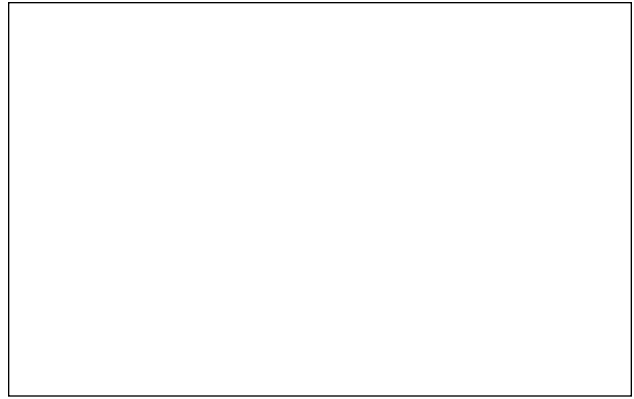

- To organize storage under the rear seat of Extended Cab, and four door cab truck models, use plastic coffee or other such containers to organize storage items. Place soft or flexible items in the space voids between and around containers. This lessens rattles while maximizing storage capacity. *Jim Anderson/TDR Writer*
- A hunk of cedar wood under the seat also provides a nice scent. *Polly Holmes/TDR Writer*
- If you park your truck for any length of time without using it and there are pack rats in your area, the damage they can do to the electrical system can be extensive and costly. To avoid this go to a janitorial supply and buy a box of toilet bowl deodorizer cakes. You know, those crystalline pink blocks that give public washrooms their super-sanitary aroma. Unwrap one and place it somewhere on the frame underneath the truck, secure it in the toe of an old sock or pair of panty hose and hang it in near proximity to your Turbo Diesel. Replace the cake when necessary. This tip also works for RVs or other parked vehicles were wiring rats love to gnaw. *Jeannette Vallier*

24 AIR CONDITIONING

- If you notice an objectionable odor coming from the dash vents of the heat/air conditioning system, spray some Lysol or other disinfectant spray into the vents while the system is shut off. This will usually eliminate any mold growing in the air delivery system. *Jim Anderson/TDR Writer*

26 MISCELLANEOUS

- Here are several cleaning tips: After washing your truck, give it a final rinse using water from the hose without the nozzle on it. The solid stream results in fewer water beads on the waxed surface. Clean window glass with a mixture of ammonia and warm water applied with a cloth or sponge. Dry the glass with old newspaper pages. Cheap and effective! To clean your engine, use a solution of Simple Green in water. Spray it on a cold engine, let it sit briefly, then hose it off. *Contributed by Don Mallinson and Robert Patton/TDR Staff*

- Installing a pyrometer gauge in the exhaust provides the greatest accuracy in assessing exhaust temperature. Pyrometer temperature should read less than 350 degrees before shutting down when measured in the exhaust manifold prior to the turbocharger. Gauges are available from Geno's Garage, www.genosgarage.com.
- On '99 and newer trucks with central locking, the doors automatically lock at speeds above 15mph. Your owner's manual explains how to disable this feature if you desire.
- Trailer tip: When putting a car on an open trailer do you have to spend time aligning the trailer ramps? Okay, you don't but those that are there to help(?) you are often clueless. Take away the guesswork with some spray paint.



- Trailer tip: We have all had to change a flat trailer tire. After one less-than-ideal situation I learned my lesson. The Trailer-Aid that is sold at Geno's Garage (\$49 at www.genosgarage.com) allows you to change a trailer flat without having to jack up the trailer. Drive the good wheel/tire onto the Trailer-Aid and the height of the axle is sufficient to change the bad wheel/tire. If you like the idea, a spend-thrift version can be made using incremental lengths of 2" x 6" lumber.
- If you tow a fifth-wheel or gooseneck trailer, carry a three foot stepladder in the truck bed. The ladder enables you to get over the side into the truck bed or to gain access to a bed mounted toolbox or auxiliary fuel tank while the trailer is hooked up.

Jim Anderson/TDR Writer

- How to change a trailer tire on the side of the road:
 - Remove from trailer
 - Use trailer landing gear to break bead
 - Use large screwdriver, breaker bar, soapy water and hammer to remove bad tire from rim
 - Use same screwdriver, breaker bar and soapy water to pry new tire onto rim
 - Place ratchet strap around tire (to balloon it out) and air it up
 - Remount on trailer and drive home

ewcmr2

MECHANICS TIPS

Here's a collection of tips to help the mechanic/handyman while working on his or her vehicle. These tips have been collected by the editor over a period of years from many different magazines and other sources, and have been organized into categories for easier reference.

WORK ENVIRONMENT

First, here are some tips from the pros about your work environment.

- Never wear rings or other jewelry while working on your vehicle. Jewelry can scratch paint, get caught in turning belts, cause wiring short circuits, and otherwise ruin your day!
- Keep your work area and tools clean, neat and organized. That way things will be easier to find when needed, and safer to use.
- Wipe up floor spills before you slip and fall. Keep tools free of grease and oil so your hands won't slip off.
- Place removed parts in a safe place so you won't trip over them while moving around the vehicle.
- Provide proper light for a better quality repair.
- Provide adequate ventilation if you are using chemicals or fuel as a solvent.
- Adequately support the vehicle on jack stands if you are working underneath it. Use jacks and chains to support or move heavy loads.
- Never put a tool back in the toolbox without first cleaning it to be ready for the next use.

VEHICLE TRIM

If your pickup has a top over the bed, wedge a section of foam pipe insulation across the bottom of the bed where the tailgate closes against the bed. This will keep most dust and water out of the bed interior.

If you install carpet remnants in your cab or truck bed, you'll soon find that the cut edges will fray. To keep the edges looking neat, lay the carpet on a concrete floor, lay a piece of metal 1/8 inch from the edge, then heat the carpet edge with a propane torch. Use care not to get the carpet too hot as you simply want to melt the synthetic fibers enough to seal the edge from unraveling. This tip will not work on carpet with all-natural fibers. Practice on a scrap piece first.

*Wrap a fingertip with duct tape,
glue side out...*

TAKE IT OFF

When you disassemble any piece of mechanical equipment, you will end up with a bunch of random fasteners and pieces, and can easily forget your re-assembly order, or you can lose one or more fasteners. Use several small plastic tubs to hold stuff, and/or a large plastic tray where parts and fasteners can be laid out in the order they were removed. Just turn the tray around for re-assembly in order. If you leave your worksite, cover the tray or tubs with plastic food wrap to keep things from being disturbed. For long-term disassembly a freezer bag marked with the content description is a good alternative.

STUBBORN FASTENERS

If your screwdriver slips off a Phillips or slot head screw when you try to loosen it, put a bit of grinding compound in the slots to increase the screwdriver's grip on the fastener.

Another method is to strike the end of the screwdriver with a hammer while twisting it to break the fastener loose. This works particularly well on aluminum fasteners, or with steel fasteners in aluminum. Better yet, purchase an impact screwdriver to properly loosen those stubborn fasteners.

If you are trying to install a screw in an inaccessible place, tape the screw to the screwdriver point, insert the screw in its hole and turn it in. The tape will eventually fall off. A dab of grease or body putty may hold a light screw the same way.

Want to prevent a fastener from rusting after it has been installed? Simply coat the head with clear nail polish.

Clear nail polish also works as a thread locker. Coat the threads, then quickly install the fastener.

For removing rusty nuts and bolts, always use penetrating oil first, and let it soak a bit before trying to break them loose.

If you're trying to fish a part or fastener out of an inaccessible place, simply wrap some duct tape sticky side out around the end of a straightened coat hanger. It may take a couple of tries, but if the tape will stick to the part, the part will come out with the coat hanger. This works better than a magnet if you are working in an area full of metal.

Ever tried to hold a nut in a tight spot while threading a bolt into it? Wrap a fingertip with duct tape, glue side out, or make a loop of the tape to stick it to your fingertip, then place the nut on the tape. The nut will stay put and not rock around while starting the bolt threads.

ELECTRIC TIPS

When taping a bundle of wires together, coat the tape end with clear nail polish to keep it from coming loose.

If a vehicle battery is constantly boiling over, check and clean the ground from the alternator and/or voltage regulator to the vehicle frame. A poor ground connection will cause the alternator to put out too much juice. Measuring alternator output with a voltmeter may show it is putting out 14.8 volts or more, when it should charge at 14.2 volts.

When the rubber boot covering your positive battery terminal connector becomes worn, replace it with an old spark plug wire boot, or make a sleeve-type cover from an appropriate size plastic bottle.

Just a reminder, when replacing quartz halogen lights, use clean cloth gloves or otherwise cover the bulb with clean cloth or paper to prevent oil from your hands getting on the glass. Finger oils make the glass shatter under high heat conditions.

LUBE TIPS

Trying to pour oil or other fluid into a fill hole and don't have a funnel handy? Stick a screwdriver in the fill hole and pour the liquid down the screwdriver shaft. It will follow the shaft into the fill hole.

Need some good parts cleaning solution but hate to spend the bucks. Use old automatic transmission fluid. It will make greasy parts shiny- clean after an overnight soaking. Wash the ATF off with soapy water.

If you have a mysterious oil leak on your automatic transmission, check where the transmission dipstick tube goes into the case. You'll likely find a cracked "O" ring when you remove the dipstick tube. Replace the "O" ring for a quick fix.

FILTER TIPS

If your engine oil filter or fuel filter simply refuses to budge when you're trying to remove it, let the engine fully cool off, and it may be much easier to remove.

To make the job of removing your oil filter easier and neater, put on a pair of surgical gloves. They improve your grip and keep your hands clean. When the filter is off the vehicle, simply hold the filter top with one hand, and with the other pull the glove off your hand by turning it inside out over the top of the filter. Then oil can't get out of the filter opening!

A commonsense reminder: before installing a new oil or fuel filter, write the date and mileage on the filter with a marker to make remembering these vital details easier.

Also, before installing a new oil filter or a new diesel fuel filter, prime it with the appropriate fluid first. Get the filter as full as possible.

Have you found yourself with a difficult-to-remove oil filter? You tried, with no avail, the band wrench, strap wrench, and filter claw tool that you found at the auto parts store. You tried the screwdriver through the side of the filter trick – only to have the screwdriver twist in place? Your last resort... try a hammer and chisel to the top edge of the filter housing. Oh yeah, be sure to knock the chisel in the counter-clock wise direction as viewed from the bottom of the filter.

Best ever filter removal tip: once the filter is moved from its tool-tight position to a hand-tight removal, place a large freezer bag around the filter. Now, when it drops from the housing, extra fluid simply spills into the bag and not on the floor. Additionally, it is easy to retrieve the bag-filter from around the air-conditioning lines, as you don't have to worry about tipping/spilling oil.

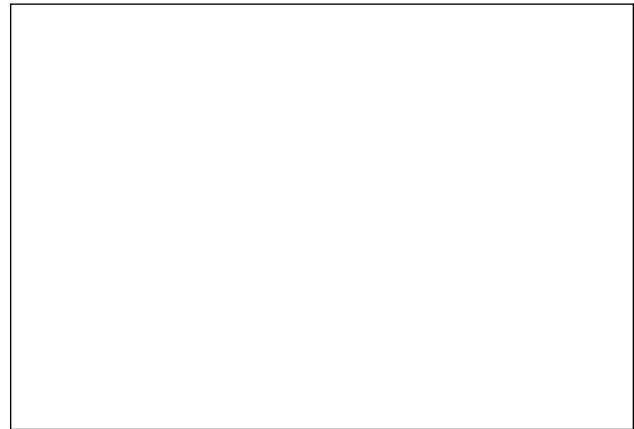

EMERGENCY REPAIRS

Emergency repair of small holes in a gas tank can be made by rubbing a bar of soap across the hole. The leak will stop. A permanent repair can be made using epoxy.

Emergency temporary repair of small radiator leaks can be made by putting in two or three egg whites. Start the engine to circulate the coolant and get the egg to the hole. Oatmeal or flour may also work.

An emergency repair for a hole punched in your oil pan is to round the hole with a punch, then insert a rubber tire valve, stem first into the hole. Coat the valve with gasket cement if available. Push or pound it home with a hammer.

IN THE TOOLBOX

Plastic tie-wraps are so handy, almost everyone has them in the toolbox. Keep them organized by hanging a bunch on a single tie, then cut the head off the single tie. Friction will keep them in place. To get a new one, just slide it off the end. When cutting off old ties, cut them near the back of the head so they can be used again for a smaller project.

Most tool kits contain both metric and standard wrenches. Color code with paint or tape the wrenches of a certain type to make them easier to identify.

If your ratcheting socket wrench handle constantly bangs on nearby metal while in use, slip a piece of rubber tubing over the handle end to cushion it.

If you want to magnetize a screwdriver or other tool, stroke its tip with a magnet. If you want to demagnetize a tool, run the shaft or tip between the electrode arms of a soldering gun while it is turned on.

Slip a tube of closed-cell foam pipe insulation over your floor jack handle to keep it from damaging the paint on the body sides of your ride. Leave the top of the handle clear for a good grip.

Make an old dental pick a part of your toolbox. It has many uses, such as picking up small parts, scraping gasket material out of tight corners, cleaning grease out of cracks, and aiding in assembly of small parts.

Cleaning up your tools after a project is fast and easy with this tip! Spray them with carb cleaner, and then wipe them dry and clean before putting them away.

THRU THE LOOKING GLASS

If your wiper blades streak the windshield or otherwise act as if they are worn out, don't replace them. Just sand them! That's right, run a block with wet 600 grit paper along the rubber wiper edge for a few strokes to remove the small cut places in the blades, and they'll work like new.

If your windshield is badly streaked from worn out blades, polish out the streaks with toothpaste. Apply to a damp cloth and wipe back and forth across the affected area applying moderate pressure. Rinse off the residue when finished.

CLEAN YOUR RIDE

An easy-to-make bug scrubber that won't scratch paint can be made by wadding several pairs of old panty hose together and using it as a wet sponge. This also works to remove tar from chrome trim.

Tired of getting spray tire dressing all over your newly cleaned wheels? Make a cardboard template to hold over the rims and spray away!

It is likely you already have a great tar remover in your toolbox. Spray WD-40 on the tar, let it sit, then wipe the tar off. It won't hurt the paint, either!

If you want the interior of your ride to always smell fresh and clean, lay a bar of Irish Spring soap under the seat. If you want a different scent, a sheet of fabric softener works too.

Your truck is washed and it is time to dry it. Before you break out the towels/chamois, let's play a little bit longer and put the water to work drying the vehicle. Say what... Follow the procedure. Remove the spray nozzle from the hose. Starting at the roof, let the steady stream of water collect the drops and flow them off the surface. Move to the windshield, hood, windows, doors, cargo box, tailgate. The

stream of water does a great job of drying your truck. Finish off the job with your towel.

CLEAN YOURSELF

A good way to clean your hands after a dirty job is to use soap and used coffee grounds. Just put some of each in your hand, add water, and then scrub 'till your hands are clean.

BODY WORK

When sanding inside curves, wrap sandpaper around an old piece of radiator hose or other thick walled hose of the correct diameter. You'll get a smooth material removal.

Planning to put a wild paint scheme or set of stripes on your truck, but you're not sure how it will look? Take some pictures of the truck, have them blown up to 8x10s, then use water-based colored markers to draw the different schemes on the pictures.

The indented bottom of a soft drink can makes a good place to mix up a small batch of two-part epoxy. The handle of a small plastic spoon or fork makes a good stirring stick and an applicator.

Old gaskets can be tough to remove from parts, even with a scraper. Chuck a wire wheel into your electric drill and brush them off clean. Be sure to wear safety glasses.

TAPE TRICKS

An easy way to keep grease from your hands and other dirt off new brake shoes during installation is to cover the shoe surface with masking tape. Remove the tape before you re-install the brake drums.

Masking tape or duct tape wrapped around the ends of the "U" joints on a driveshaft keeps the bearing caps in place while handling the shaft.

GET THE RIGHT SIZE THE FIRST TRIP

Determining the outer diameter of a piece of tubing or a bolt is easy. Just slip the appropriate size open-end wrench over the tubing, then read the size of the wrench.

MECHANICAL

When installing a gasket that refuses to stay in place during installation, put a light coat of chassis grease on the gasket's undersurface, then stick the gasket to the metal. It will now stay in place during assembly.

*Put a light coat of chassis grease
on the gasket's undersurface,
then stick the gasket to the metal.*

NEW OWNER'S CORNER...

Lube and service basics for your new truck. Always follow the recommendations in your Owner's Manual. Below are excerpts from the manual and further TDR commentary.

Breaking in your new truck: Drive moderately for the first 1,000 miles to assist in breaking in the powertrain, brakes, bearings, etc. Do not use full throttle for extended periods, and vary speeds frequently. After the first 1,000 miles, use the truck normally. Particularly during the breaking-in period, avoid extended idling. Your Cummins engine will break in faster if you haul or tow with the truck. The engine will not be fully broken in, and will not reach its full power and fuel mileage potential, until it has operated for approximately 10,000 miles.

Fuel: Use only #2 diesel fuel. As an option in winter you may use #2 diesel fuel blended with #1 diesel or kerosene, or #2 diesel otherwise treated to lower the pour point of the fuel. Use #1 diesel fuel for extreme cold weather operation only. Always fill at popular locations that sell a lot of fuel. Diesel that has not been subject to long storage should contain less moisture and sediment.

Engine Oil: Use any high quality lube oil diesel rated 15W-40 with the API "donut" symbol CJ-4 or better, such as Cummins Premium Blue, Shell Rotella T, Chevron Delo 400. For very cold weather operation, you may use a diesel rated 10W-30, meeting the same API spec as above. Do not use synthetic oil if your engine has less than 10,000 miles on it.

Change Intervals: Change your engine oil and oil filter according to the chart in your Owner's Manual. Change the fuel filter at every other oil change. Neither Dodge nor Cummins recommends using extended drain intervals with the use of synthetic engine oils. Change transmission and axle fluids according to the types of service listed in your Owner's Manual.

Anti freeze/Coolant: Drain and refill every 24 to 36 months, using low silicate, diesel-rated, ethylene glycol based coolant. Pre mix half-and-half with distilled water before installation or addition.

Automatic Transmission fluid: Change fluid and filter every 40,000 miles for normal operation. For operation such as towing or heavy loads, change every 15-20 thousand miles.

The latest Mopar specification is ATF +4, type 7176.

The latest ATF +4 can safely be used in all previous 47 RE/RH automatic transmissions. In this case, logic prevails – if +3 is good then +4 is better! This information was verified by D/C's customer advocate personnel. If you have any doubts about the correct transmission fluid, consult your Owner's Manual.

Five-Speed NV4500 Manual Transmission (used from '94-'04): Change every 30-50 thousand miles, depending on load. Use 75W-90, GL-4 or 80W-90, GL-4 rated synthetic oil. Often members will ask about the GL-4 rated Castrol synthetic gear lubricant (75W-90). If the GL-4 classification is good, shouldn't a GL-5 rated lubricant be better? In the case of the NV4500 gearbox, not necessarily so. The GL-5 oil uses twice the amount of sulfur/phosphorous additive package as GL-4. At high temperatures, the phosphorous plates out and reduces the coefficient of friction of the synchronizer rings (New Venture Gear has seen this on shift stand tests). Since there's twice as much of it, there's more of a detrimental effect compared to GL-4.

Although it does not affect the NV4500, the additional sulphur content of GL-5 attacks brass.

Six-Speed NV5600 Manual Transmission (used from '00-'05): This transmission is filled with manual transmission fluid at the factory. This fluid does not require periodic changing. If it is necessary to add or change the fluid in this transmission use Mopar manual transmission fluid (Mopar P/N 4874464 or Texaco 1874). These are the only lubricants recommended for use in the NV-5600 transmission.

Six-Speed/G56 and G56R Manual Transmission (used from '05-Current): The lube oil recommended for the G56 and G56R transmission is Mopar ATF +4 is readily available at your local auto parts store or Mopar dealership.

Axle oil: Change every 30-50 thousand miles, depending on load. Use 75W-90, GL-5 rated synthetic oil for normal light to medium load duty cycle.

Tires: Weekly, check for proper air pressure with tires at ambient temperature. Please follow the Owner's Manual recommendations for increasing pressure as load increases. Front: 45-55 lbs. Rear: 40-80 lbs.

Cold Starting: Turn on key, and when "wait to start" light goes out, start the engine. You may need to apply light throttle (up to 1,000 RPM) to keep the engine running if it is very cold. Allow two or three minutes of idling time for oil to circulate in the engine before driving away. Use light throttle until engine has fully warmed up.

Washing and waxing: New paint is soft for the first 30 to 60 days after spraying, and should cure up to three months before gaining full strength. Wash your new truck with clean water on a cool paint surface for the first 30 days. Use a soft cloth with a "nap" surface. If the truck is very dirty, use a mild car wash soap diluted in water and applied with a soft cloth. Do not wax your truck for 30 days, then use a cleaner-wax which is suitable for clear coated finishes.

MOPAR/CUMMINS/FLEETGUARD PART NUMBER REFERENCE

NOTES: This table includes part number supersessions as of 12/11. Part numbers at the top are Mopar; middle are Cummins; bottom are Fleetguard. For lube filters the numbers on the left are paper/cellulose media design. The numbers to the right are Microglass or StrataPore design. Belt part numbers are Gates. Hose part numbers are Gates or Mopar. Hoses are listed with upper hose (top) and lower hose (bottom) of chart.

MODEL YEAR	FUEL FILTER PART #	LUBE FILTER PART #	AIR FILTER PART #	BELT (Assumes A/C)	HOSES
2012	68065608AA 5257769 FS43255	5083285AA 3949561 LF3972 LF16035	53034051AB AF27684	K081264	55056954 AB U 55056955 L
2011	68065608AA 5257769 FS43255	5083285AA 3949561 LF3972 LF16035	53034051AB AF27684	K081264	55056954 AB U 55056955 L
2010	68065608AA 5257769 FS43255	5083285AA 3949561 LF3972 LF16035	53034051AB AF27684	K081264	55056954 AB U 55056955 L
2009	68061633AA 5257769 FS43257	5083285AA 3949561 LF3972 LF16035	53034051AB AF27684	K081264	52028872 U 55056945 L
2008	68061633AA 5257769 FS43257	5083285AA 3949561 LF3972 LF16035	53034051AB AF27684	K081264	52028872 U 55056945 L
2007.5 6.7-liter	68061633AA 5257769 FS43257	5083285AA 3949561 LF3972 LF16035	53034051AB AF27684	K081264	52028872 U 55056945 L
2007	05015581AB 3942470 FS19856	5083285AA 3949561 LF3972 LF16035	53032700AB AF26106	K081264	52028872 U 52028873 L
2006	05015581AB 3942470 FS19856	5083285AA 3949561 LF3972 LF16035	53032700AB AF26106	K081264	52028872 U 52028873 L
2005	05015581AB 3942470 FS19856	5083285AA 3949561 LF3972 LF16035	53032700AB AF26106	K081264	52028872 U 52028873 L
2004	05015581AB 3942470 FS19856	5083285AA 3949561 LF3972 LF16035	53032700AB AF26106	K081264	52028872 U 52028873 L
2003	05015581AB 3942470 FS19856	5083285AA 3949561 LF3972 LF16035	53032700AB AF26106	K081264	52028872 U 52028873 L
2002	05015581AA 3942470 FS19855	05016547AB 3937145 LF3972 LF16035	4728406 3097074 AF25541	K080810	52028715 U 52006482AB L

2001	05015581AA 3942470 FS19855	05016547AB 3937145 LF3972 LF16035	4728406 3097074 AF25541	K080810	52028715 U 52006482AB L
2000	05015581AA 3942470 FS19855	05016547AB 3937145 LF3972 LF16035	4728406 3097074 AF25541	K080810	52028715 U 52006482AB L
1999	04883963AB 3931476 FS19598	05016547AB 3937145 LF3972 LF16035	4728406 3097074 AF25541	K080810	52028715 U 52006482AB L
1998.5 24-valve engine	04883963AB 3931476 FS19598	05016547AB 3937145 LF3972 LF16035	4728406 3097074 AF25541	K080810	52028715 52006482AB
1998 12-valve engine	04883963AB 3931476 FS19598	05016547AA 3932217 3865405 LF3972 LF16035	4728406 3097074 AF25541	K080810	22081 U 22082 L
1997	04883963AB 3931476 FS19598	05016547AA 3932217 3865405 LF3972 LF16035	4728406 3097074 AF25541	K080810	22081 U 22082 L
1996	4741689 3923108 FS1253	05016547AA 3932217 3865405 LF3972 LF16035	4728406 3097074 AF25541	K080810	22081 U 22082 L
1995	4741689 3923108 FS1253	05016547AA 3932217 3865405 LF3972 LF16035	4728406 3097074 AF25541	K080810	22081 U 22082 L
1994	4741689 3923108 FS1253	05016547AA 3932217 3865405 LF3972 LF16035	4728406 3097074 AF25541	K080810	22081 U 22082 L
1993	4429107 3834656 FS1232	05016547AA 3932217 3865405 LF3972 LF16035	4713953 3097073 AF25023	080830	21930 U 20431 L
1992	4429107 3834656 FS1232	05016547AA 3932217 3865405 LF3972 LF16035	4428308 3097072 AF4555M	080830	21930 U 20431 L
1991.5	4429107 3834656 FS1232	05016547AA 3932217 3865405 LF3972 LF16035	4428308 3097072 AF4555M	080830	21930 U 20431 L
1991	4429107 3834656 FS1232	05016547AA 3932217 3865405 LF3972 LF16035	4428308 3097072 AF4555M	080816	20957 U 20431 L
1990	4429107 3834656 FS1232	05016547AA 3932217 3865405 LF3972 LF16035	4428308 3097072 AF4555M	080816	20957 U 20431 L
1989	4429107 3834656 FS1232	05016547AA 3932217 3865405 LF3972 LF16035	4428308 3097072 AF4555M	080816	20957 U 20431 L

WHY ASK WHY - LIQUIDS IN YOUR TRUCK

by Robin Patton

Servicing a new and unfamiliar vehicle model for the first time can be frustrating. As I thumbed through the Volkswagen New Beetle (diesel) Owner's Manual there were many listings for lubricants that only showed the manufacturer's part numbers (in this case, those of Volkswagen). Purchase of the Robert Bentley shop manual did not give any further insight. Nor did a visit to the local VW parts counter unlock the mystery of the specification of the lubricants needed for routine maintenance. Case in point, what is the specification for and, thus, alternate (read: less expensive?) the lubricant needed for the five-speed gearbox?

I took the path less researched, as there was not an easy answer, and purchased (\$20 per liter) the Volkswagen part number G005 000 oil for my gearbox. I vowed to get some answers to many of the other VW specific part numbers, as they have a special number for all things liquid [power steering (what is G002 000 synthetic oil?), oil, and antifreeze] used in the vehicle. The only thing easy was the DOT-4 brake fluid.

Thinking back, I had run into a similar situation with another foreign car I once owned. Anyone care to point me in the direction of a "Pentosin CHF 7.1 or equivalent" fluid for a car's power steering system? Perhaps your experience as a new Turbo Diesel owner and its unique liquids is not unlike mine with the Volkswagen's mystery lubricants. Care to explain the difference in the engine oil for a diesel versus the engine oil used in your car? How about the New Venture 4500, five-speed gearbox oil—what makes it so unusual? The NV5600 gearbox oil is yet again different? The G56 gearbox oil is different too? Friction modifier fluid for the differential—where do I find such a product? Automatic transmission fluid, specification ATF 7176+4, sounds strange to me. Anything special needed for antifreeze? Brake fluid? Power steering fluid?



Special lubricants for your vehicle.

Do my new car experiences parallel your experience with the new ownership of your Turbo Diesel truck? Can we take these frustrations and make them into an opportunity to learn? You bet. Let's start with the lubricant that gets changed with the greatest frequency, the engine's lube oil.

FIRST THING TO NOTE—YOUR OWNER'S MANUAL

Yep, time to issue the editorial disclaimer. The authoritative source for this article is the Owner's Manual from my '99 2500 and my '07.5 3500 Turbo Diesel. Specifications do change and you should use the products listed in your manual. Our article is an effort to clarify and thus help you find readily available lubricants. Also, our article is written to stress the importance of using the correct lubricant by giving you some of the technical reasons behind the lubricant's uniqueness.

LUBE OIL CONSIDERATIONS

Many of you inquire about selecting the "best" for your truck. We hear a lot of questions like, "How about Mobil 1 or the Castrol Syntec synthetic lubricants?" Good intentions, but these oils are not blended to meet the requirements of a diesel. The API (American Petroleum Institute) "donut" rating for both oils is CD. Note the first letter "C" stands for Commercial or compression engine (a diesel). The "D" is the specification test the oil was tested at and was able to pass. The "D" specification was developed in 1952.

Up until the '07.5 6.7-liter engines the diesel specification was CI-4 plus/SM.

For '07.5 and the new 6.7-liter engine it changed to CJ. Is the CJ specification better than CI+4? Good question. Up until the CJ introduction the lube oils were better as the specification evolved. The TDR Issue 54 thru 58 magazines had a lengthy discussion on why CJ may *not* be better than CI+4 for the pre '07.5 engines.

The oil also needs to pass the API S (S stands for a service or spark/gasoline engine) category and current specification M. The S classification is needed to address and prevent wear on the sliding camshaft tappets.

MANUAL TRANSMISSION

1994-2003 Five-Speed NV4500 Manual Transmission

Reference your Owner's Manual and you'll note instructions to change the NV4500's gearbox oil every 30-50 thousand miles, depending on load. Use 75W-90, GL-4 or 80W-90, GL-4 rated synthetic oil. Chrysler part number 4874459 or Castrol Syntorq. Often members will ask about the GL-4 rated Castrol synthetic gear lubricant (75W-90). If the GL-4 classification is good, shouldn't a GL-5 rated lubricant be better? In the case of the NV4500 gearbox, not necessarily so. The GL-5 oil uses twice the amount of sulfur/phosphorous additive package as GL-4. At high temperatures, the phosphorous plates out and reduces the coefficient of friction of the synchronizer rings, (New Venture Gear has seen this on shift stand tests). Since there's twice as much of it, there's more of a detrimental effect compared to GL-4.

Although it does not affect the NV4500, the additional sulfur content of GL-5 attacks brass.

Like the Volkswagen saga, the GL-4 rated, Castrol Syntorq lubricant is difficult, if not impossible, to find at the local auto parts store. Thankfully there are advertisers in the TDR [Standard Transmission and Gear comes to mind—they sell the Syntorq in 1/2 and one-gallon quantities, (800) 783-8726] that have this lubricant for resale.

2001-2005 Six-Speed NV5600 Manual Transmission

To quote from the Owner's Manual, "This transmission is filled with manual transmission fluid at the factory. This fluid does not require periodic changing. If it is necessary to add or change the fluid in this transmission use Mopar manual transmission fluid (Mopar part number 4874464 or Texaco 1874). These are the only lubricants recommended for use in the NV-5600 transmission."

This is another example of a lubricant that you will not find at the local auto parts store. We've yet to do a full-blown exposé on the NV5600's lubricant. Discussions with Mike Patton, owner of Standard Transmission and Gear, revealed the following:

The New Venture 5600 gearbox uses a synthetic 30-weight oil. From New Venture literature we know to use the Mopar 4874464 part number. However, Pennzoil Synchronesh, 30-weight, synthetic fluid has been confirmed as an acceptable alternative. The Pennzoil will likely not be easily found, but they've got it in stock at Standard Transmission.

2005-Current Six-Speed G56 Manual Transmission

The lube oil recommended for the G56 transmission is Mopar ATF+4. Mopar ATF+4 is readily available at your local auto parts or Mopar dealership.

AUTOMATIC TRANSMISSION FLUID

For the automatic transmission the latest DaimlerChrysler specification calls for the use of "ATF+4, type 7176."

Unlike the scenario of GL-4 versus GL-5 (in which the former is good but the latter is *not* better), the latest ATF+4 type 7176 can safely be used in all previous 47 RE/RH automatic transmissions. In this case, logic prevails—if +3 is good, then +4 is better! This information was verified by D/C's customer advocate personnel. If you have any doubts about the correct transmission fluid, consult your Owner's Manual.

Briefly the reason Dodge has the +3 and +4 designations is the highly refined base stock and friction modifiers that are specifically designed for the Chrysler transmission.

A footnote to the ATF fluid discussion. Many owners are new to the Dodge product. In order to check the ATF fluid level, the transmission should be at operating temperature and the fluid checked on level ground with the transmission sector in *neutral*. When in neutral the fluid is being routed through the transmission cooler unit. If you check the fluid in *park* the level will show higher than it actually is, as fluid is not being routed to the cooler in the park position. If you make the mistake of checking the fluid level with the vehicle in *Park*, the transmission may be operating without sufficient fluid.

AXLE LUBRICANT

The Owner's Manual suggests that the differential oil be changed every 30-50 thousand miles depending on the load factor. The specification for the axle oil is straightforward: use an API GL-5 rated oil. Use the viscosity that is recommended in your manual.

This replacement fluid is easy to find at the local auto parts store. However, should your '89-'02 truck with a Dana differential be a limited slip model you'll have to add Mopar's Hypoid Gear Oil Additive Friction Modifier to your fluid mixture. Yes, the lubricant is easy to find: the friction modifier is not. For the modifier I do not know of any product other than the recommended Mopar fluid that could (or should) be considered for use. For lack of verifiable information, stay with the factory recommended Mopar friction modifier for your '89-'02 limited slip differential.

In 2003 Dodge changed from Dana to American Axle as the vendor of the front and rear differential units. From my 2003 and 2007 Owner's Manual, "Limited slip rear axles do not require a limited slip additive." The Owner's Manual states fluid changes should be done every 15,000 miles for schedule "B: service."

The Mopar part number for the American Axle lubricant is 5102232AA. The specification from an '07 Owner's Manual calls for "GL-5 SAE 75W90 synthetic lubricant." As always, check your Owner's Manual for specific instructions for changes.

TRANSFER CASE

Wow, here is another easy one. The manual reads, "Use Mopar ATF +4 Automatic Transmission Fluid Type 7176 or equivalent, or a fluid of the type labeled Merco or Dexron III automatic transmission fluid." It is easy to find the Mopar ATF +4, 7176 at the local parts store. For simplicity I would suggest using the ATF +4 in the transfer case too.

ANTIFREEZE/COOLANT

Many owners have heard the truck-stop stories about special additives and conditioners that are necessary in diesel engines. These stories are occasioned by a problem called cavitation erosion (pitting of they cylinder walls due to the implosion of air bubbles in the cooling system) which does occur in many other diesel engines. But the answer is not to be found in a special "brew" for your Turbo Diesel engine. For a complete technical discussion, see Issue 54 and 59. Bottom line: cavitation erosion is not a problem with the Cummins B-series engines in Dodge Ram pickups.

For the definitive answer on coolant, I consulted the 1999 Owner's Manual, "Recommended Engine Coolant."

The manual reads: "Chrysler Corporation vehicles have been designed to operate on ethylene glycol-based engine coolant. Ethylene glycol-based coolants are the only type recommended for use in your Chrysler Corporation vehicle.

"Maintain cooling system solution at a 50% concentration of ethylene glycol antifreeze with water. A higher concentration of antifreeze is recommended if temperatures below -37°F are anticipated, but not to exceed 70% antifreeze. A 50% antifreeze mixture should be maintained year-round for protection against corrosion, boiling, or freezing. If coolant is rusty or dirty, discard and refill as recommended. Do not use additional rust inhibitors or anti-rust products, as they may not be compatible with the radiator coolant."

The preceding passage from the 1999 Owner's Manual material does not give any specifics on the ethylene glycol-based coolants to be used in your Turbo Diesel. Is there newer information in later versions of the Owner's Manual?

Yes, the '03 and '07 manuals are much more specific than the '99 book. Reading from the manual, "Mopar antifreeze/coolant 5year/100.000 mile formula HOAT (hybrid organic additive technology) 5011764AB or equivalent."

Wow, is the HOAT coolant backward compatible with the good 'ole ethylene glycol green stuff that we are all familiar with? Yes, HOAT coolant is backward compatible. Again, TDR Issue 62 and 54 had a lengthy discussion on all of the different types of coolants that are now in the marketplace. Bottom line: stick with the HOAT formulas and you'll be okay.

POWER STEERING

Oops, from the 1999 Owner's Manual here is another vague specification: "Only petroleum fluids specially formulated for minimum effect on rubber hoses should be used. Mopar Power Steering Fluid 04883077 is a fluid of this type and is recommended." Without a clear definition I have defaulted to the Mopar part number. However, the Owner's Manual for a 2003 Turbo Diesel shows the proper fluid to be Mopar ATF+4. Ditto the 2007 manual. So, just as we saw with different manual transmissions, there is not a one-size-fits-all lubricant for truck's power steering. When in doubt check the manual for your truck.

BRAKE FLUID

Yes, another easy item to cross-reference. The manual from my '99 Turbo Diesel reads, "Only brake fluid conforming to DOT-3 and SAE 1703 should be used." DOT-3 fluid is easy to obtain. The 2003 Owner's Manual shows DOT-3, DOT-4 or DOT-4+, the 2007 manual shows the same.

CONCLUSION

No doubt you noticed that there were differences in the specifications from the three Owner's Manuals (1999, 2003, and 2007) that were the basis for this article. Your Owner's Manual is the resource for the specifications. Follow the book's recommendations. Likely you also noticed the evolution of the lube oil specification (from CH to the newly released CJ) and the ATF fluid from Mopar 7176 to 7176 +4. The ATF is backward compatible.

Notes:

MEMORABLE ARTICLES

In Issue 41 we made mention of several surveys that we conducted at the TDR website. As a follow-up I think you'll find the following questions and answers of interest, for we have tried to summarize and add reference listings for this valuable information.

"What is your most memorable article from the TDR?" The responses to this question were refreshing and energizing to all who contribute their articles, whether it be the staff or a member write-in. A couple of examples of comments we received include these: "there are so many memorable articles that my truck would not be where it is now if I had not joined the TDR. [I hope that is a good thing.] "I first read the TDR in the spring of '97. It sold me on the Dodge/Cummins combination and I ordered one of the first '99 models with the six-speed transmission."

Several names appeared frequently in responses to the survey. Is there a risk of giving these guys an inflated ego? I think not, as the writers are all down-to-earth guys that take pride in their work and enjoy teaching what they have learned. Contributions by writers particularly appreciated by the readership include the following: Anything technical by Joe Donnelly; the travel adventures of Bill Swail's EarthRoamer truck (Will the articles have the same interest level now that he has Ford sponsorship? I'm hopeful the answer is yes!); and Kevin Cameron's technical discussions on all things mechanical.

Particularly valuable articles include the following: Third Generation Overview (Issue 36, page 62-28 by writers St. Laurent and Anderson; various articles on the 12-valve engine dowel pin problem and its solutions (Issue 33, page 46; Issue 37, page 16; Issue 38, page 136; and Issue 40, page 56 and 148) by writers Donnelly, Anderson, Timochko and Kilby.

I could continue reporting the positive comments and generalizations, but the purpose of this article is to summarize and mention issue numbers and page references so that you might revisit the article as a learning experience. The following are some of your favorite articles.

Million-mile trucks: Issue 41, page 60; Issue 40, page 90; Issue 33, page 23; Issue 28, page 22.

24-valve lift pump saga: Issue 34, page 47; Issue 36, page 22; Issue 37, page 48; Issue 38, page 46.

24-valve lift pump replacement: Issue 34, page 48.

12-Valve hard start/no start: Issue 41, page 16 and 38; Issue 38, page 42; Issue 36, page 36.

Economical operation of the diesel engine: Issue 29, page 30.

Gauge evaluation: Issue 34, page 20.

Oil Filter evaluation: Issue 32, page 36.

Exhaust brake installation and 12-valve valve spring change out: Issue 36, page 30 and 124.

12-valve valve adjustment: Issue 29, page 44.

First Generation best tips: Issue 39, page 34.

Clutches and drivetrain upgrades: Issue 30, page 36.

Premium diesel fuel and fuel additives: Issue 36, page 24; Issue 30, page 12.

Differential repair: Issue 41, page 150; Issue 24, page 42.

Antifreeze/coolant change: Issue 35, page 76.

Moto-Connoisseurism and the desire for something better: Issue 38, page 68.

Braking systems in plain English: Issue 40, page 96.

Banks' land speed record and Bonneville coverage: Issue 39, page 30.

Trailer towing capacities and payload limits: Issue 35, page 30.

Air + Fuel = Power revisited: Issue 41, page 22.

Fuel quality and the gasoline-in-diesel article: Issue 39, page 138.

Automatic transmission upgrade: Issue 36, page 46.

The options and specifications for all of the different year model trucks: Issue 34, page 74.

NV4500 upgrade for a First Generation truck: Issue 21, page 115.

24-valve fuel pressure specifications: Issue 32, page 38.

24-valve valve adjustment procedure: Issue 30, page 54.

The above list makes me thankful for the many indexes that TDR member Clay Maxam has compiled for us. It made the task of finding "that article about valve-adjustment" easy. My vote for the most memorable TDR articles: Clay's indexes from Issue 41, 37, 33, 29, 25, 21, and 17. Certainly I have found these most useful.

I pulled out my Issue 17 magazine (Clay's index of magazines 1-16) and reminisced. We have covered so many topics! It was interesting to note your favorites, and the listing I made above may prompt many of you to reread an article or two. No doubt that you have more experience since you first read the article and to read it again now will give it new meaning.

Best Tips

“What is the best tip you’ve received from the magazine or website (saved the most money, time, or aggravation)?” As editor it is tempting to cite the following answer given by a respondent, “The whole concept of self help and preventive maintenance that is presented in the magazine and on the website is irreplaceable! I get my \$35 worth every year; all of the magazines are good.” So, there is your answer, “all of the magazines are good and the website is irreplaceable.”

However, I can’t get away without presenting specifics. So, in no particular order, here is a brief list of the best tips that were submitted.

The seat fix for the “sinking feeling:” Issue 35, page 14.

12-valve throttle cable break—a few weeks later mine broke and I was prepared for the problem: Issue 34, page 44.

12-valve return fuel line crack problem: Issue 24, page 19.

NV4500 fifth-gear nut problem: Issue 24, page 26.

24-valve pusher pump installation: Issue 34, page 47.

Fog light relay jumper (keeps fog lights on with high-beams): Issue 23, page 23.

Carry a spare fuel filter, no particular issue, just good common sense.

Changing engine coolant: Issue 35, page 76.

Oil filter disposal in a bag: Issue 26, page 18.

Exhaust manifold retention straps for 24-valve trucks: Issue 38, page 84.

Replacement engine parts from Cummins at a lower price than quoted by my local dealership: various magazines.

First Generation hood cowl repair: Issue 34, page 58; Issue 33, page 41.

First Generation Getrag gearbox lubricant overfill: Issue 38, page 40.

Throttle position sensor repair: Issue 37, page 46.

Installation of a torque converter lockup switch: Issue 23, page 23.

Grid heater dims the lights: Issue 23, page 22.

Cleaning the fuel filter’s pre-screen assembly: Issue 38, page 45; Issue 35, page 85.

Starter rebuild kit: Issue 37, page 151.

Automatic transmission lines and the problems with the plastic fittings (quick connects): Issue 21, page 39.

Understandably survey respondents and the editor had a difficult time differentiating between a self contained tip and an article. I’ve tried to break them out into the appropriate category. Regardless, I’ll reemphasize that the text may prompt a reread and thus additional meaning to you.

An interesting point that I noted is that the favorite article/best tip references were from TDR magazines that were less than two years old which indicates that there is a limit to the shelf-life of the magazine. However, rather than recycle technical data that is past the two-year shelf life, we will try to bring back articles that are still relevant (often appearing in “The Way We Were” column) and update projects and issues as we have more data. This gives another opportunity to reemphasize the value of the TDR indexes that have been published in Issues 41, 37, 33, 29, 25, 21, and 17. Also note the yearly Dodge Technical Service Bulletin summaries that are in this issue of the magazine. The index and the TSB summaries that have appeared in Issue 38, 34, 30, 26, 22 and 18 are great tools to have in your toolbox.

Robert Patton
TDR Staff