

1994-2002 Second Generation Truck

These Install Tips are not a replacement for manufacturer instructions. Read all manufacturer instructions first.

Gauge Wiring:

The cigarette lighter power wires are a good source of "ignition on" power for gauges. You can use these also for the gauge lights, or get a little more creative and take power from the ashtray light, which is on the dimmer circuit. Your choice. In any case, use a multimeter or test light to verify the operation of any wire before using it.

Firewall Pass Through:

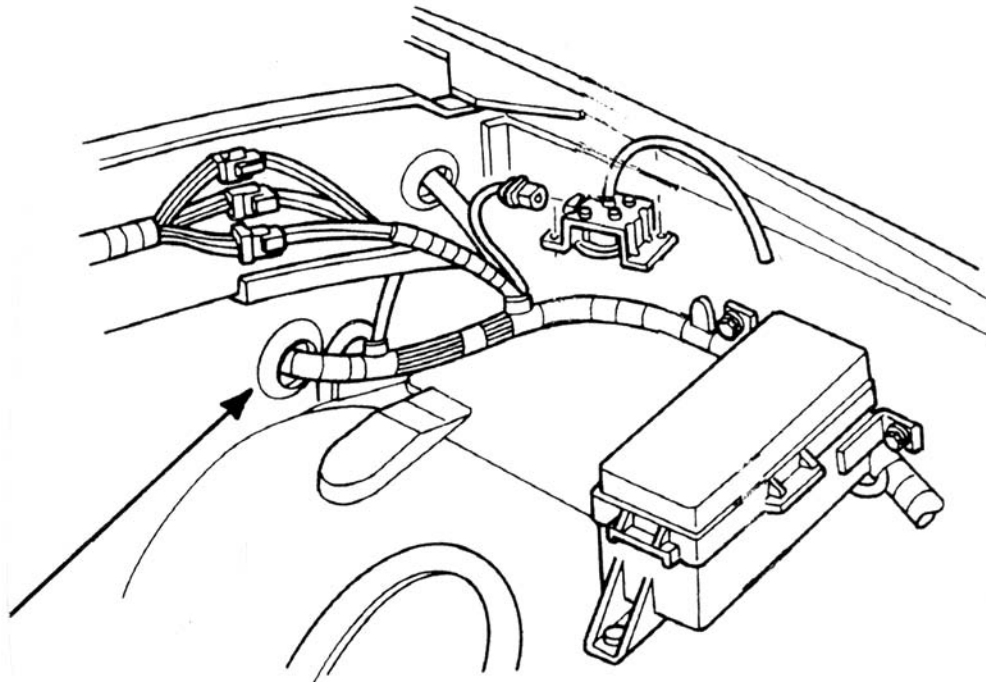

- With flashlight, locate the cluster going through firewall to interior.
- Spray WD40 or similar lubricant on grommet to aid in slipping wires/hose through grommets.
- Push coat hanger through grommet.
- Go back to the interior of the truck. Using needle nose pliers to bend the end of the coat hanger into a hook, place boost hose and pyrometer wires in hook and squeeze.
- Pull hanger through firewall grommet bringing the boost hose and pyrometer wires into engine compartment.

Continued on Next Page ►



If you need more assistance, we are only a phone call away.

(770) 886-2500

Monday-Friday
8:30am-5:30pm EST

GENO'S GARAGE, INC.
1150 Samples Industrial Drive
Cumming, Georgia 30041

Installation: Gauge Install Tips

Pyrometer Installation:

On both the 12-valve and 24-valve engines, the best place to locate the thermocouple in the exhaust manifold is about two inches before the turbo flange gasket surface toward the engine. The manifold has a split-passage design with three cylinders feeding each passage, and a vertical internal web separating the two passages in the center. Thus, the manifold is solid in the center.

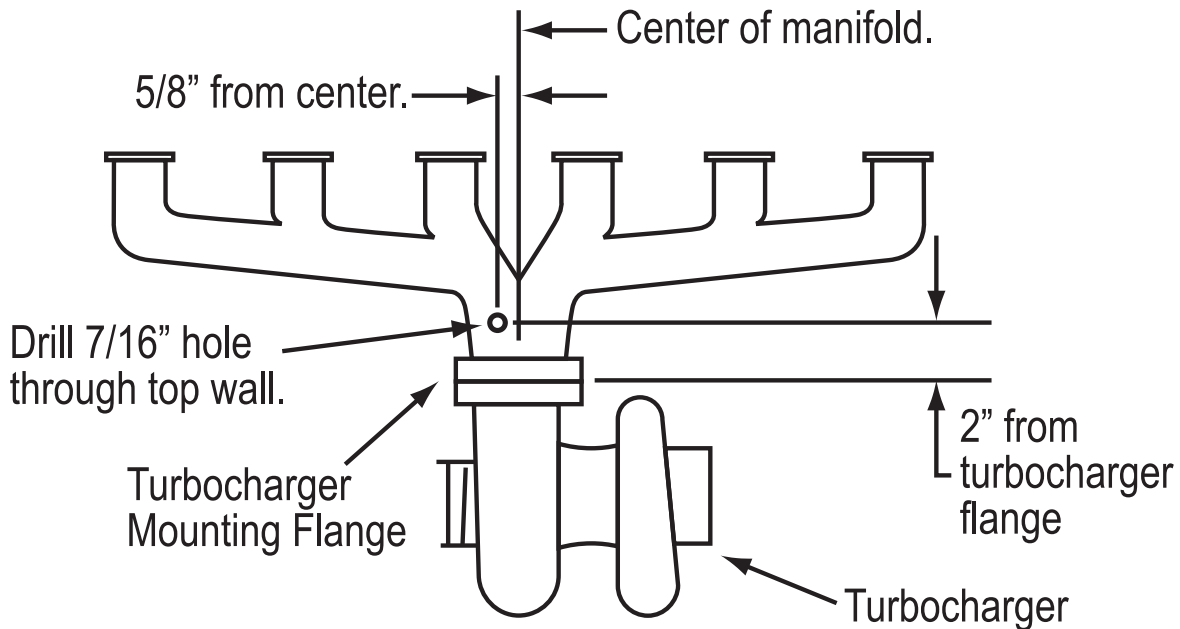

Locate a point two inches from the turbo mounting flange centered on the exhaust manifold, then move forward or rearward on the manifold 5/8," then center punch for drilling. If you are using a 1/4 NPT probe, drill a 7/16" diameter hole straight down through one wall. If you have a 1/8 NPT probe, drill a 5/16" diameter hole. Putting axle grease on the drill and tap will help prevent shavings from falling into the manifold. Tap threads using 1/4 NPT pipe tap or the 1/8 NPT pipe tap.

Use a small mechanic's magnet that will pass through the tapped hole to the bottom wall of the manifold to retrieve drill and tap shavings. Clean shavings from magnet, then search for more shavings. Repeat until the magnet comes back clean. Don't worry, the balance of any metal shavings will blow past the turbo exhaust wheel at initial start up and should not be a concern.

We suggest locating the probe prior to the turbocharger in the exhaust manifold as described above. The manifold readings are very quick. Since the turbocharger uses heat energy, exhaust readings after the turbocharger in the exhaust system are slower to reach their maximum number.

Alternatively, if you have an exhaust brake (specifically, Pacbrake or BD brake), the brake housing/elbow is already drilled, tapped and plugged at 1/4 NPT. Remove the plug, and simply install the 1/4 NPT EGT sensor.

Upon assembly in either location, the sensor should be half-in/half-out of the mounting/compression fitting.

Installation: Gauge Install Tips

Boost Connection:

'94-'98, 12-Valve Trucks

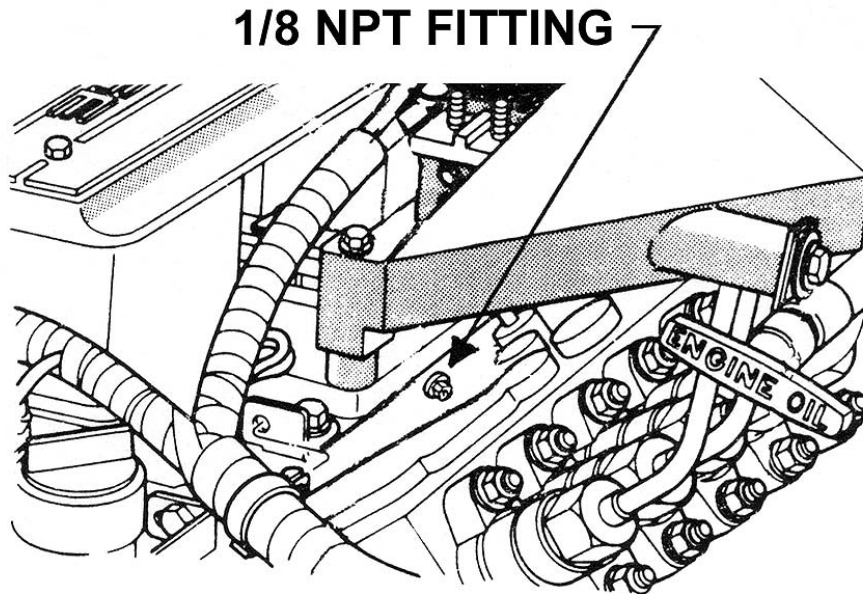

- Route rubber hose to boost tap location on engine intake manifold.
- Locate and remove the 1/8 NPT fitting from intake manifold.
- Install boost fitting to intake manifold.
- Install rubber hose to fitting. Use tie wrap to secure hose to fitting.

'98-'02, 24-Valve Trucks

Using the “boost bolt,” we picked a location close to the firewall to install the boost bolt. Any of the inner row (closest to valve cover) will do. On the gauge side, if the line is rubber instead of plastic with compression fittings, use a small tie wrap to ensure that the boost line does not pop off of the gauge.

Transmission Temperature

(Please see supplemental instructions if you purchased the Westach temp gauge with dipstick sending unit.)

We highly recommend installing the temperature sending unit directly in the transmission drain pan. This provides consistent readings and gives a good idea of overall temperature of the fluid.

Install the sending unit in any flat side of the pan. The right (passenger's side) side has a small flat section near the middle that will not interfere with the fluid pickup and will not block the bolts that fasten the pan in place. If you opted for the B&M drain plug to assist in mounting, drop the pan, drain, and drill the 1/2" hole in the side of the pan and install the plug.

A no-leak tip: use epoxy (JB Weld) around the internal edges of the plug to prevent fluid leakage. Install the 1/8 NPT sensor with Teflon tape.

Continued on Next Page ►

Installation: Gauge Install Tips

Gauge Testing/Tips

Boost – Be advised that upon initial start up, you will not register a boost “number.” It takes engine load to make exhaust flow; thus intake boost pressure. Take the truck for a test drive. You will find the boost pressure will parallel the position of your accelerator pedal.

Typical 60 mph, half-throttle boost number is 8 – 10 psi. Rule of thumb: every psi of boost equals 10 horsepower (i.e. 10 psi means you're using 100 horsepower to motor down the road).

Full throttle equals full boost. '94 – '97 trucks have a maximum boost specification of 15 – 18 psi.

The 215 hp, '96 – '98 trucks have a maximum boost specification of 21 – 23 psi. The '98 – '02, 24-valve engines have a maximum boost specification of 20 psi.

Pyrometer – as a guideline, do not exceed 1000° – 1050°F with the pyrometer in a post turbo location such as the exhaust elbow or exhaust brake elbow. If you installed the pyrometer pre-turbo, in the exhaust manifold, do not exceed 1250° – 1300°F.

You will find the EGTs will parallel the position of your accelerator pedal. A typical 60 mph, half-throttle EGT number is 600° – 700°F (probe location prior to the turbocharger). Readings are usually lower if the probe is located after the turbocharger.

Be advised that the registered temperature reading will only be 250° – 350°F (ambient air temperature and location of the sensor are the reasons for the variance) at initial start-up and idle. It takes engine load to make the EGT escalate.

Transmission Temperature – The lower you can keep the temperature, the longer your transmission is likely to last. The oil viscosity starts to break down around 220°F, and the transmission will be much happier below this point. Maximum oil temperature in the pan should not exceed 250°F. If the temperature rises above this point, pull over and fast idle the engine in neutral for a few minutes to cool the transmission fluid.